

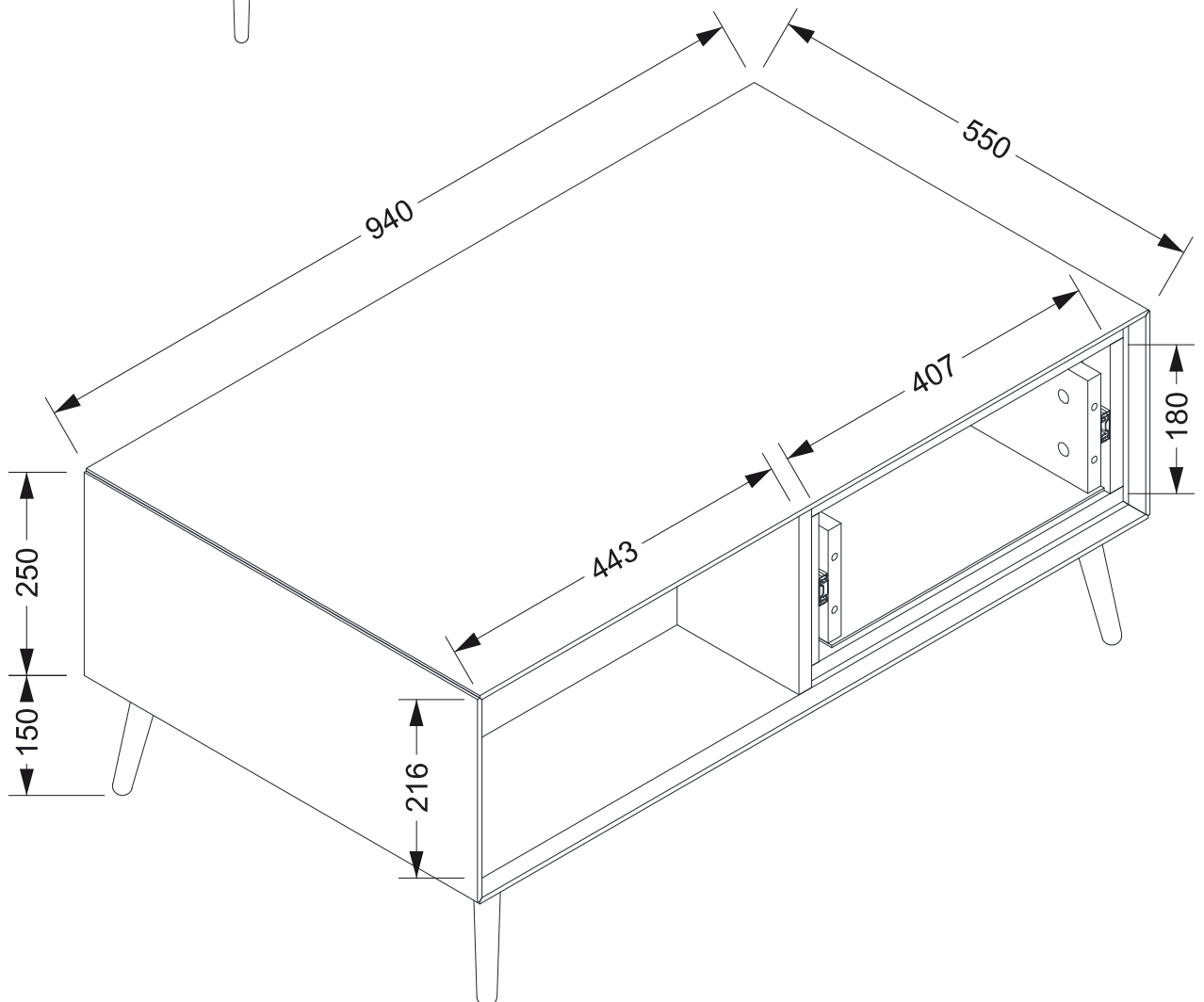

ARN 55A/180

finori GmbH
Straßäcker 2
D - 96253 Untersiemau

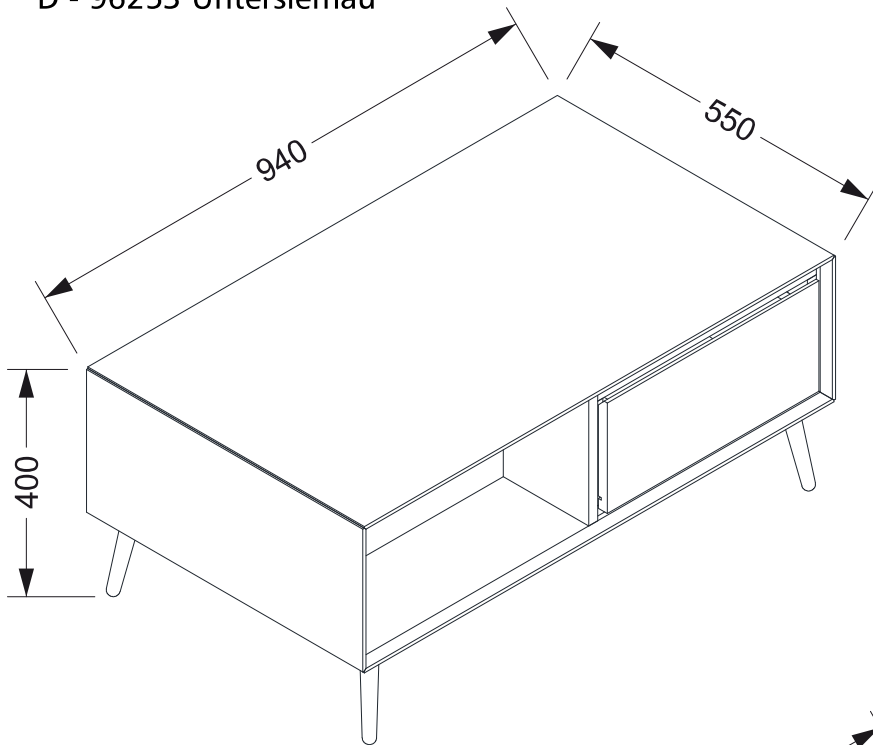



- Ⓓ Befolgen Sie stets die Anleitung des Herstellers!
- Ⓒ Please generally follow the manufacturer's instructions!
- Ⓕ Suivez toujours les instructions du fabricant!
- Ⓓ Volg steeds de handleiding van de producent!
- Ⓔ Siga siempre las instrucciones del fabricante!
- Ⓗ Stale przestrzegaj instrukcji producenta!

- Ⓓ Всегда следуйте инструкции производителя!
- Ⓓ Seguire sempre le istruzioni del produttore!
- Ⓓ Mindig tartsa be a gyártó utasításait!
- Ⓓ Siga sempre as instruções do fabricante!
- Ⓓ Vždy dodržujte pokyny výrobce!
- Ⓓ Vždy dodržujte pokyny výrobcu!



- Ⓓ Verwenden Sie zur Reinigung nur ein feuchtes Tuch!
- Ⓒ Please only clean with a damp cloth!
- Ⓕ N'utilisez qu'un chiffon humide pour le nettoyage!
- Ⓓ Gebruik voor de reiniging enkel een vochtige doek!
- Ⓔ Para limpiar utilice sólo un paño húmedo!
- Ⓗ Do czyszczenia używaj wilgotnej szmatki!

- Ⓓ Для очистки используйте только влажную ткань!
- Ⓓ Per la pulizia, utilizzare solo un panno umido!
- Ⓓ A tisztításhoz elegendő egy nedves kendő használatát!
- Ⓓ Para a limpeza use apenas um pano húmido!
- Ⓓ Pro čištění používejte pouze vlhký hadřík!
- Ⓓ Na čistenie používajte iba vlhkú handričku!

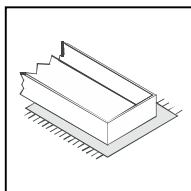

- Ⓓ Bauen Sie das Produkt auf einer Unterlage auf!
- Ⓒ Please mount the product on a bottom support!
- Ⓕ Montez le produit sur une base!
- Ⓓ Monteer het product op een basis!
- Ⓔ Monte el producto sobre una base!
- Ⓗ Rozkładaj produkt na podkładce!

- Ⓓ Собирайте изделие на подстилке!
- Ⓓ Montare il prodotto su un supporto!
- Ⓓ Az összeszereléskor helyezzen a termék alá megfelelő alátétet!
- Ⓓ Monte o produto numa superfície plana!
- Ⓓ Výrobek smontujte na pevném podkladu!
- Ⓓ Výrobok zmontujte na pevnom podklade!

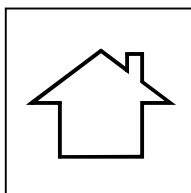

- Ⓓ Verwenden Sie das Produkt nur in Innenräumen!
- Ⓒ Please exclusively use the product indoors!
- Ⓕ N'utilisez le produit qu'à l'intérieur!
- Ⓓ Gebruik het product enkel binnenshuis!
- Ⓔ Utilice el producto sólo en interiores!
- Ⓗ Używaj produkt tylko w pomieszczeniach wewnętrznych!

- Ⓓ Используйте изделие только во внутренних помещениях!
- Ⓓ Utilizzare il prodotto solo in ambienti interni!
- Ⓓ A termék csak bel terekben használható!
- Ⓓ Use o produto apenas no interior!
- Ⓓ Používejte výrobek pouze uvnitř!
- Ⓓ Výrobok používajte len vo vnútri!

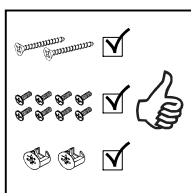

- Ⓓ Legen Sie die Beschläge zusammen und prüfen Sie die Vollständigkeit!
- Ⓒ Please join the fittings and verify their completeness!
- Ⓕ Pliez les raccords ensemble et vérifiez qu'ils sont complets!
- Ⓓ Leg de onderdelen samen en controleer de volledigheid!
- Ⓔ Junte los accesorios y compruebe que están todos!
- Ⓗ Rozłóż poszczególne części i sprawdź kompletność!

- Ⓓ Положите фурнитуру в одно место и проверьте комплектность!
- Ⓓ Mettere insieme le garnizioni e verificarne la completezza!
- Ⓓ Állítsa össze a sarokvasakat, és ellenőrizze, hogy épek-e!
- Ⓓ Coloque os encaixes juntos e verifique se estão completos!
- Ⓓ Složte armatury a zkontrolujte úplnost!
- Ⓓ Zložte armatúry a skontrolujte úplnosť!

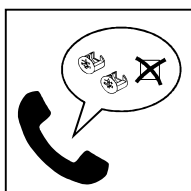

- Ⓓ Bei fehlenden Teilen kontaktieren Sie den Hersteller!
- Ⓒ If parts are missing, please turn to the manufacturer!
- Ⓕ En cas de pièces manquantes, veuillez contacter le fabricant!
- Ⓓ Contacteer de fabrikant als er onderdelen ontbreken!
- Ⓔ En el caso de que falten piezas, póngase en contacto con el fabricante!
- Ⓗ W razie braku części skontaktuj się z producentem!

- Ⓓ При отсутствии каких-либо частей обратитесь к производителю!
- Ⓓ In caso di pezzi mancanti, contattare il produttore!
- Ⓓ Ha hiányozna valamelyik elem, lépjen kapcsolatba a gyártóval!
- Ⓓ Em caso de peças em falta, entre em contato com o fabricante!
- Ⓓ Pro chybějící díly kontaktujte výrobce!
- Ⓓ Ak vám chýbajú diely kontaktujte výrobcu!

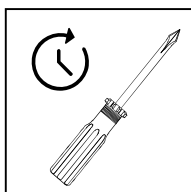

- Ⓓ Ziehen Sie die Schrauben nach einiger Zeit des Gebrauchs erneut fest!
- Ⓒ Please re-tighten the screws after having used the product for a while!
- Ⓕ Resserrer les vis après un certain temps d'utilisation!
- Ⓓ Draai de schroeven na een zekere gebruikstijd opnieuw vast!
- Ⓔ Asegure de nuevo los tornillos tras usarlo durante un tiempo!
- Ⓗ Po pewnym czasie użytkowania ponownie dokręć śruby!

- Ⓓ Спустя некоторое время использования подкрутите гайки!
- Ⓓ Stringere nuovamente le viti dopo un certo periodo di utilizzo!
- Ⓓ A használat során némi idő elteltével húzza meg újra a csavarokat!
- Ⓓ Reaperte os parafusos após algum tempo de uso!
- Ⓓ Po určité době používání šrouby znovu utáhněte!
- Ⓓ Po určitej dobe používania skrutky znovu utiahnite!

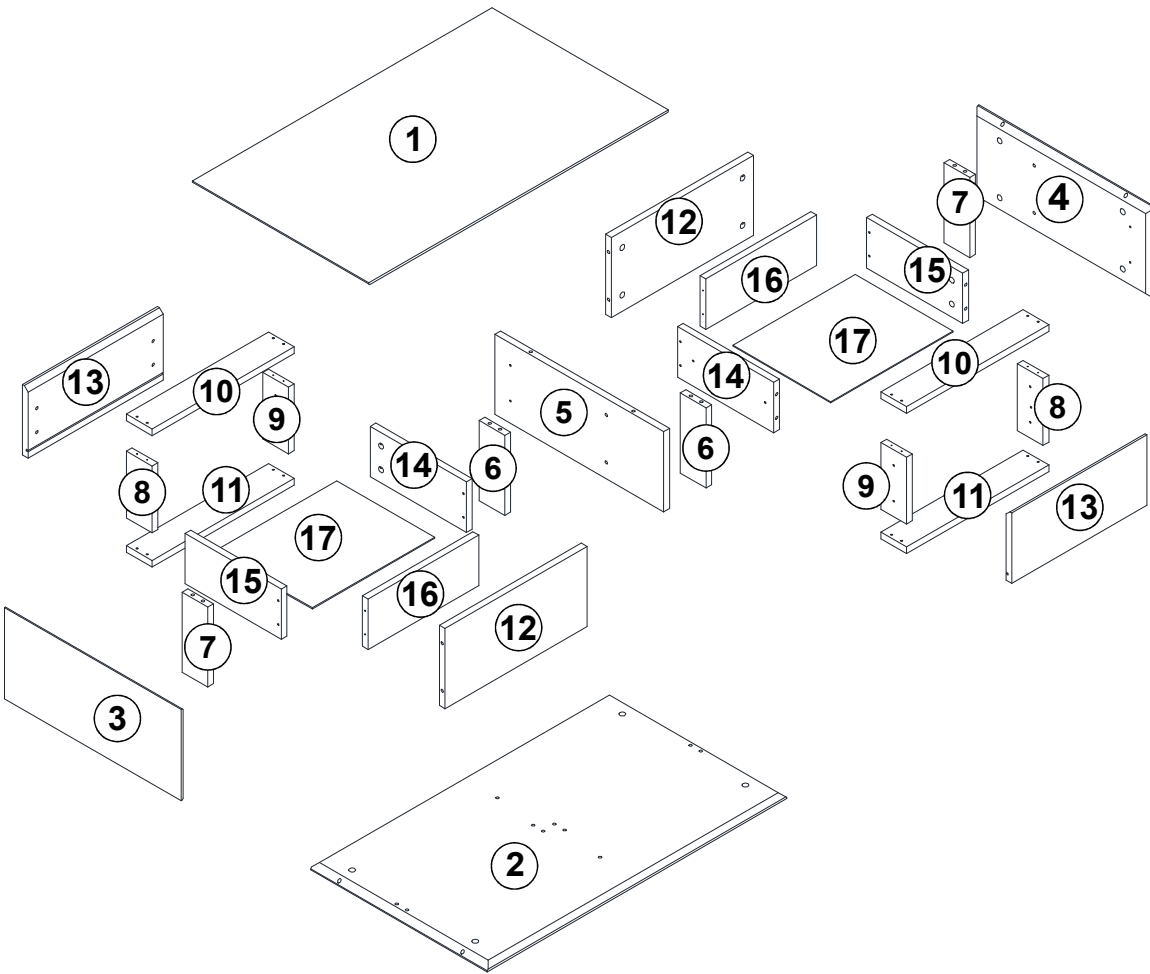
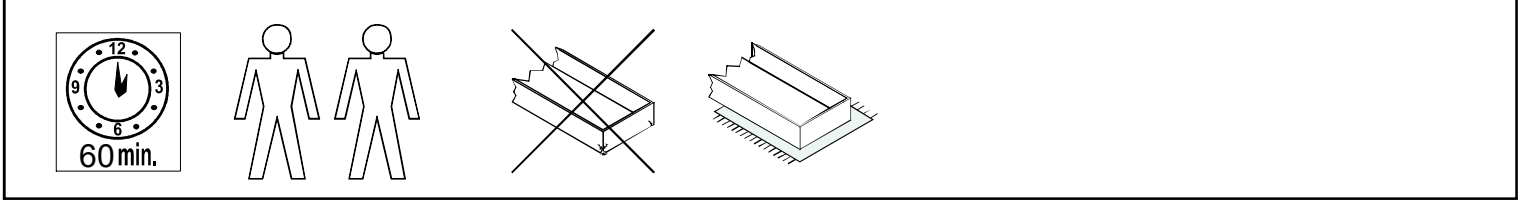

.01	1	934	550	18
.02	1	934	550	18
.03	1	246	550	18
.04	1	246	550	18
.05	1	526	216	18
.06	2	216	80	18
.07	2	216	80	18
.08	2	171	80	18
.09	2	171	80	18
.10	2	443	80	25
.11	2	443	80	18
.12	2	441	216	18
.13	2	421	190	18
.14	2	300	136	18
.15	2	300	136	18
.16	2	345	136	18
.17	2	381	305	3

BOX 1	1,2,3,4,5,6,6,7,7,8,8,9,9,10,10,11,11,12,12,13,13,14,14,15,15,16,16,17,17
--------------	---



BOX 1 

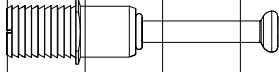

A23x32



A04x4

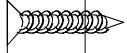

A18x32

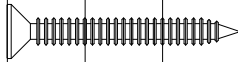

A41x8

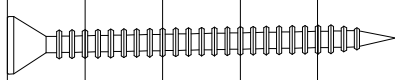

A17x24

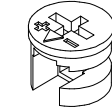

A22x48

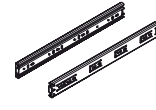

P02x2T
33x300

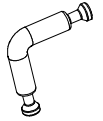

K48x8
8x36



KUMTAŞI
18mm



A48x14

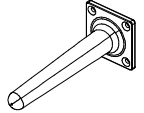



H54x4
SYH
15CM

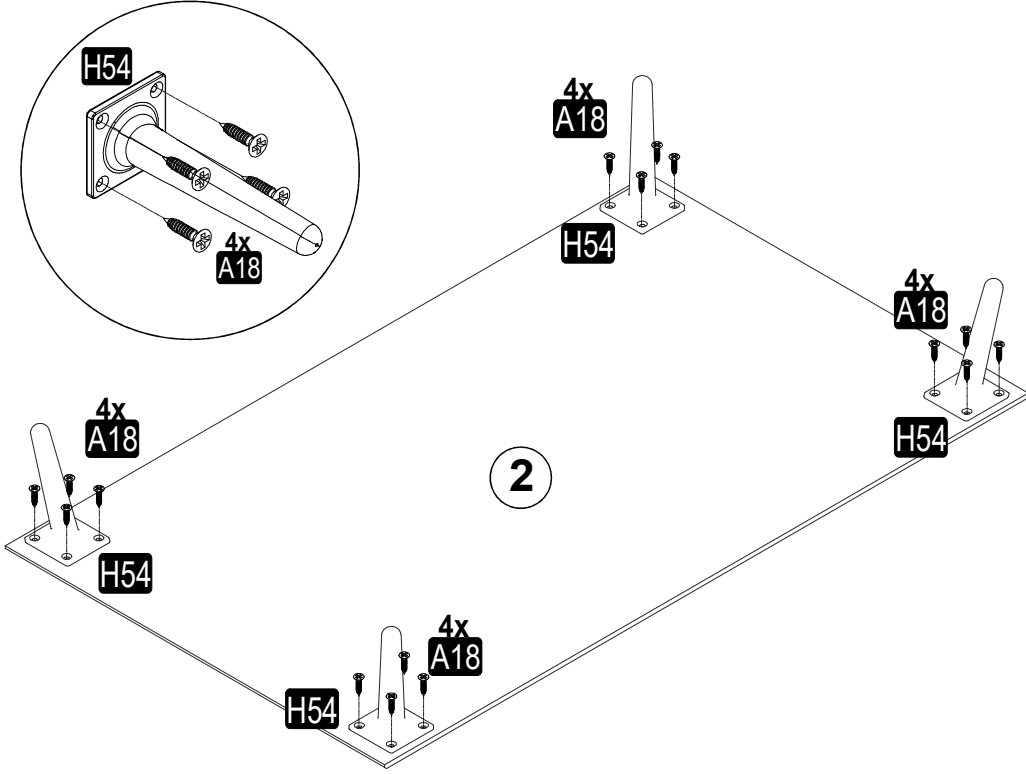

A10x8
KUMTAŞI
14 mm

1



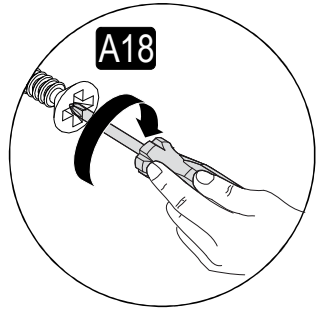

A18	YHB VD
	16x
3,5x18	
H54	BONE PLSTK AYK
	4x
SYH 15cm	

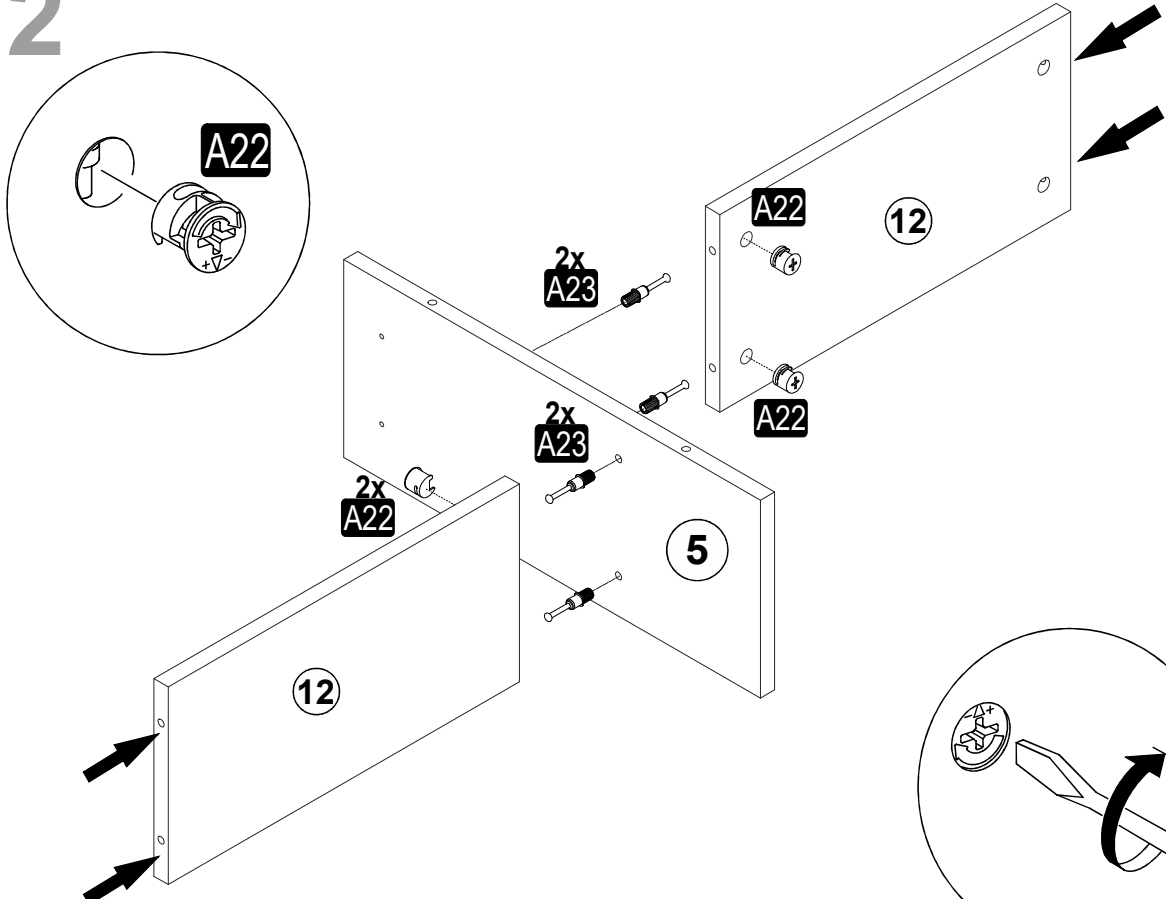

2

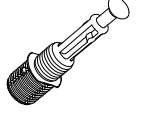

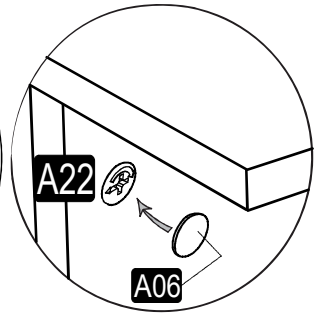
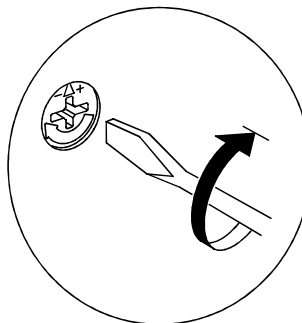

A22	Minifix G18
	4x
15x14	
A23	Minifix M8
	4x
8x34	
A06	TAPA
	4x
KUMTAŞI 18 mm	

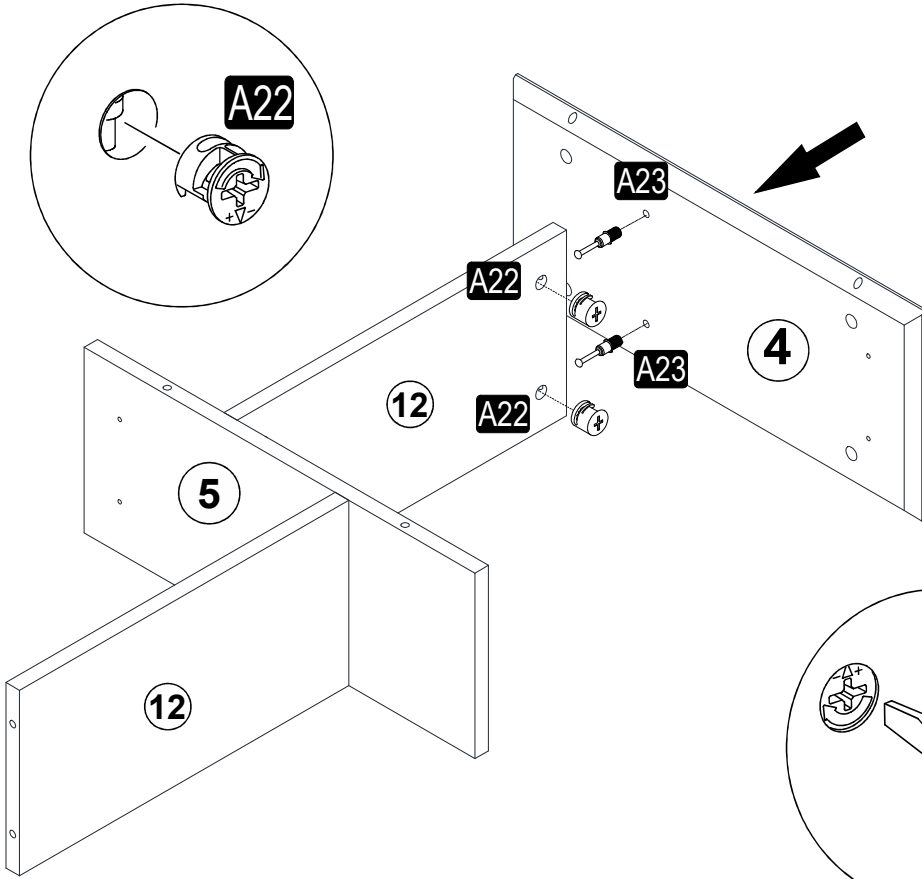

3

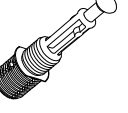

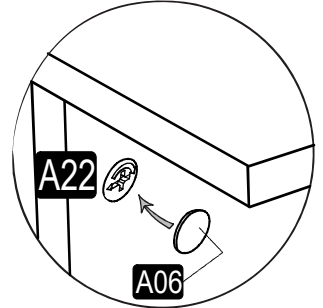
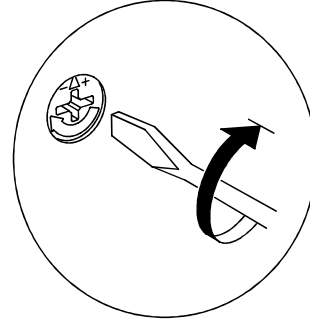

A22	Minifix G18	
15x14		2x
A23	Minifix M8	
8x34		2x
A06	TAPA	
KUMTAŞI 18 mm		2x

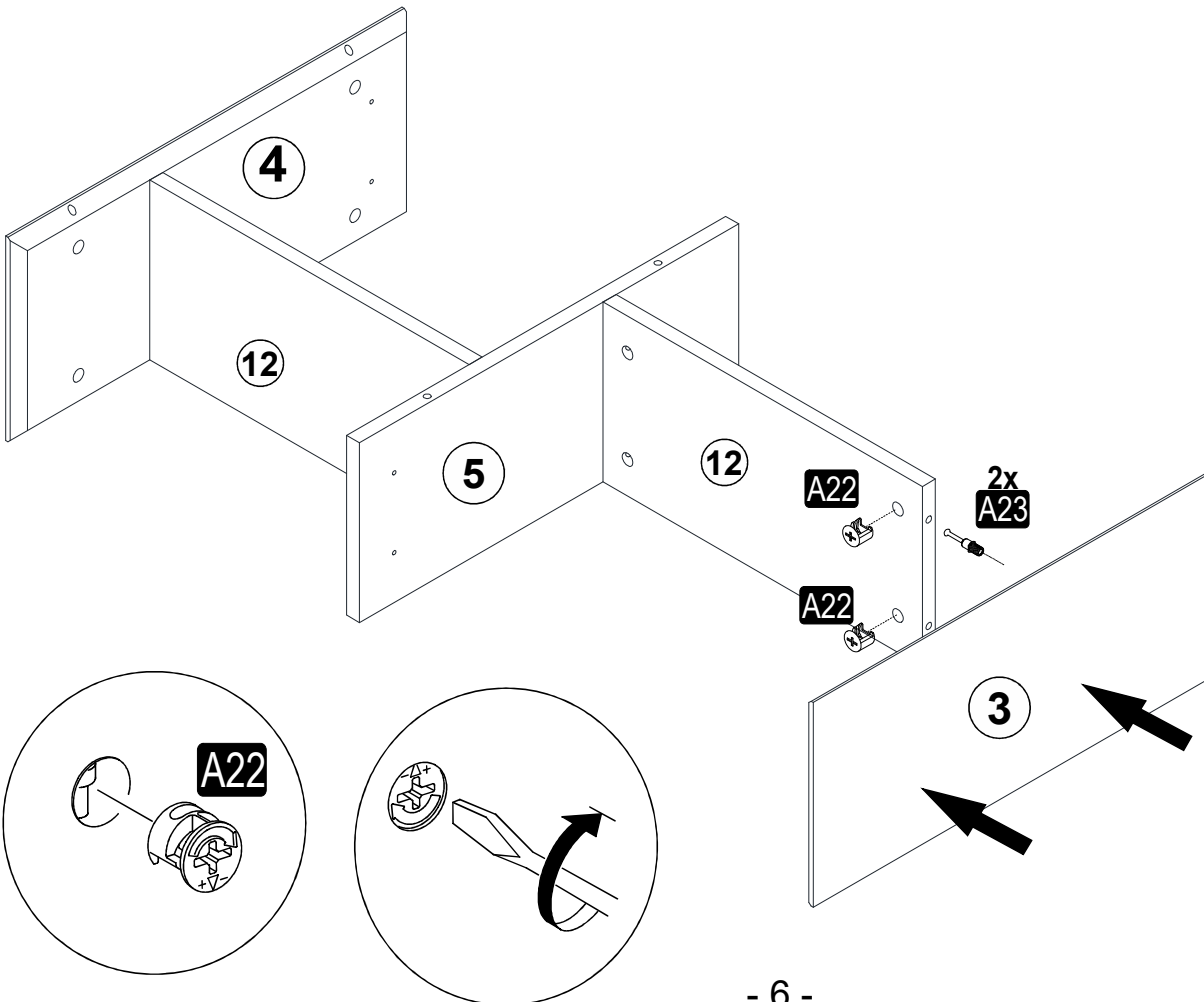

4

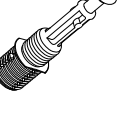

A22	Minifix G18	
15x14		2x
A23	Minifix M8	
8x34		2x
A06	TAPA	
KUMTAŞI 18 mm		2x

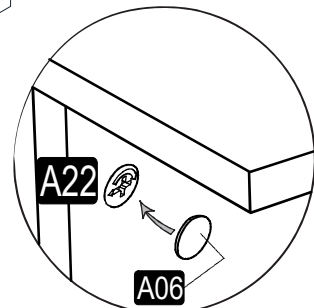
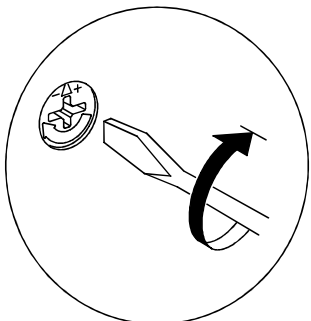
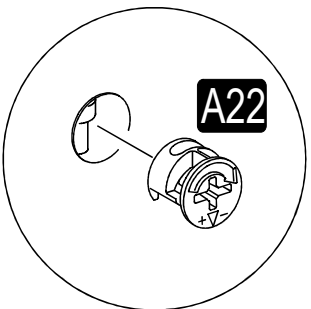

5

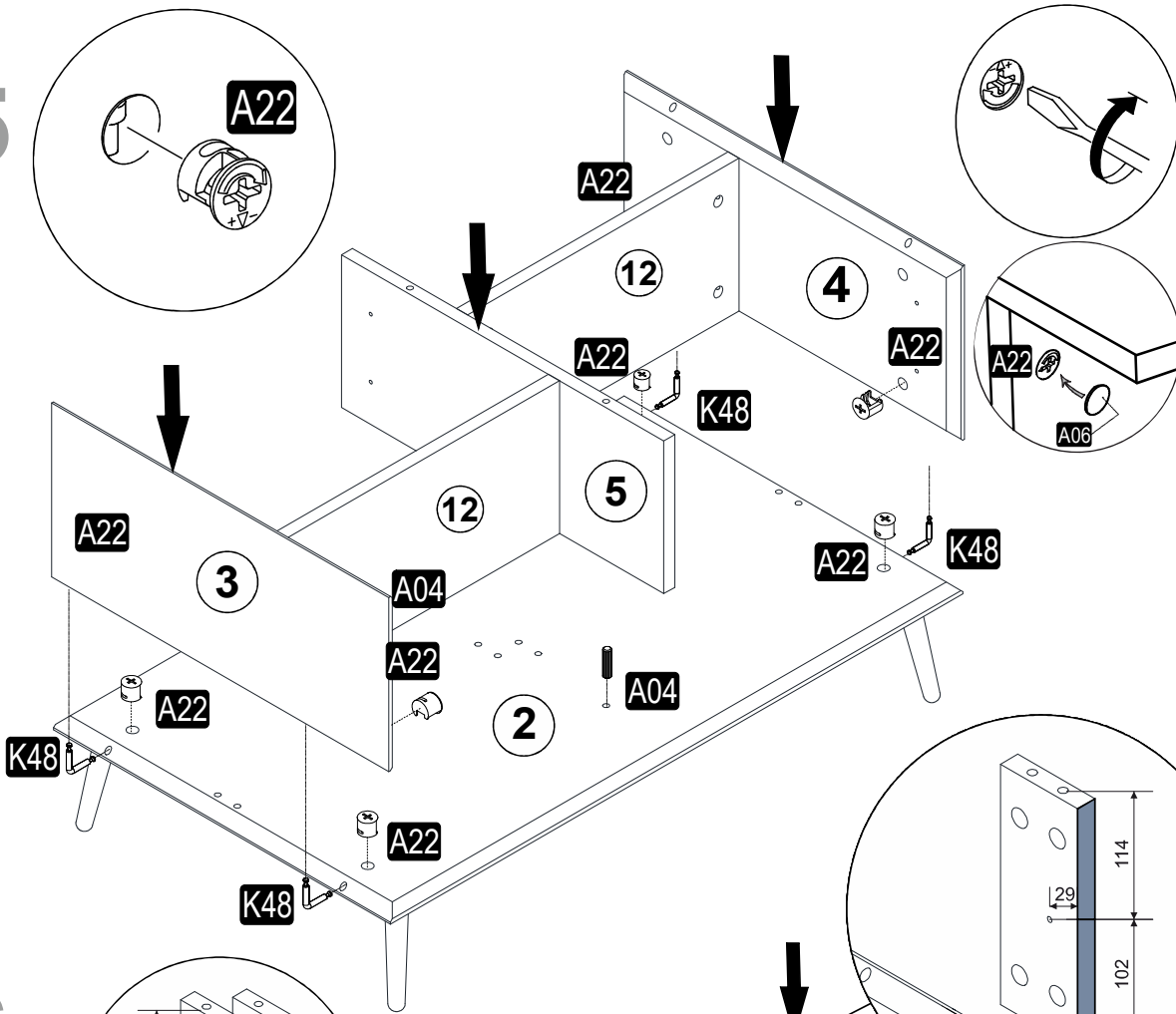

K48	Minifix Mil 90	8x36	4x
A22	Minifix G18	15x14	8x
A06	TAPA	KUMTAŞI 18 mm	8x
A04	PLSTK KVLY	8x30	2x

6

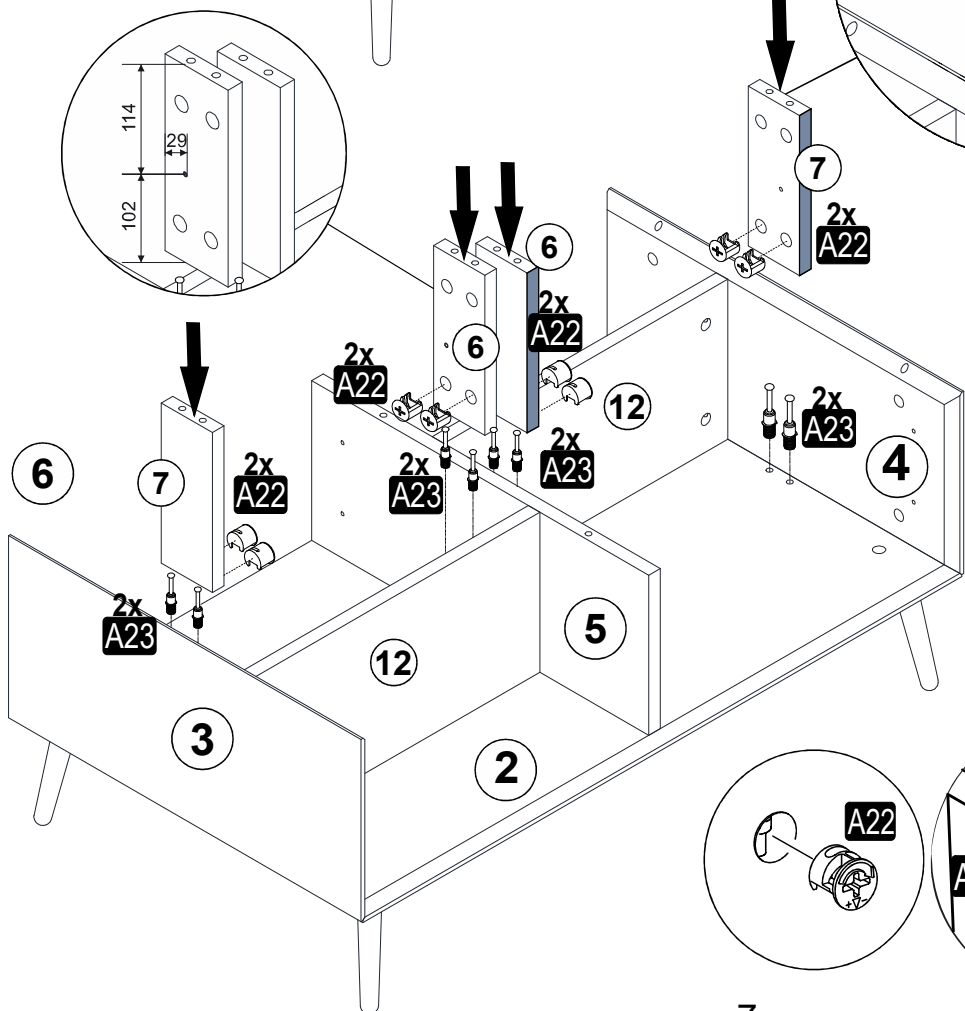

A23	Minifix M8	8x34	8x
A06	TAPA	KUMTAŞI 18 mm	8x
A22	Minifix G18	15x14	8x

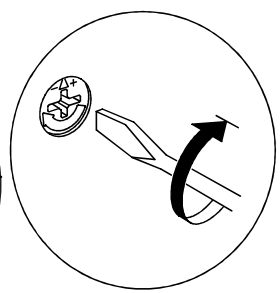
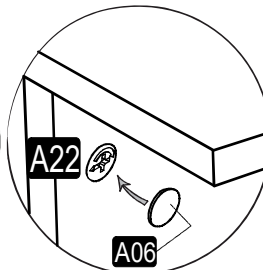
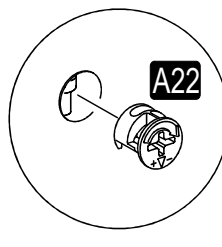

7

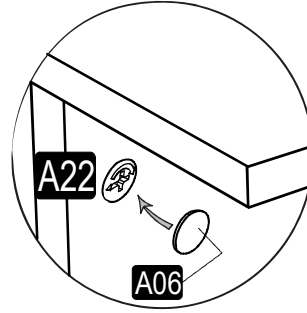
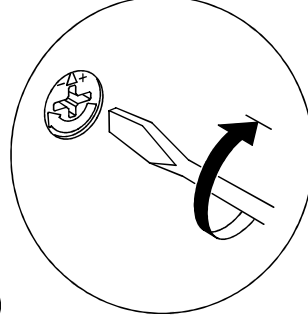
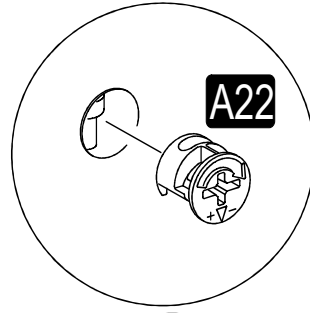
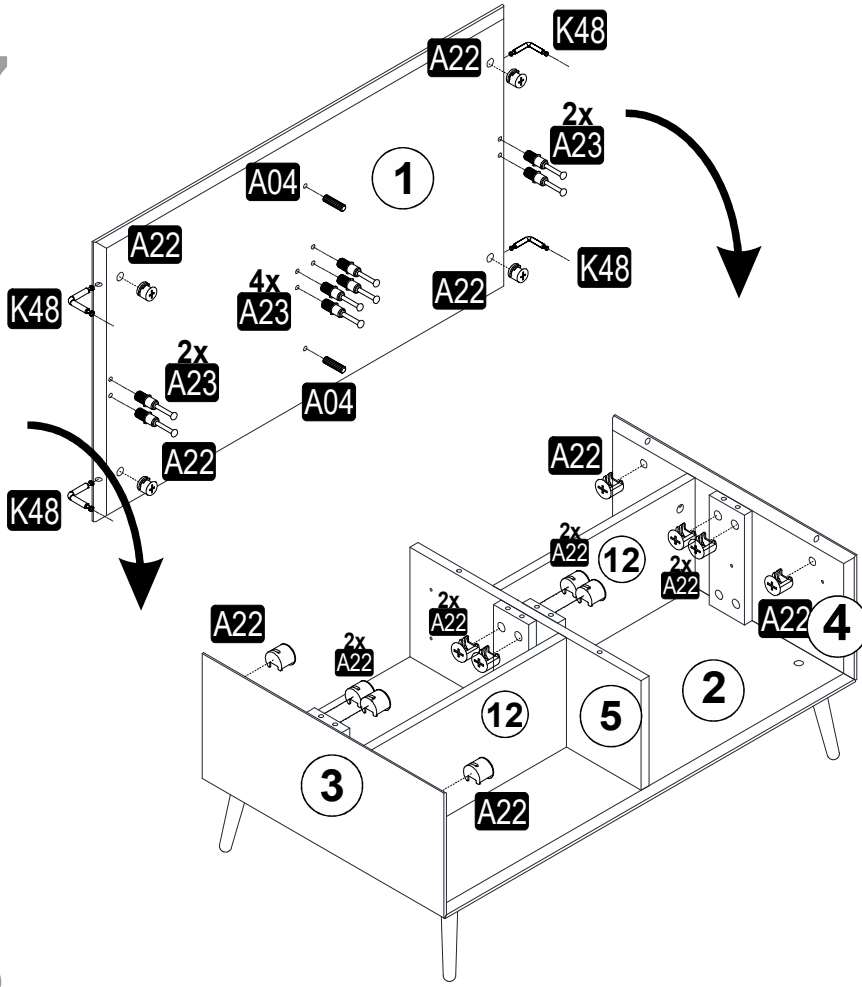

A22	Minifix G18	15x14	16x
A04	PLSTK KVLVY	8x30	2x
K48	Minifix Mil 90	8x34	4x
A06	TAPA	KUMTAŞI 18 mm	16x
A23	Minifix M8	8x34	8x

8

2x

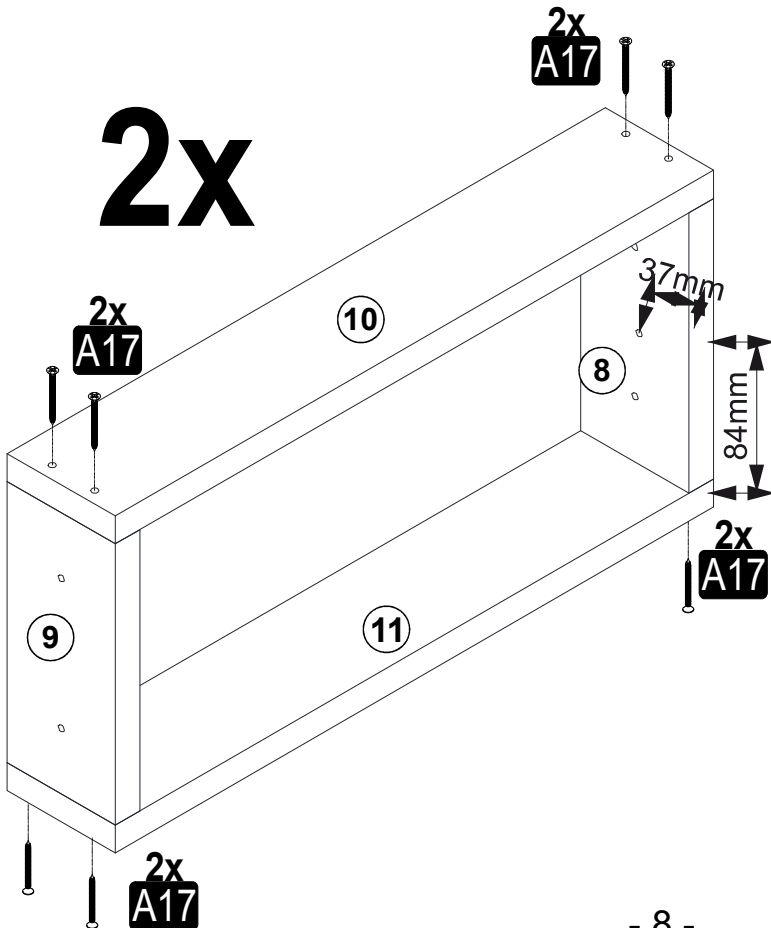

A17	YHB VD	4x50	16x
------------	--------	------	-----

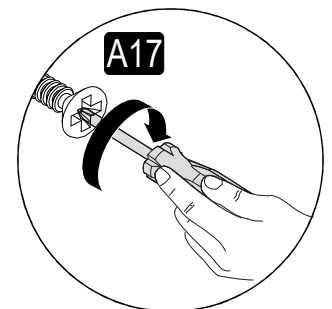

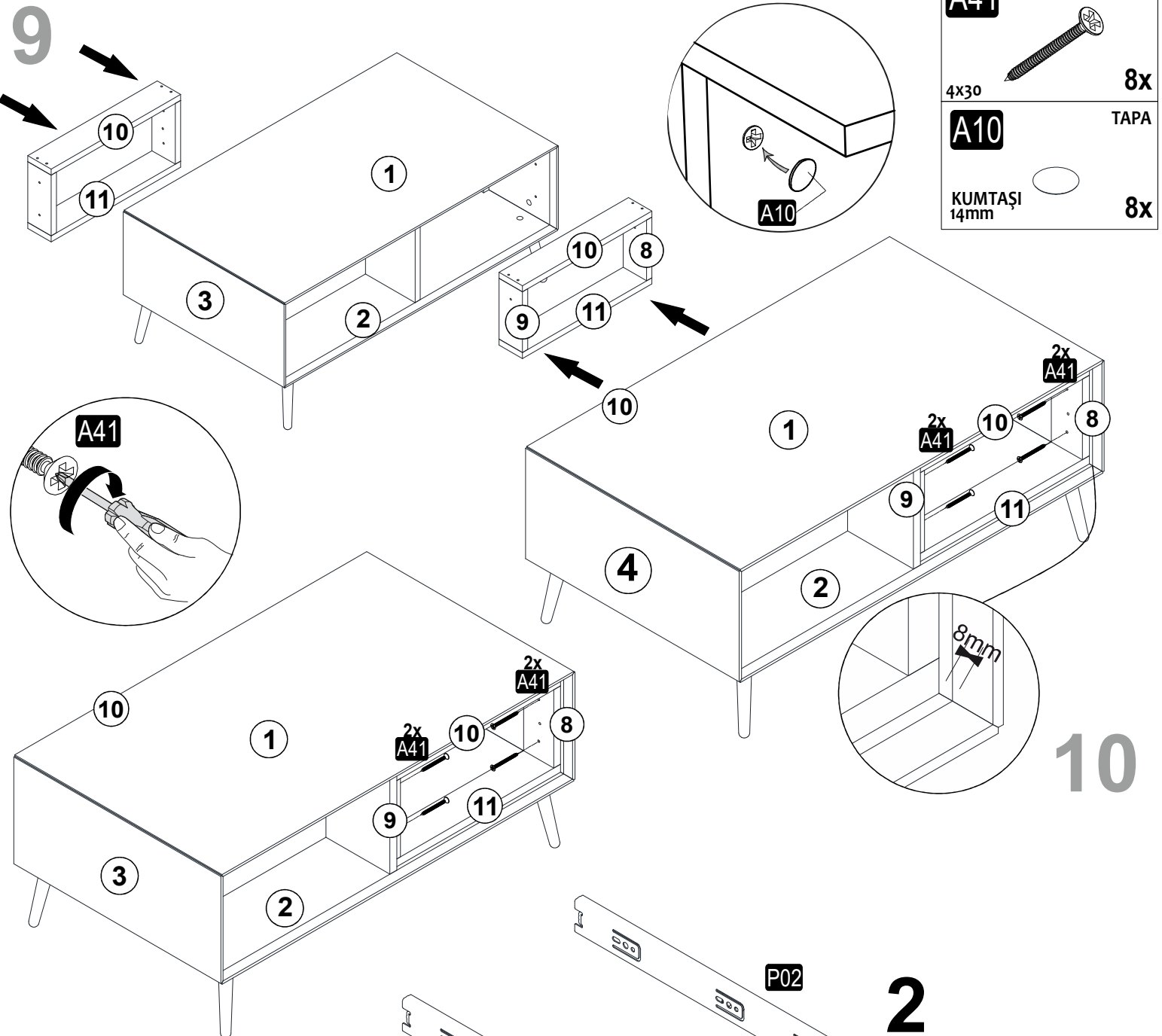

A41	YHB VD
4x30	8X
A10	TAPA
KUMTAŞI 14mm	8X

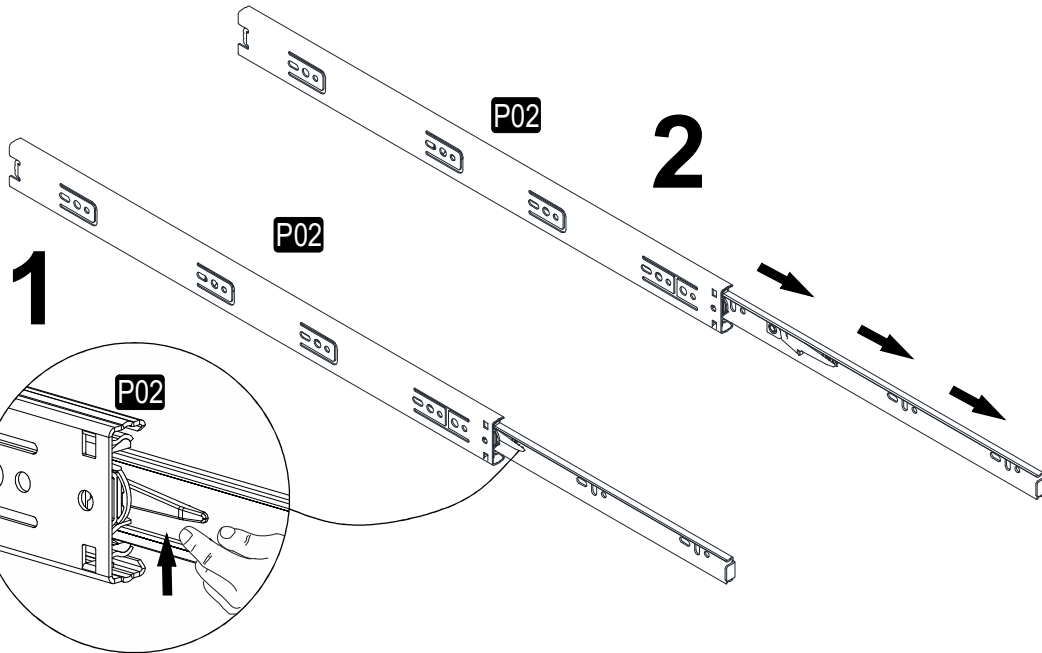
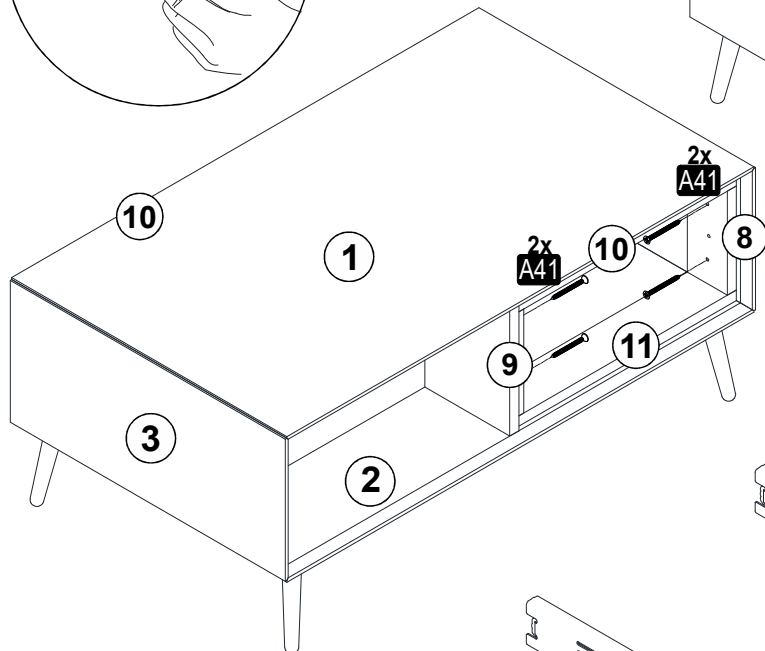
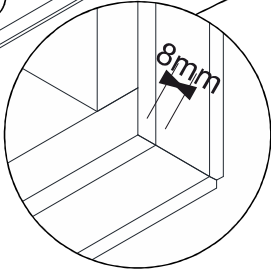
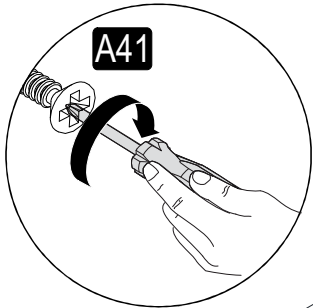

P02	TLSKPK RAY
33X300	2T

11

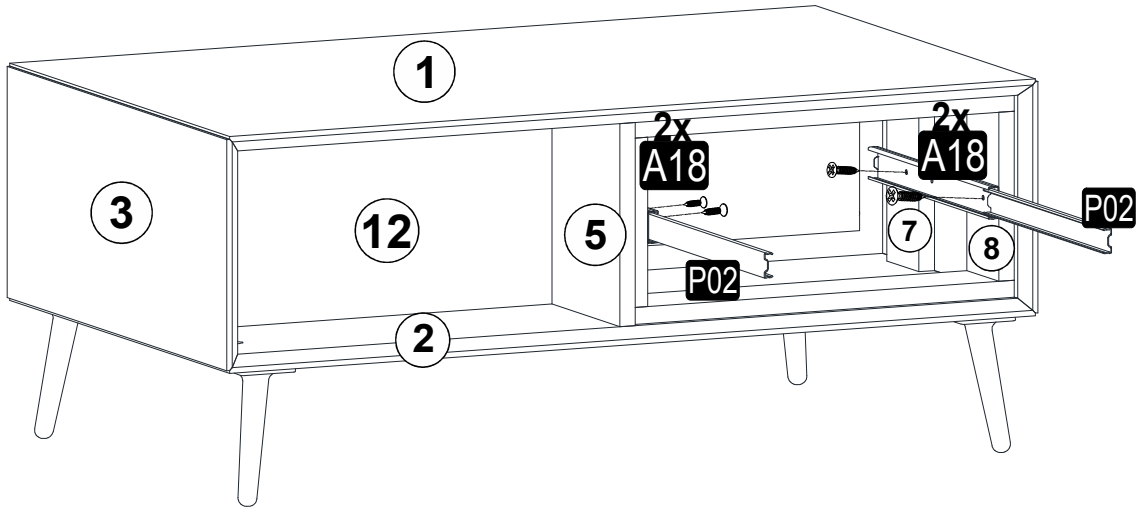

P02	TLSPKP RAY
	1T
33x300	
A18	YHB VD
	4x
3,5x18	

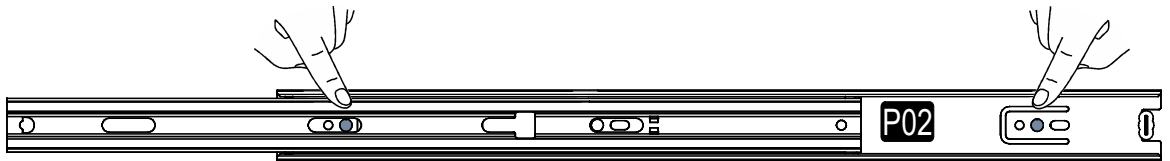
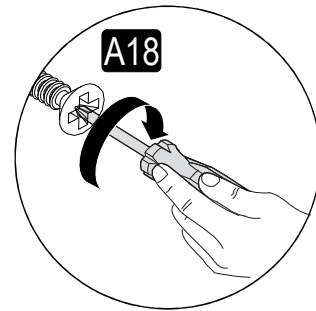

12

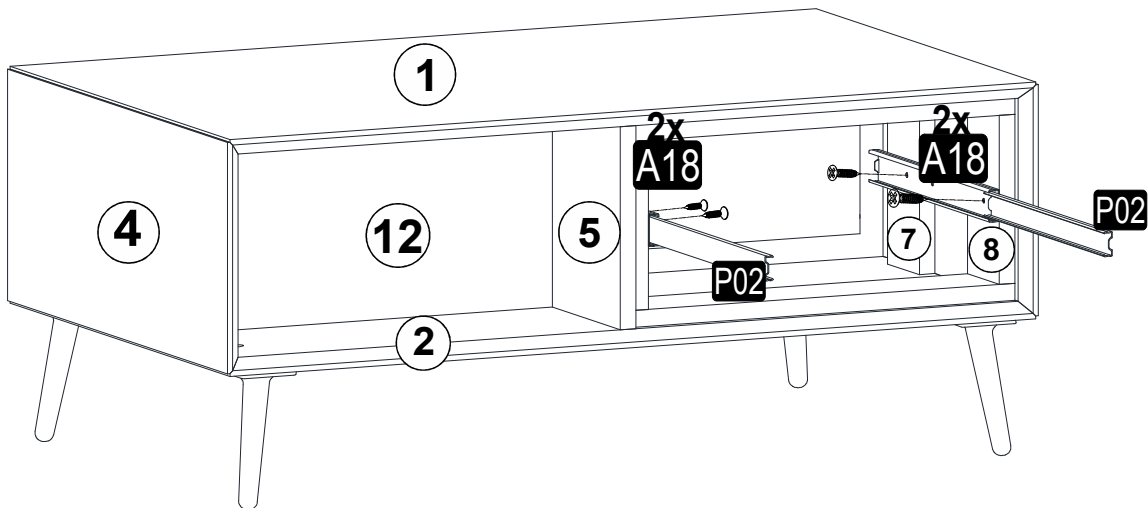

P02	TLSPKP RAY
	1T
33x300	
A18	YHB VD
	4x
3,5x18	

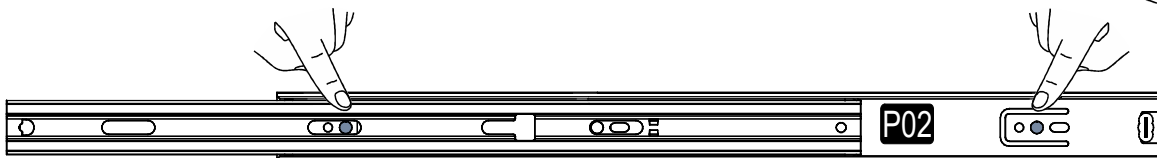
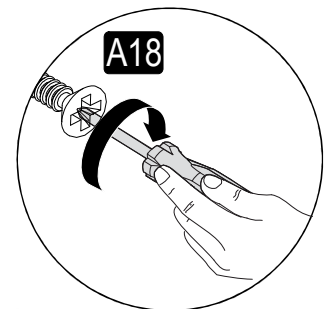

13

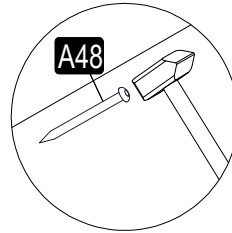
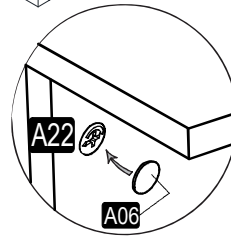
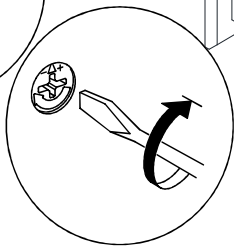
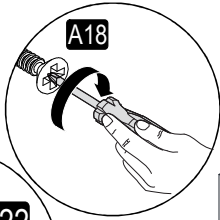
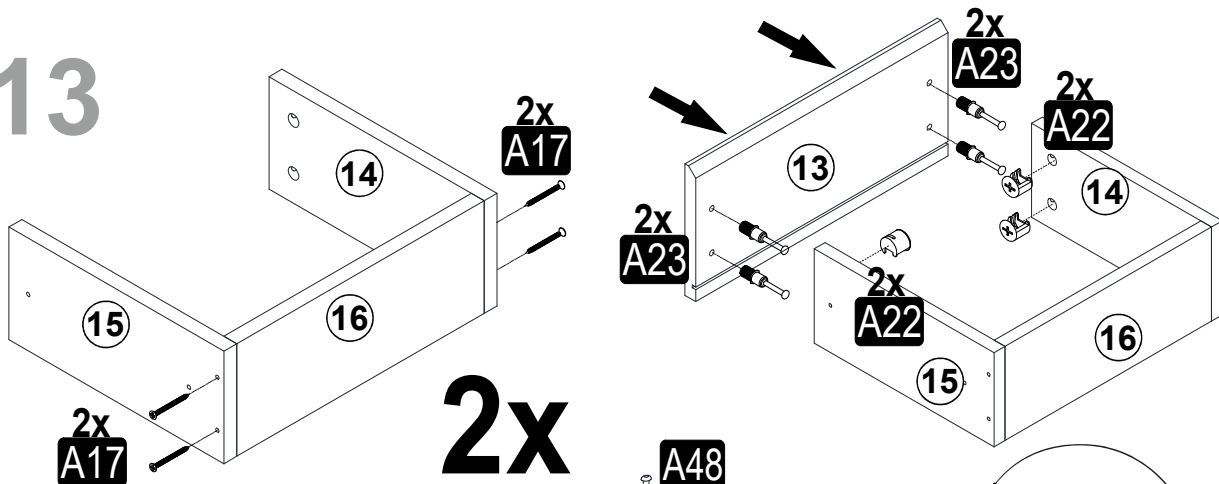

A17	YHB VD	8x
4x50		
A22	Minifix G18	8x
15x14		
A23	Minifix M8	8x
8x34		
A48	ARKLK CVS	14x
A06	TAPA	8x
KUMTAŞI 18 mm		

14

2x

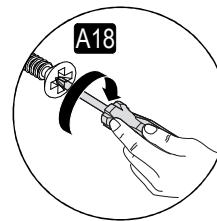
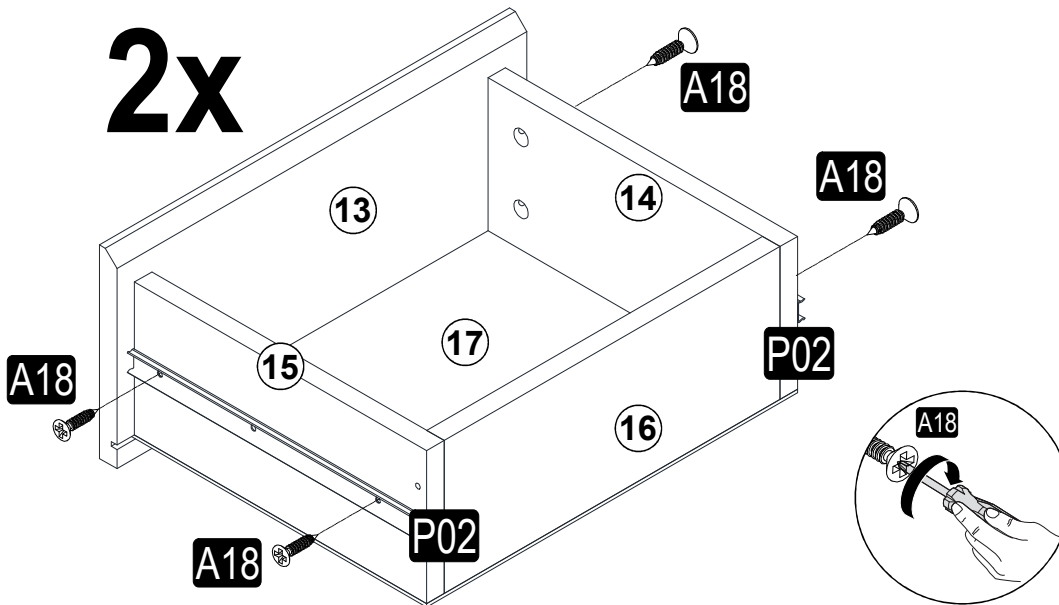

P02	TLSPKP RAY	2T
33x300		
A18	YHB VD	8x
3,5x18		

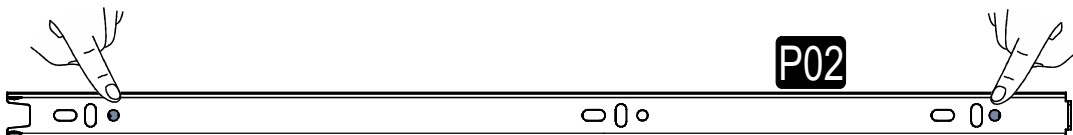

15

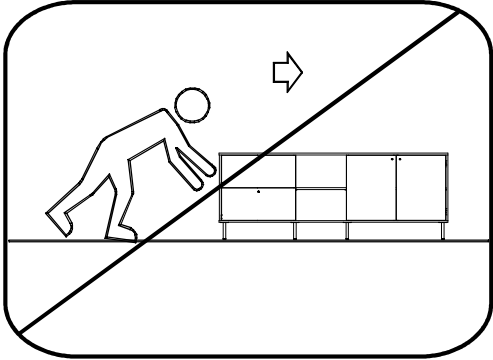
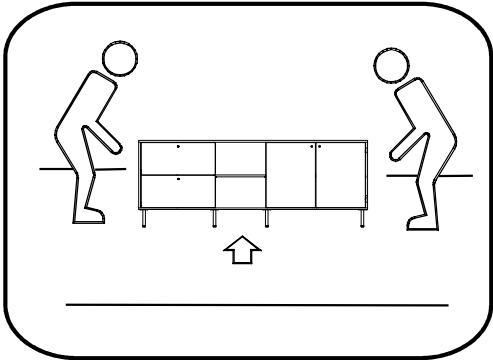
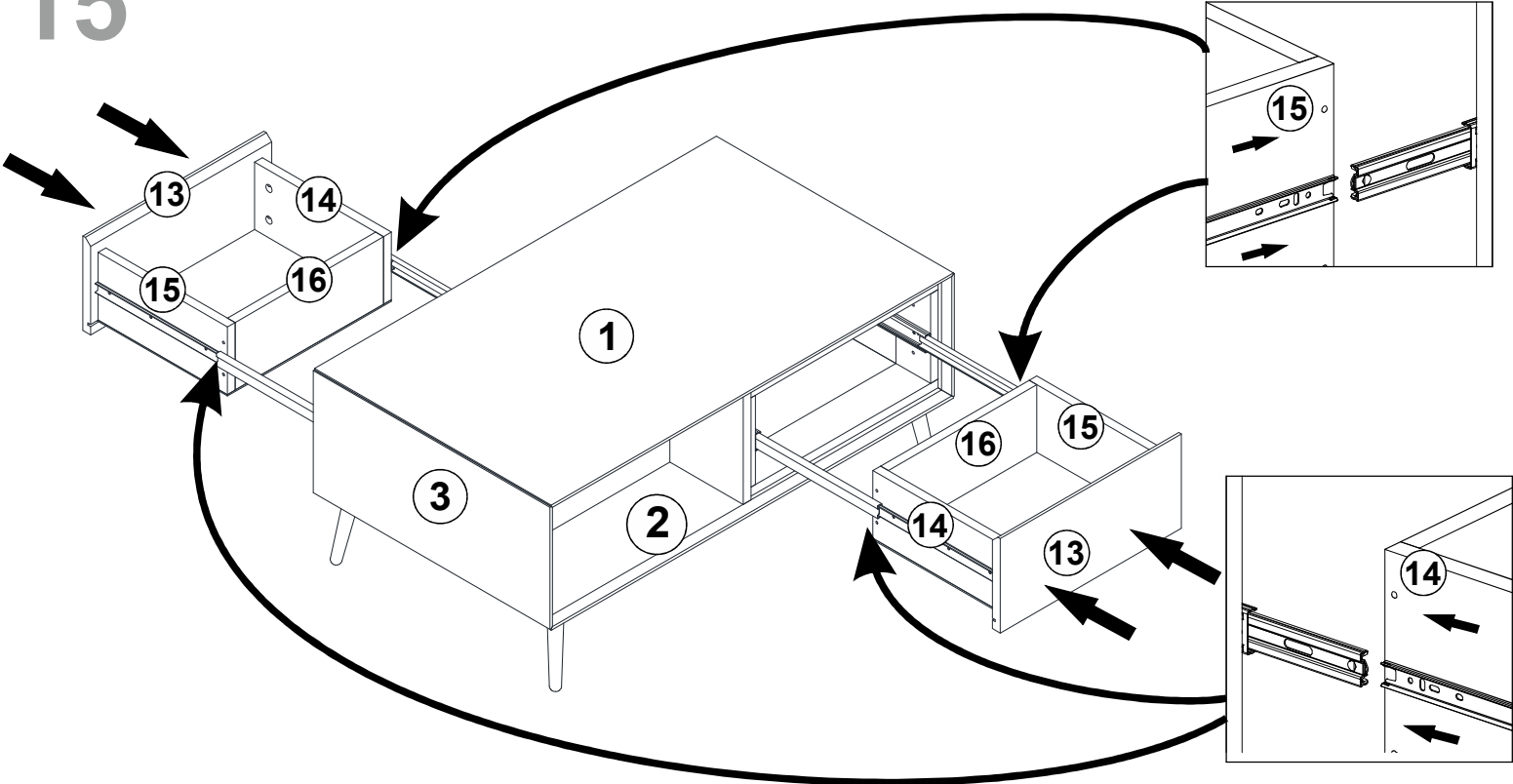

LE TRI + FACILE



FR

Pensez à donner ou recycler.



ou



ou



<https://quefairedemesdechets.fr>