

Modellname / Model name / Nom du modèle /  
Nome modello / Název modelu / Modelnaam / Ime modela  
Número Modelo / Modell neve / Nombre del modelo /  
Názov modelu / Ime modela / Denumire model /  
Nome do modelo

**Sole**

Modellnummer / Number / Numéro du modèle  
Numero / modello /  
Číslo modelu / Modell száma / Eíslo modelu  
Številka modela / Număr model

3153WA - Weiss / Artisan

Type / Tipo / Típus / Typ / Tip

**01**

29.01.2025

**D** Bitte lesen Sie diese Montageanleitung gut durch, da wir für Fehler, die durch falsche Montage entstehen, keine Haftung übernehmen!

**GB** Please read these installation instructions through carefully as we cannot accept any liability for faults occurring as a result of incorrect installation!

**CZ** Přečtěte si prosím pozorně tento návod k montáži, aby jste předešli chybám vzniklých špatnou montáží, za které neručíme!

**F** Veuillez lire attentivement cette notice de montage, car nous déclinons toute responsabilité en cas d'erreurs découlant d'un montage erroné !

**I** Prego leggere attentamente le istruzioni per il montaggio, poiché decliniamo qualsiasi responsabilità per difetti derivanti da un montaggio errato

**ES** Por favor lea estas instrucciones de instalación con cuidado, ya que no podemos aceptar ninguna responsabilidad por fallos que ocurran como resultado de una instalación incorrecta!

**NL** Leest u alstublieft deze montagehandleiding goed door, voor fouten door verkeerde montage zijn wij niet verantwoordelijk.

**PL** Proszę uważnie zapoznać się z instrukcją montażu, ponieważ nie ponosimy odpowiedzialności za niewłaściwy montaż.

**HR** Molimo vas da pažljivo prčitajte uputstva za sastavljanje, jer ne snosimo odgovornost za pogreske nastale zbog ne odgovarajućeg sastavljanja.

**HU** Kérjük, olvassa el figyelmesen ezt az összeszerelési útmutatót, mert a helytelen összeszerelésből a dódó hibákért nem vállalunk felelősséget!

**SK** Prosíme, dobre prečítajte si tento návod na montáž, pretože nepreberáme žiadne ručenie za chyby, ktoré vzniknú na základe chýbnej montáže!

**SLO** Preberite ta navodila za montažo, ker mi ne prevzemamo odgovornosti za napake, ki nastanejo kot posledica napacne montaže!

**RO** Vă rugăm să citiți cu atenție aceste instrucțiuni de montaj deoarece nu preluăm garanția pentru defecte ce apar datorită unui montaj incorect!

**PT** Leia estas instruções de instalação cuidadosamente, pois não podemos aceitar qualquer responsabilidade por falhas que ocorram como resultado de uma instalação incorreta!

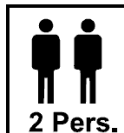
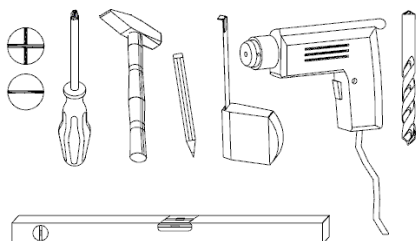
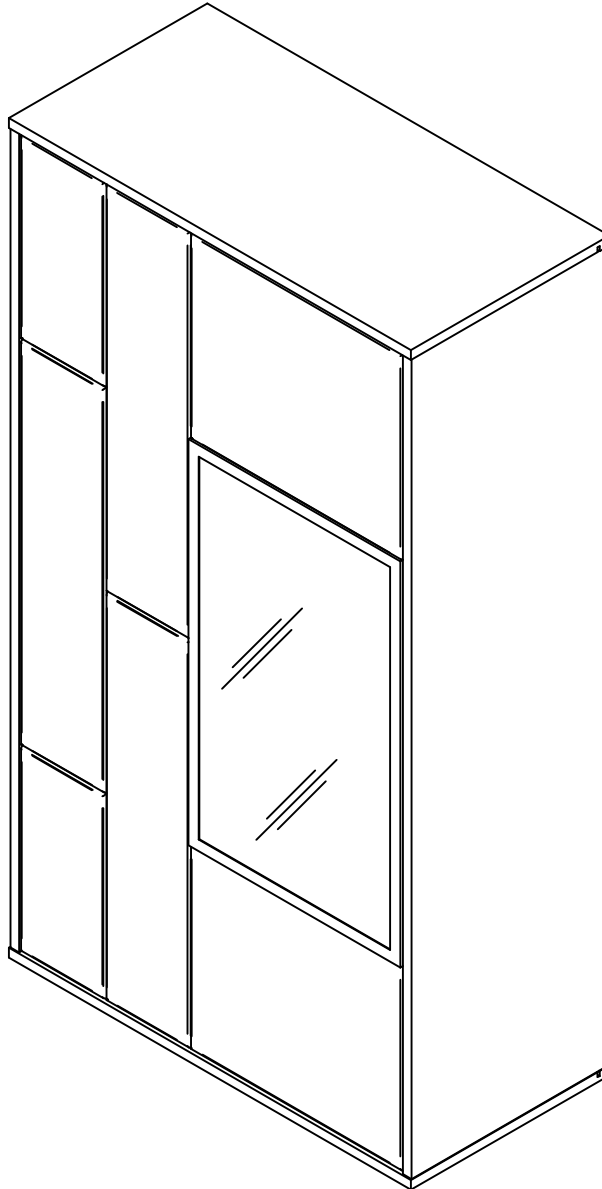

2 Pers.

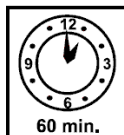

60 min.



festziehen / tighten / apretar /  
serrer / stringere utahnout / vasttrekken /  
zategnuti/strângere / zwiázac /  
szorosan meghúzni / pevne dotiahnut /  
trdno pritegniti / apertar /



eindrücken / press in / enfoncer /  
ribattere / zatlačit / presionar /  
Benyomni / stlačit / vtisniti / pressione  
introducere prin apasare /



ausmessen / measure / mesures /  
misurare / opmeten / izmeriti / miara /  
kimérni / izmeriti / masurare / medida  
zméřit / a medida



drücken / press / presser / stisknout /  
HaTNCHeTe /vtisniti / nasinac / drukken /  
pritisnuti / nacisnac / pritisniti / prensa /  
(Meg)nyomni / apasare /



einschlagen / hammer in / bevern / sla in  
frapper au marteler / infossare / Zabit' /  
zarazit / virar / zabiti /  
Introducere prin bătăie / tacha



Drehen - wenden / Proszę odwrócić /  
Keren - omdraaien / Girare - Ruotare /  
Okrenuti - ubnuti / Retourner - renverser /  
Turn over - turn around / Otočte - obratite /  
Giro de vuelta / Obrnite list /  
Introarceti / rotiti /

Sehr geehrter Kunde,

als Möbelproduzent möchten wir Sie darüber informieren, dass eine Befestigung nur so gut ist wie die Verbindung zwischen Befestigungsmaterial (Dübel) und Mauerwerk. Prüfen Sie bei Hängeelementen Ihr Mauerwerk und verwenden Sie nur dafür vorgesehene Dübel aus einem Fachmarkt. Letztendlich ist der Monteur für die Befestigung am Mauerwerk verantwortlich.

Die Montage und das Verlegen der Elektroartikel sind nur von autorisiertem Fachpersonal durchzuführen. Beachten Sie die Beschreibungen und die Gewichtsangaben in der Montageanleitung.

Halten Sie bitte die angegebenen max. Gewichtsangaben ein. Bei Überlastungen, die durch spielende Kinder, Menschen, Material oder sonstige Einwirkungen entstehen -übernehmen wir als Möbelproduzent keine Haftung!

Die einwandfreie Funktion des Möbels ist nur bei lot- und waagerechter Aufstellung gewährleistet. Die Türen sind vorjustiert, müssen aber ggf. aufgrund örtlicher Bedingungen neu ausgerichtet / eingestellt werden!

Alle elektrischen Installationen sind nach den gültigen Normen bzw. Vorschriften von VDE, CE, MM gefertigt. Die zu verwendende Leuchtmittelstärke ist auf der jeweiligen Lampenfassung angegeben.

Bei Nichteinhaltung der max. Wattzahl besteht durch Überhitzung Brandgefahr. Das Zudecken der Leuchtmittel ist wegen Brandgefahr zu unterlassen!

Alle Schrauben sowie tragende Verbindungsstelle sollten nach 5 bis 6 Wochen nachgezogen werden, um eine dauerhafte Standsicherheit zu gewähren!

#### **Keine scheuernden Putzmittel verwenden!**

Werden Betriebs-, Bedienungs- oder Montageanweisungen nicht befolgt, Änderungen an den Produkten vorgenommen, Teile ausgewechselt oder Verbrauchsmaterialien verwendet, die nicht den Originalteilen entsprechen, so entfällt jegliche Gewährleistung oder Haftungsansprüche.

Dear Customer,

As a furniture manufacturer we would like to point out that an attachment is only as good as the connection between the attachment material (dowel) and masonry. In the case of suspension elements you should check your masonry and only use the appropriate dowels from a specialist store. Ultimately it is the person carrying out the installation who is responsible for attachment to the masonry.

The installation and laying of electrical lines and other items must only be performed by authorised specialists. Please note the descriptions and weight information in the installation instructions.

Please observe the stated maximum weights; in the case of mechanical overloads caused by playing children, other individuals, materials etc. we do not accept any liability as the manufacturer of the furniture!

The furniture is only guaranteed to work perfectly if it is set up to be plumb and horizontal. The doors have been pre-adjusted, but may need to be realigned/readjusted in accordance with local conditions!

All electrical installations have been produced in accordance with the latest norms and regulations, such as those of the VDE (Association of German Electrical Engineers), CE and MM. The power of the bulbs to be used is marked on the respective light fitting.

If the maximum number of watts stated on the fitting is not complied with, there is a danger of fire from overheating. Covering the lamps and bulbs is strictly prohibited due to the danger of fire!

All screws and load-bearing connecting parts should be tightened after 5 to 6 weeks in order to ensure long-term stability!

#### **Do not use any abrasive cleaning materials!**

If the operating or installation instructions are not complied with, modifications are carried out to the products, parts replaced or consumable materials used which do not correspond to the original parts, all warranty or liability claims shall become null and void.

Vážený zákazník,

jako výrobce nábytku bychom Vás chtěli informovat o tom, že upevnění je jen tak dobré, jak dobré je spojení mezi upevňovacím materiálem (hmoždinkou) a zdívkou. U závěsných prvků zkontrolujte příslušné zdivo a používejte jen vhodné hmoždinky, které nakoupíte v odborných obchodech. Za upevnění ve zdivu je nakonec zodpovědný ten, kdo upevnění montuje.

Montáž a instalaci elektrických částí smí provádět jen pověřeni odborní pracovníci. Dodržujte popisy a údaje o hmotnosti uvedené v návodu k montáži.

Dodržujte uvedené údaje o maximální hmotnosti – při přetížení, které je způsobeno hrajícími si dětmi, lidmi, materiálem nebo jinými vlivy, nepřebíráme jako výrobce nábytku žádnou záruku!

Bezvadná funkce nábytku je zaručena jen při postavení nábytku ve správné svislé a vodorovné poloze. Dvířka jsou předem nastavená, případně je ale nutné je znovu seřídit / nastavit podle místních podmínek!

Všechny elektrické instalace jsou provedeny podle platných norem příp. předpisů VDE (svaz německých elektrotechniků), CE, MM. Intenzita žárovky/zdroje světla, která se má použít, je uvedena na příslušné objímce žárovky/zdroje světla.

Při nedodržení maximálního výkonu ve Wattedech hrozí nebezpečí vznícení kvůli přehřátí. Zakrytí žárovky/zdroje světla je kvůli nebezpečí požáru zakázáno!

Všechny šrouby a nosné spojovací prvky se mají po 5 až 6 týdnech dotáhnout, čímž se zajistí trvalá stabilita!

#### **Nepoužívejte žádné odírající čisticí prostředky!**

Pokud se nedodržují pokyny k provozu, návodu nebo montáži, provádí se změny výrobků, vyměňují se díly na neoriginální nebo se používá spotřební materiál, který neodpovídá originálnímu, odpadá každá záruka nebo nároky na ručení.

Vážený zákazník,

ako výrobca nábytku by sme Vás chceli informovať o tom, že nové upevnenie je len také dobré, aké dobré je spojenie medzi spojovacím materiálom (hmoždinky) a murivom. Pri visiacich elementoch skontrolujte Vaše murivo a použite na príslušné murivo iba určenú hmoždinku zo stavebnín. V konečnom dôsledku je za upevnenie na murive zodpovedný montér.

Montáž a pokládka elektrických materiálov a spotrebičov smie vykonávať iba autorizovaný odborný personál. Prosíme, dodržte popisy a údaje o hmotnosti v návode na montáž.

Dodržiavajte uvádzané údaje o maximálnej hmotnosti – pri preťažení, ktoré môžu spôsobiť hrajúce sa deti, ľudia, materiál, alebo iné vplyvy - my, ako výrobca nábytku nepreberáme žiadne ručenie!

Bezchybná funkcia nábytku je zaručená iba pri kolmom a vodorovnom postavení. Dvere sú vopred nastavené, v prípade potreby na základe miestnych podmienok je však nutné ich znovu vyvážiť/nastaviť!

Všetky elektrické inštalácie sú zhotovené podľa platných noriem, resp. predpisov VDE, CE, MM. Sila osvetľovacích telies, ktoré sa majú použiť, je uvedená objímkach príslušných žiaroviek.

Pri nedodržaní maximálnych Wattov vzniká na základe prehriatia riziko požiaru. Neprikrývajte osvetľovacie telesá kvôli riziku požiaru!

Všetky skrutky, ako aj nosné spojovacie diely by sa mali po 5 až 6 týždňoch dotiahnuť, aby bola zaručená trvalá stabilita!

#### **Nepoužívejte žádné drsné čisticí prostředky!**

Ak nebudú dodržané prevádzkové návody, návody na obsluhu alebo montáž, ak sa budú na produktoch vykonávať zmeny, vymieňať diely alebo ak sa bude používať spotrebný materiál, ktorý nezodpovedá originálnym dielom, odpadá akákoľvek záruka alebo akékoľvek nároky na ručenie.

## Szanowni Klienci!

Jako producent mebli pragniemy Państwu przypomnieć, że umocowanie mebli jest tak dobre, jak dobre jest połączenie pomiędzy materiałem mocującym (kołkiem rozporowym) a ścianą. Proszę zatem w przypadku elementów wiszących sprawdzić wytrzymałość muru i użyć do ich zamocowania wyłącznie przeznaczonych do tego kołków ze sklepu specjalistycznego. Ostateczną odpowiedzialność za przymocowanie do ściany ponosi monter mebli.

Montaż artykułów elektrycznych i ich ułożenie należy powierzyć wyłącznie autoryzowanemu personelowi. Proszę zastosować się do opisów oraz ciężarów podanych w instrukcji montażu.

Proszę przestrzegać podanych ciężarów maksymalnych. W przypadku nadmiernego obciążenia, powstałego w wyniku bawiących się dzieci, osób, materiału lub z innych powodów – jako producent mebli nie ponosimy odpowiedzialności!

Nienaganne funkcjonowanie mebla jest zagwarantowane wyłącznie w przypadku jego prawidłowego pionowego i poziomego ustawienia. Drzwi zostały odpowiednio ustawione, ale ze względu na warunki lokalne należy je ewentualnie ustawić na nowo/wyregulować!

Wszystkie instalacje elektryczne wykonano zgodnie z obowiązującymi normami lub przepisami VDE, CE, MM. Na każdej oprawce lampowej podana jest moc żarówek, których należy używać.

W przypadku nieprzestrzegania maksymalnej ilości watów istnieje niebezpieczeństwo pożaru w wyniku przegrzania. Żarówek nie wolno przykręcać ze względu na niebezpieczeństwo pożaru!

Dla zapewnienia trwałej stateczności po 5-6 tygodniach należy dokręcić wszystkie śruby i nośne elementy łączące! Nie używać żadnych środków czyszczących wymagających szorowania!

W przypadku nieprzestrzegania instrukcji użytkowania, obsługi i montażu, dokonywania zmian w produktach, wymiany części lub używania materiałów zużywających się, które nie odpowiadają częściom oryginalnym, wyklucza się jakąkolwiek gwarancję lub roszczenia z tytułu odpowiedzialności cywilnej.

## Cher client,

En tant que fabricant de meubles, nous souhaitons attirer votre attention sur le fait que la meilleure des fixations n'est rien sans la qualité du raccord entre le matériel de fixation (cheville) et la maçonnerie. Par conséquent, pensez à vérifier la maçonnerie avant d'accrocher les éléments hauts et utilisez uniquement les chevilles prévues à cette fin, achetées dans une grande surface spécialisée. En fin de compte, c'est l'installateur qui sera responsable de la fixation à la maçonnerie.

Le montage et la pose des articles d'électroménager sont strictement l'affaire d'un personnel qualifié, dûment habilité. Veuillez observer les descriptions et les poids indiqués dans la notice de montage.

Veuillez respecter les poids maxi spécifiés ; en tant que fabricant de meubles, nous déclinons toute responsabilité en cas de surcharges causées par des enfants qui jouent, d'autres personnes, du matériel divers ou provoquées par d'autres influences !

Pour assurer le fonctionnement irréprochable du meuble, il faut veiller à l'installer parfaitement d'aplomb et à l'horizontale. Les portes sont préajustées, mais il sera peut-être nécessaire de les réaligner/régler à nouveau sur place !

Toutes les installations électriques sont fabriquées selon les normes et prescriptions VDE, CE, MM en vigueur. La puissance à utiliser est précisée sur la douille de chaque lampe.

Si le wattage max. n'est pas respecté, il existe un risque d'incendie dû à la surchauffe. Il est interdit de recouvrir la lampe, en raison du risque d'incendie !

Il faut resserrer toutes les vis et les éléments de raccord porteurs après 5 à 6 semaines, pour assurer une stabilité durable !

### N'employez en aucun cas des nettoyeurs abrasifs !

Si les instructions de service, de commande ou de montage ne sont pas respectées, si des modifications sont apportées aux produits ou bien encore si des pièces sont remplacées ou si des consommables qui ne correspondent pas aux pièces d'origine sont utilisés, nous n'assumons alors aucune garantie et nous déclinons toute responsabilité dans ces cas.

## Gentile cliente,

In qualità di produttori di mobili desideriamo informarla del fatto che un fissaggio può essere solo veramente buono se anche il collegamento tra il materiale di fissaggio (bullone) e le mura è altrettanto buono. Nel caso degli elementi che pendono controllate le vostre mura ed utilizzate solamente bulloni previsti a tale scopo che troverete in un mercato specializzato. Infine è il montatore colui che è responsabile per il fissaggio sulla parete.

Il montaggio e la messa in funzione degli apparecchi elettronici devono essere effettuati esclusivamente da personale specializzato. Si prega di rispettare le descrizioni e le indicazioni relative al peso presenti nelle istruzioni per il montaggio.

Si prega di rispettare le indicazioni relative al peso massimo - nel caso di un sovra-caricamento che può essere causato da bambini che giocano, da persone, da materiale oppure altri influssi si declina qualsiasi responsabilità!

Il funzionamento corretto del mobile è garantito solamente in caso di un montaggio corretto in posizione orizzontale e come riportato sull'imballaggio. Le porte sono già state anticipatamente pre-impostate, essere dovranno però, qualora necessario, essere adattate / regolate conformemente alle nuove condizioni ambientali!

Tutte le installazioni elettriche sono preparate secondo le norme e le regole vigenti VDE, CE, MM. La potenza dei mezzi d'illuminazione da utilizzarsi è riportata sul rispettivo zoccolo della lampada.



In caso di non-rispetto del numero massimo di Watt può verificarsi un surriscaldamento con il pericolo d'incendio. È vietato coprire i mezzi d'illuminazione perché sussiste il pericolo d'incendio!

Tutte le viti e gli elementi portanti di collegamento dovrebbero essere ri-aggiustati dopo 5 o 6 settimane al fine di garantire un funzionamento sicuro continuativo!



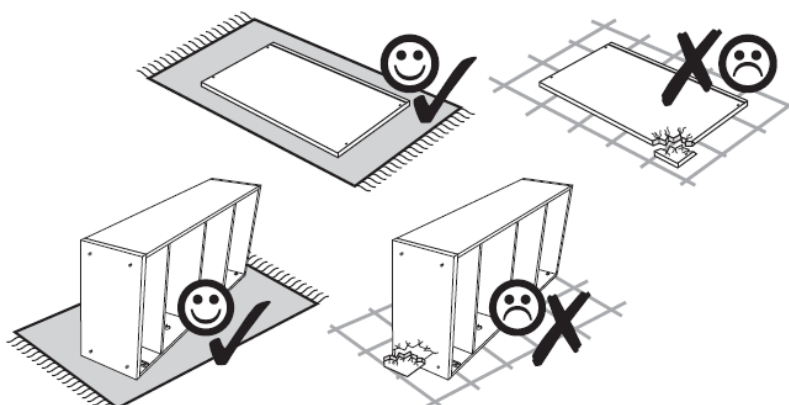
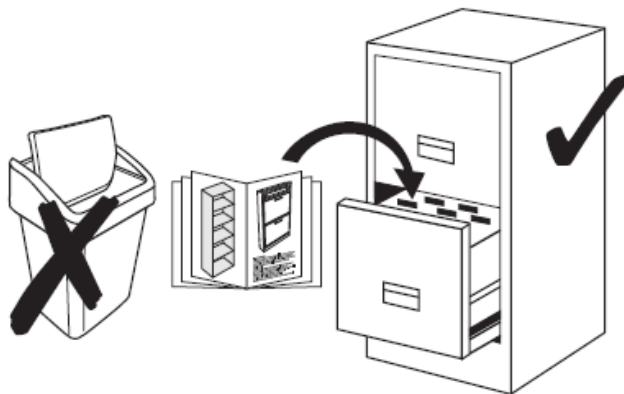
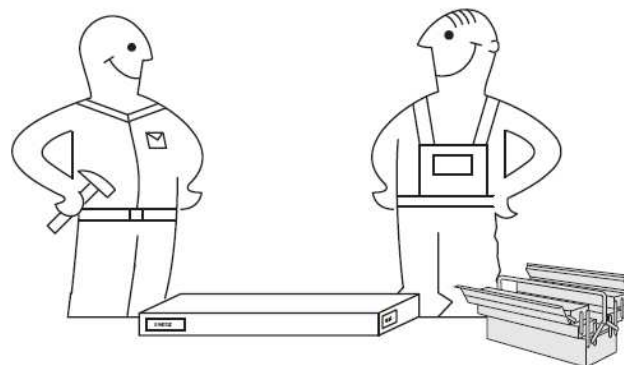



### Non utilizzare mezzi di pulizia che creino polvere di pulizia!

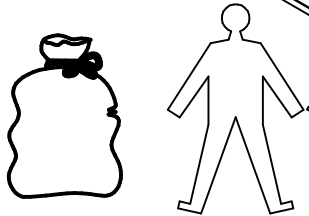
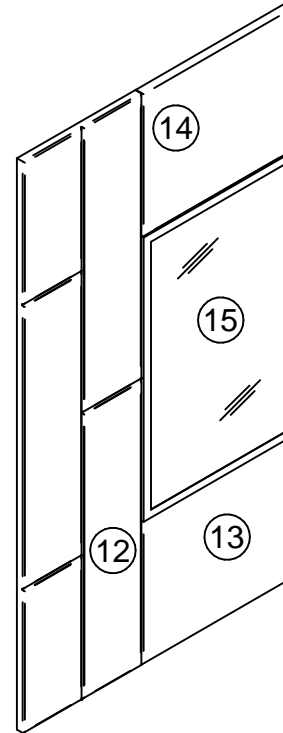
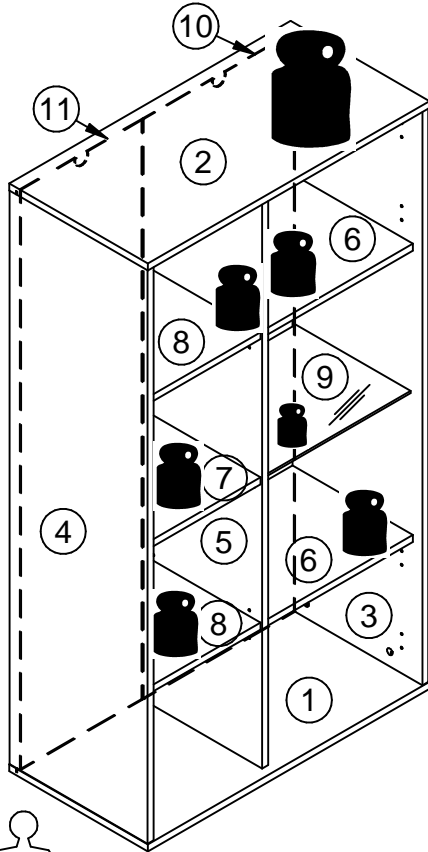





In caso di mancato rispetto delle indicazioni per l'esercizio, il comando o il montaggio, nel caso in cui venissero effettuate delle modifiche ai prodotti, in cui venissero sostituiti degli elementi oppure in cui venissero utilizzati dei materiali ausiliari che non corrispondono ai pezzi originali, allora non sarà più esigibile nessuna garanzia o nessuna richiesta di garanzia.

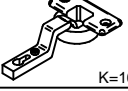
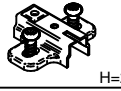

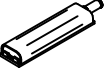
-  max. 30kg
-  max. 10kg
-  max. 5kg



BT1016  x30	MM1016  x24	MM1121  Ø8x30 x24	BT1142  x4	BT50101  x8	MM1202  Ø3,5x20 x14	BT50094  K=16 x7	BT1304  H=2 x7
--	--	---	---	--	---	--	--

MM1046  Ø3,5x13 x22	BT50496  x2	BT50238  80x80x10 x5	MM50051  Ø4x20 x10	BT50581  x4	BT1121  x2	BT50244.xxx  Ø20 x30
---	--	--	--	--	---	--

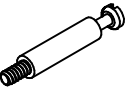
BT1005.xx  x8	MM50453  x6
--	--

1.



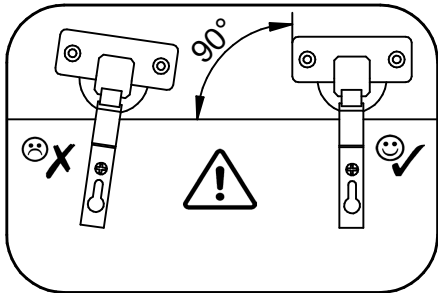
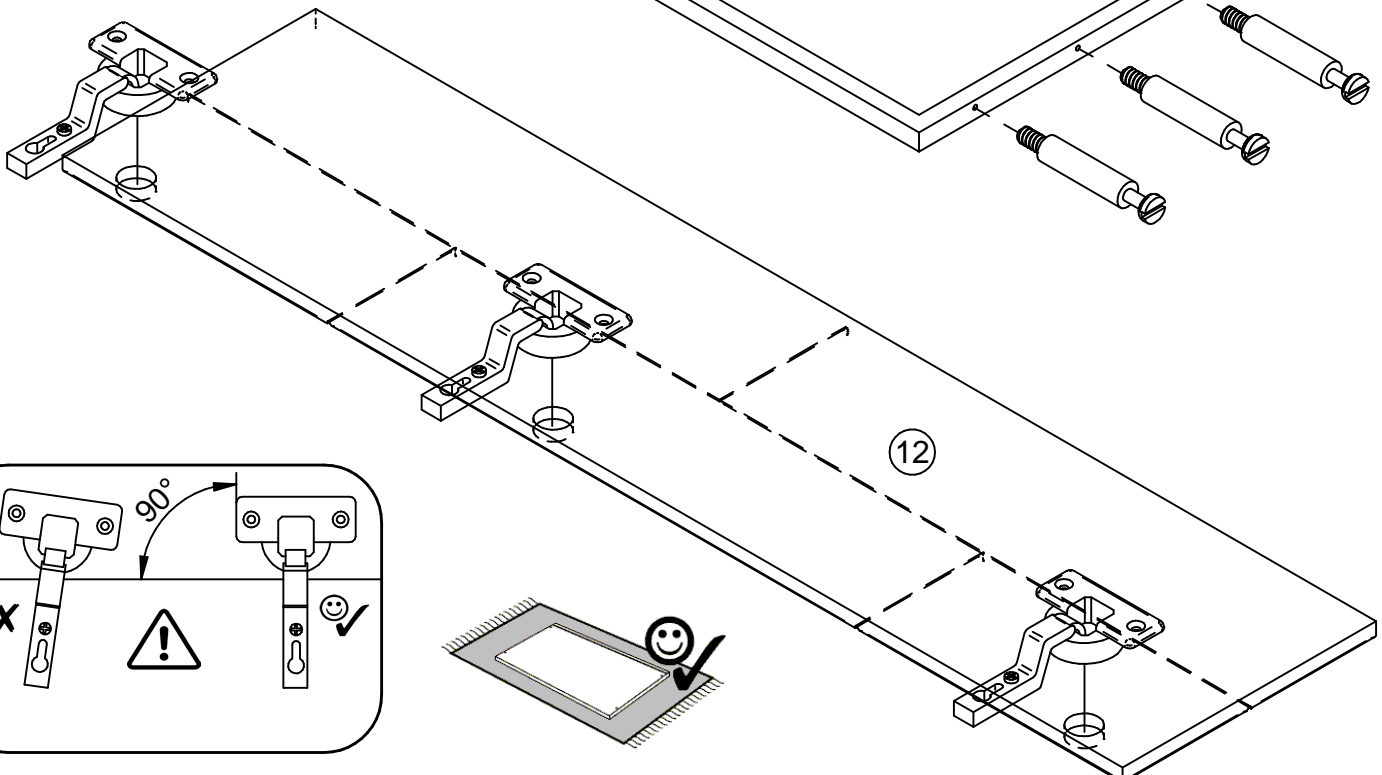
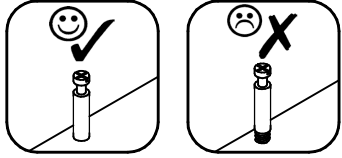
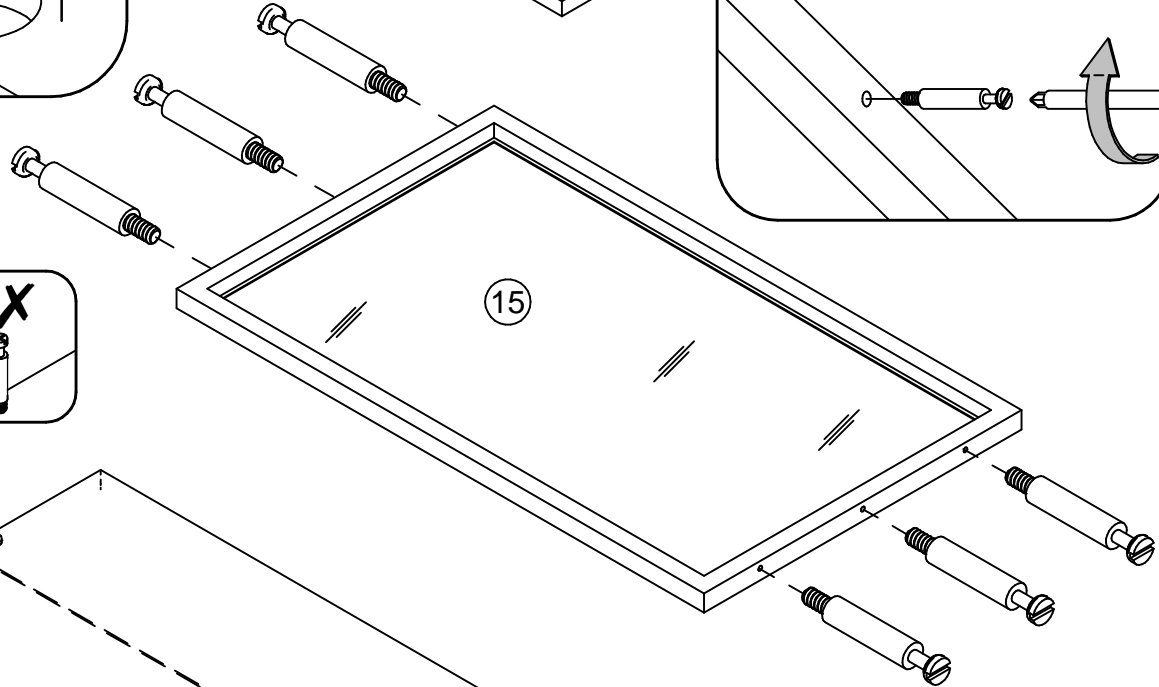
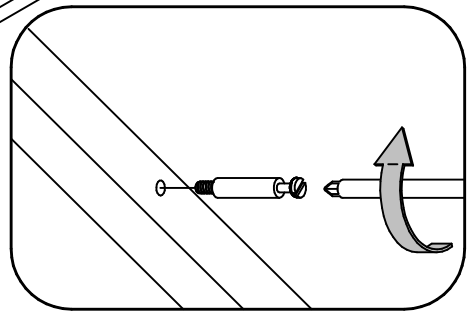
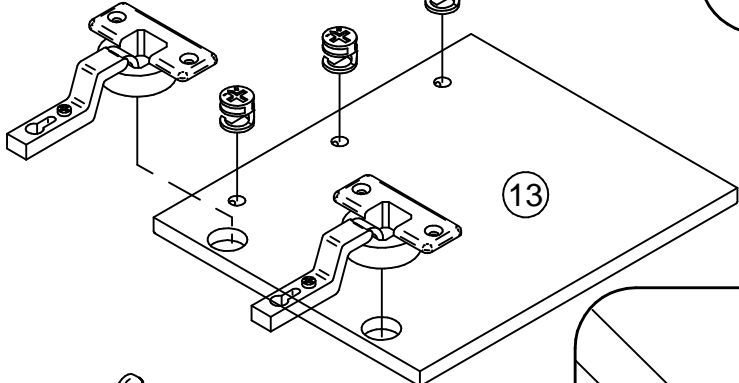
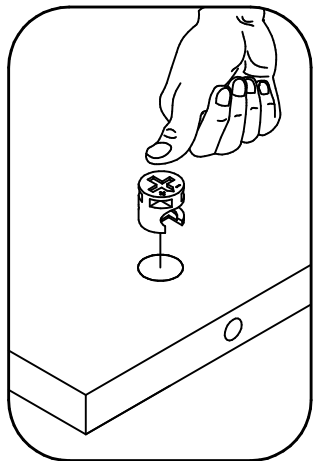
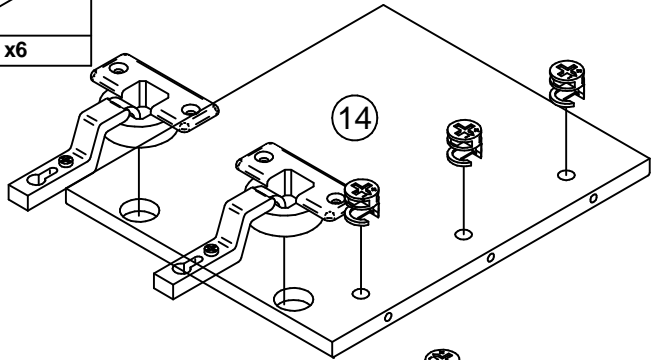
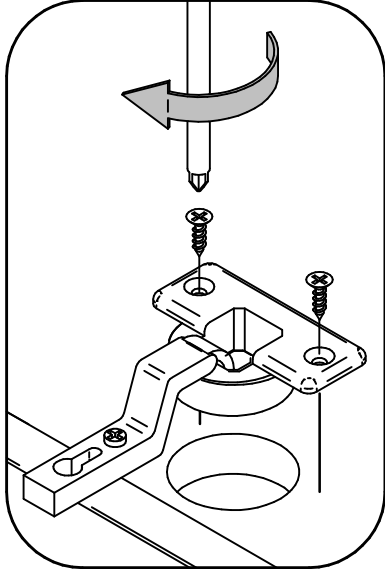

BT50094 K=16 x7	MM1046 Ø3,5x13 x14	MM50453 x6
BT1016 x6		

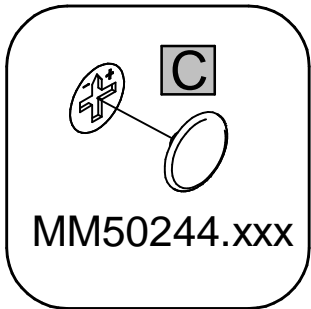
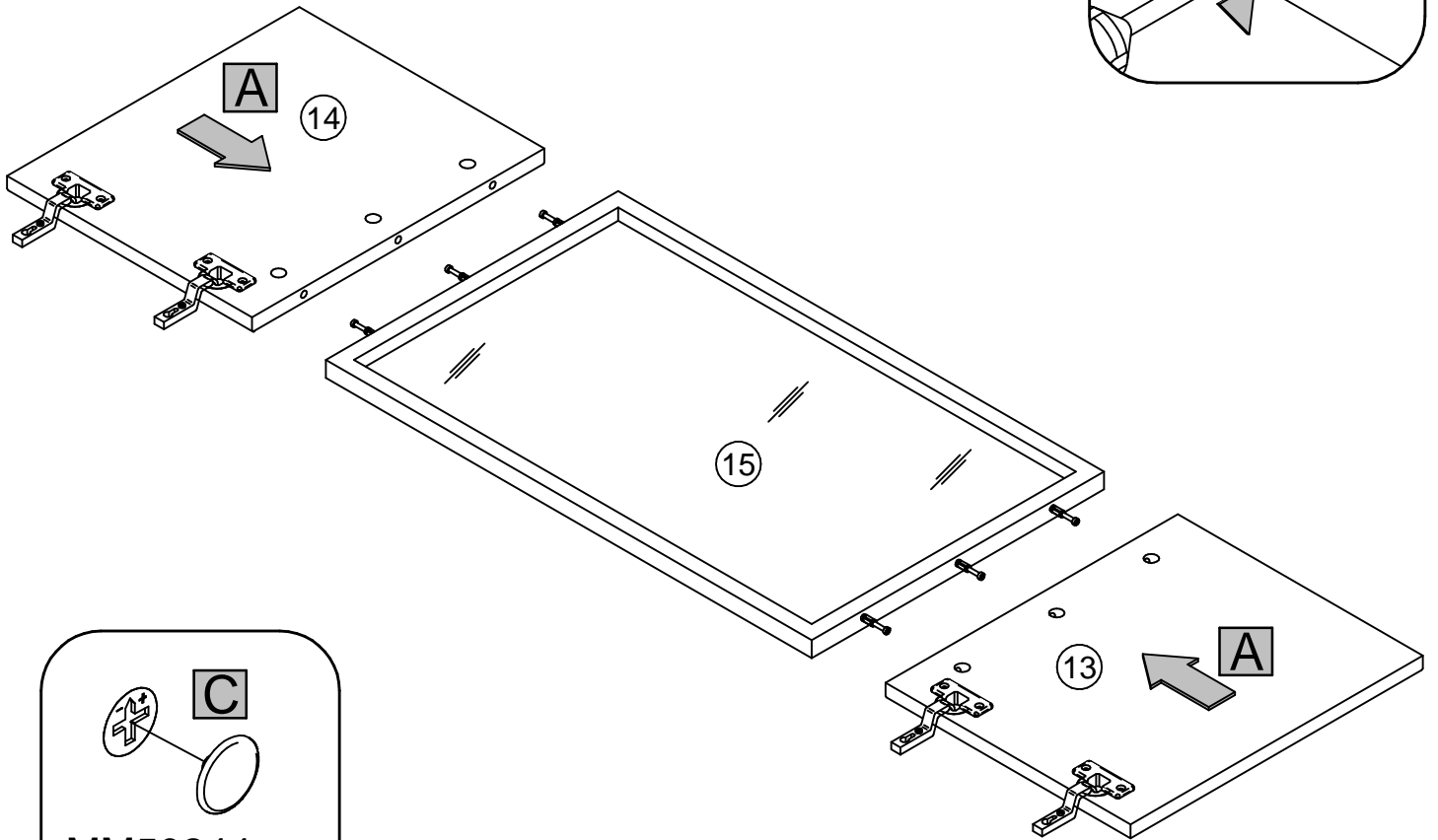
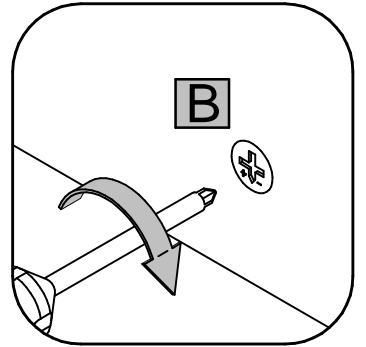
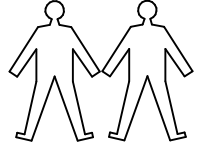
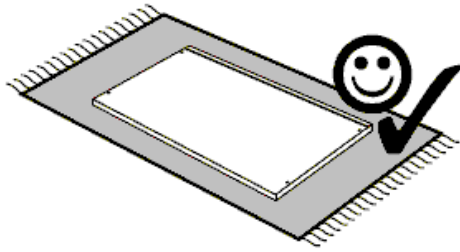
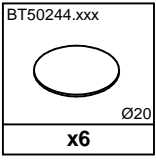

2.



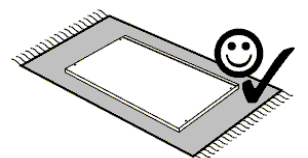
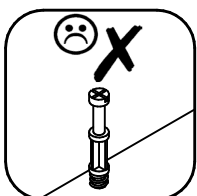
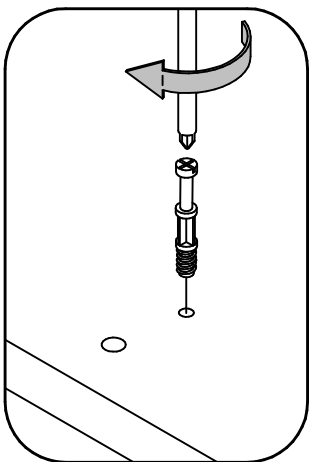
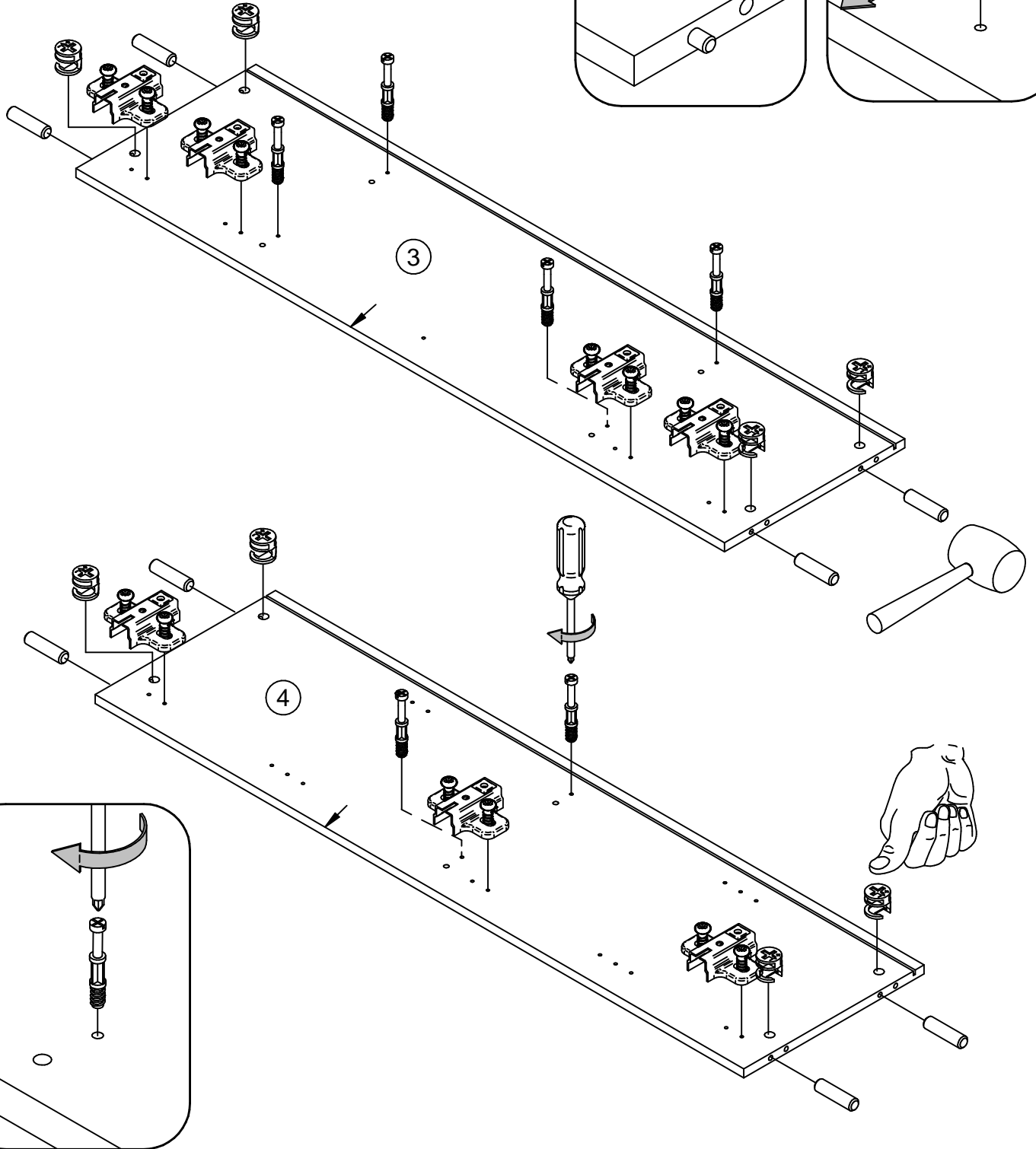
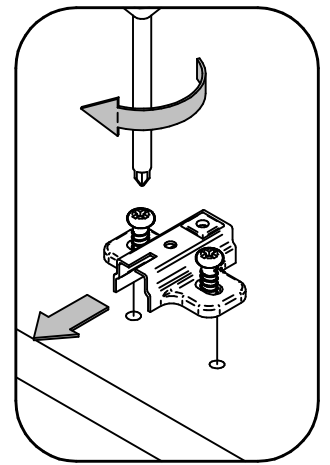
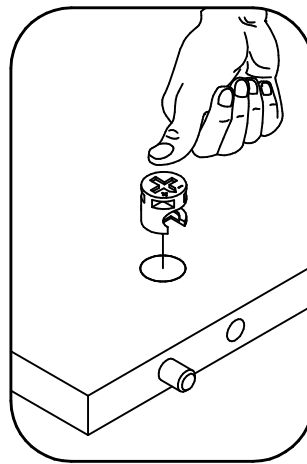

3.

BT1016  x8	MM1016  11mm x6	MM1121  Ø8x30 x8	BT1304  H=2 x7
--	---	---	---



4.

BT1016  x16	MM1016  11mm x6	MM1121  Ø8x30 x16
---	---	--

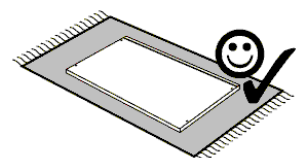
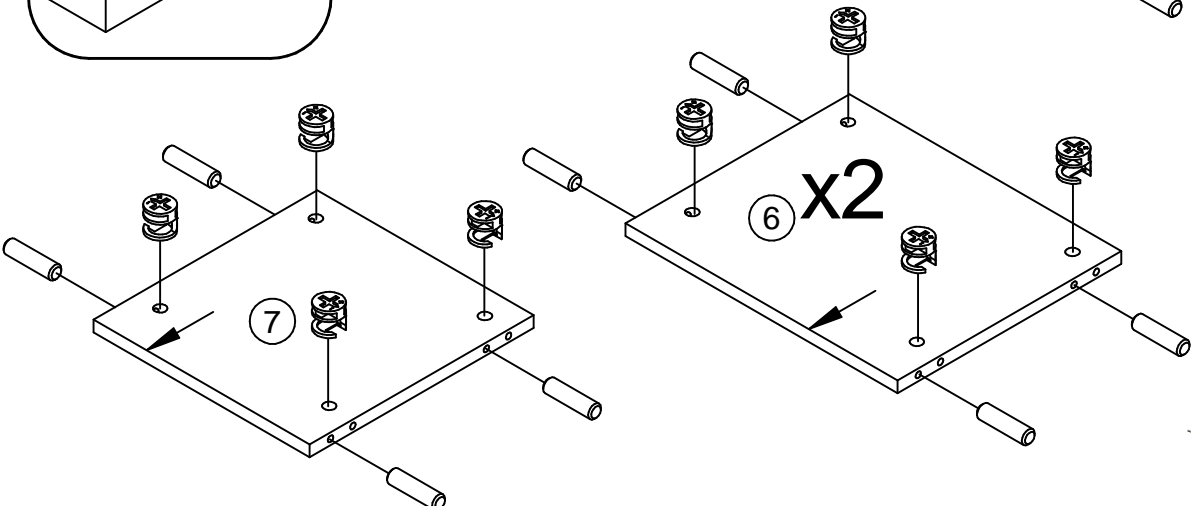
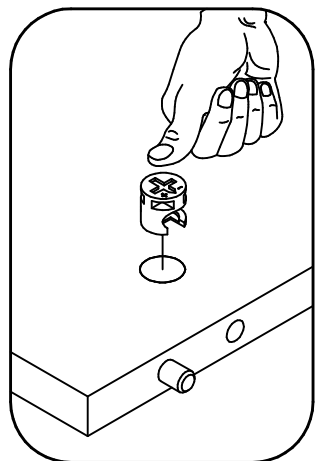
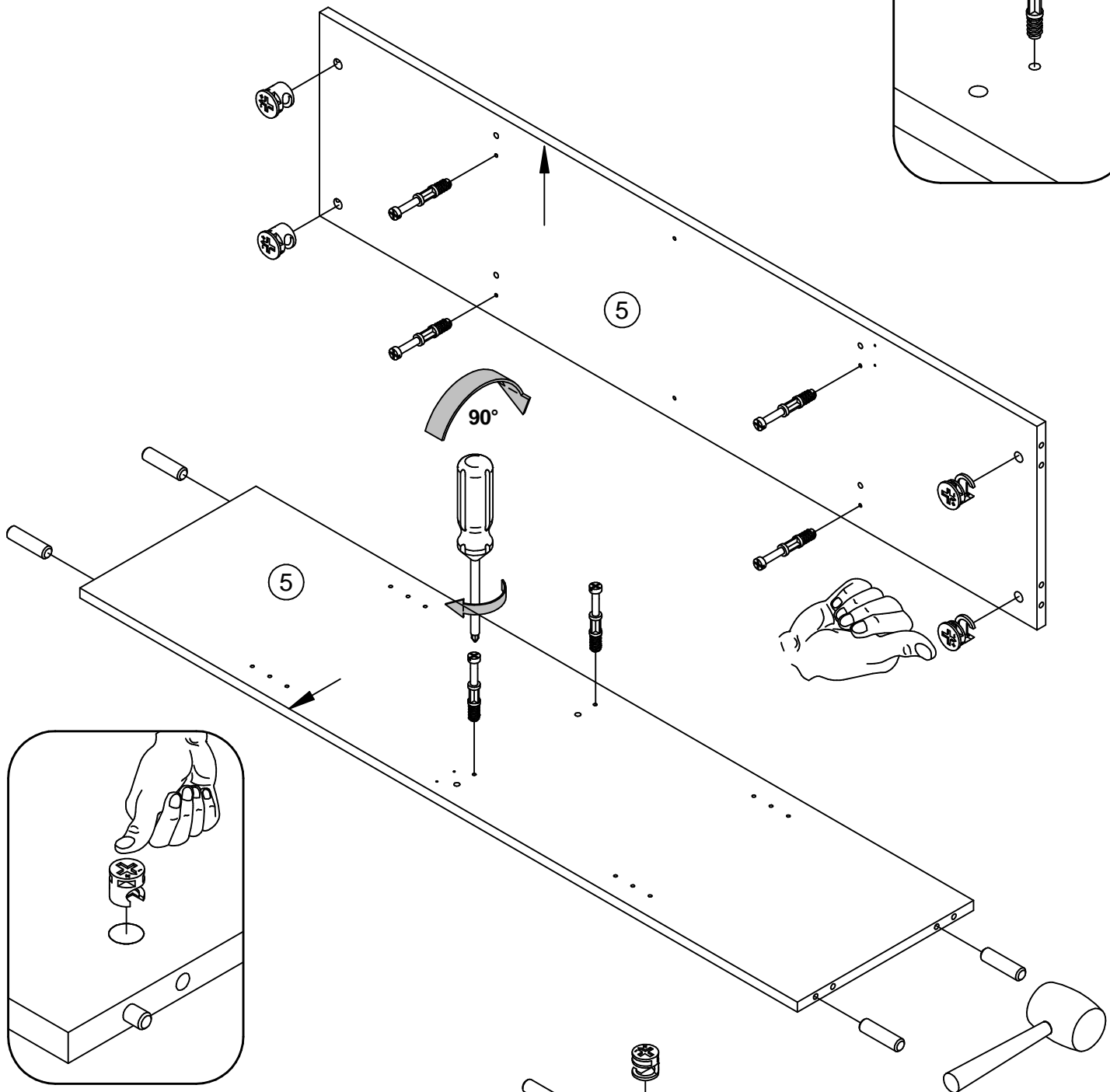
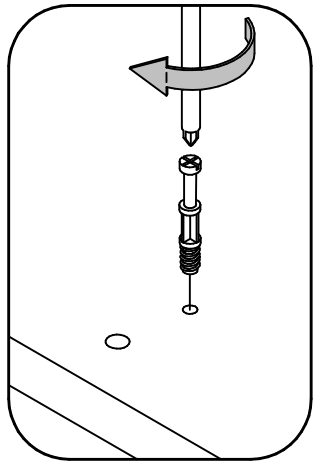
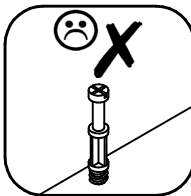
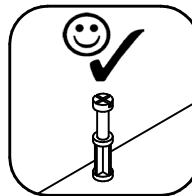



5.

BT50238 80x80x10 x5	MM50051 Ø4x20 ⚠ x10	MM1016 11mm x12	BT1121 x2	MM1046 Ø3,5x13 x4
---------------------------	---------------------------	-----------------------	--------------	-------------------------

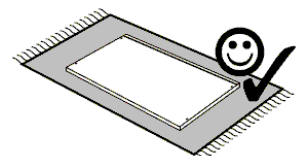
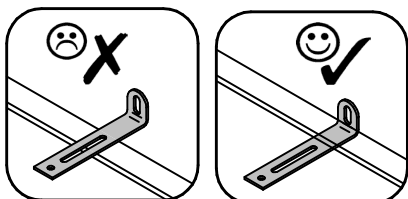
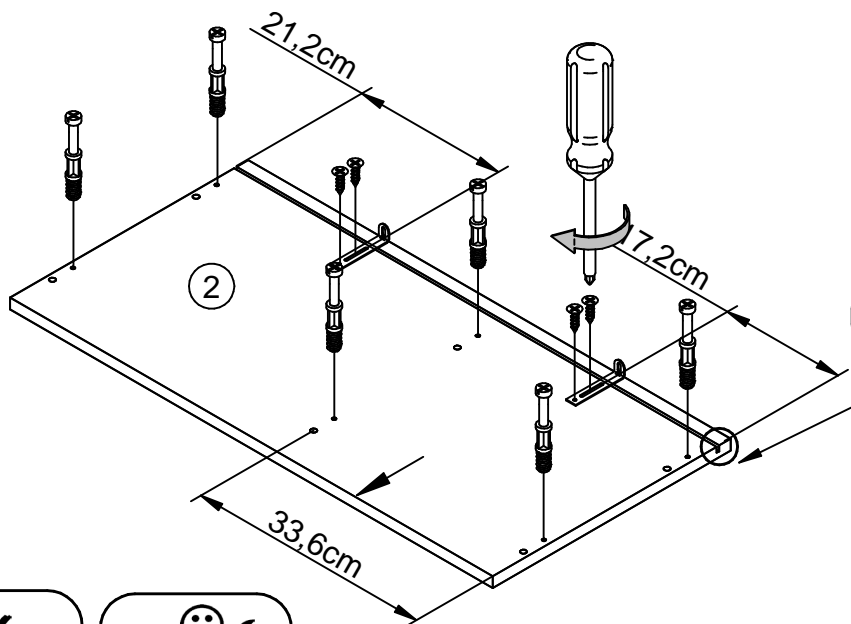
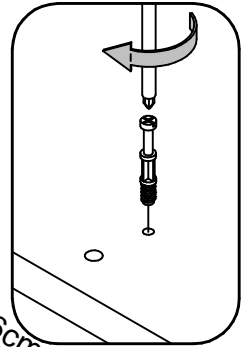
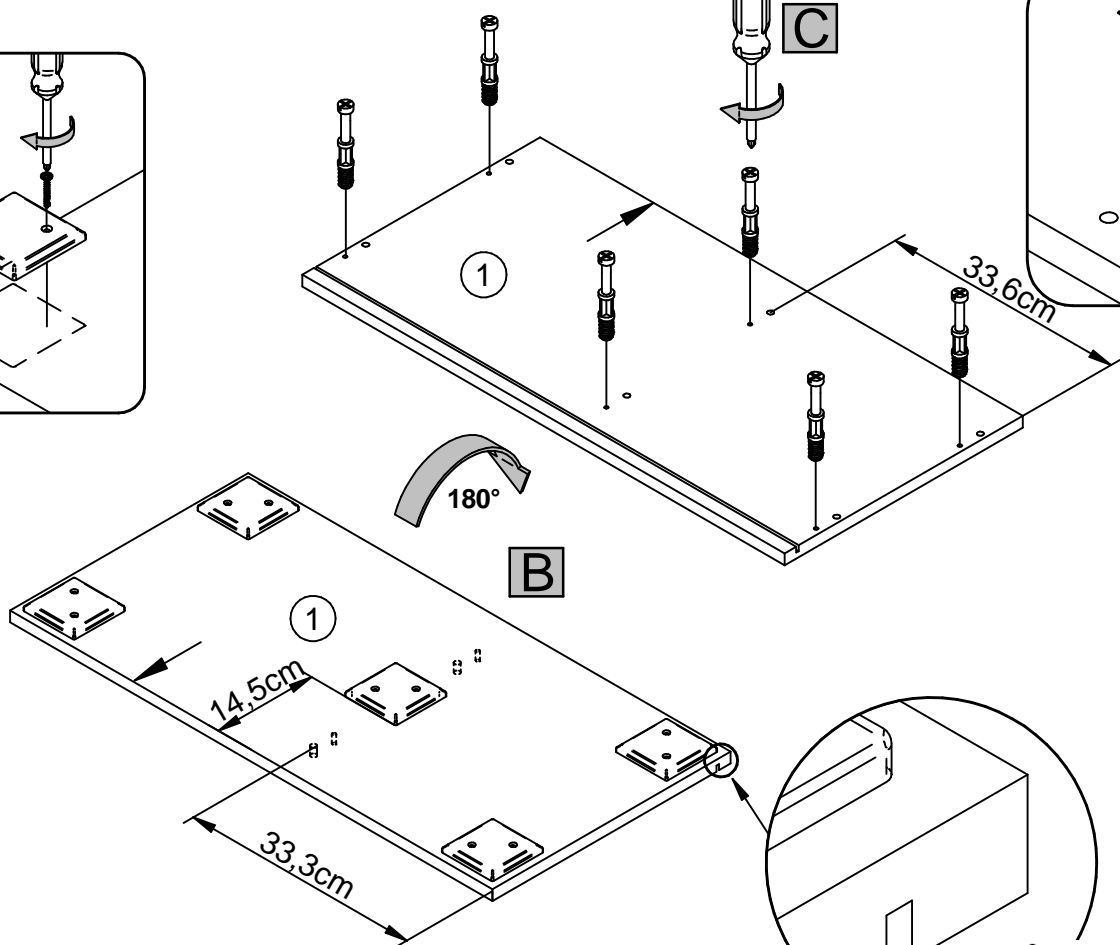
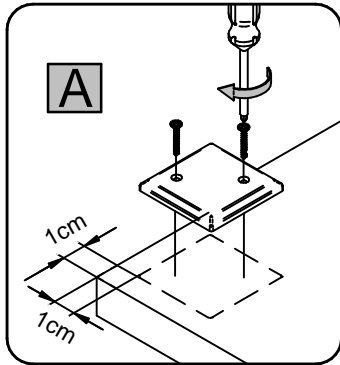
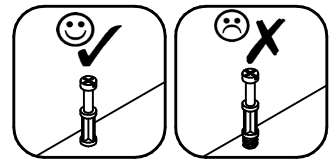

6.

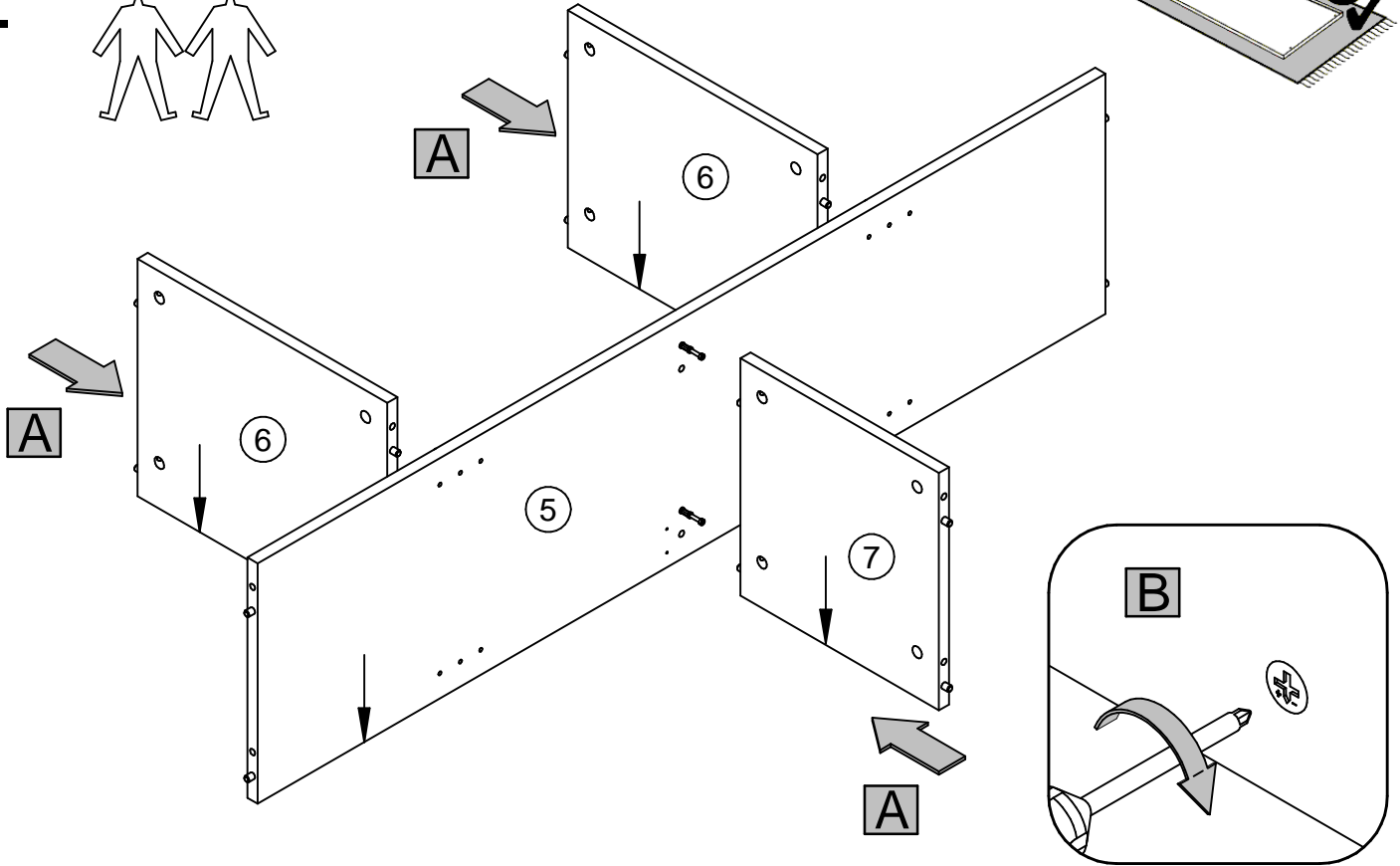
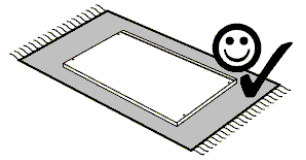
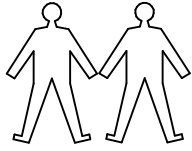

7.

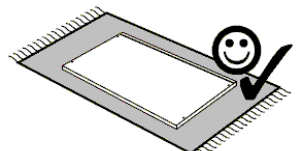
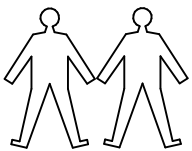
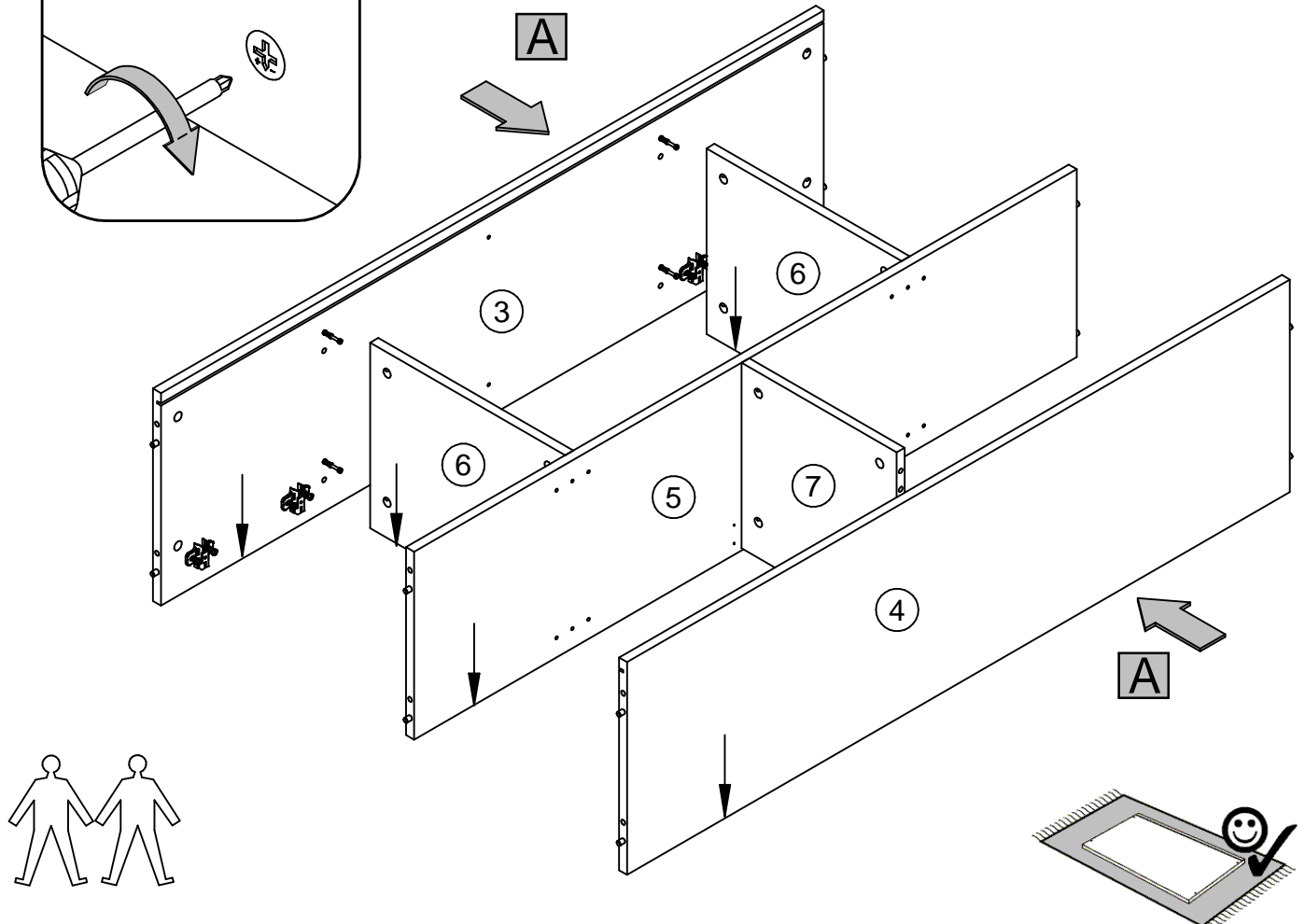
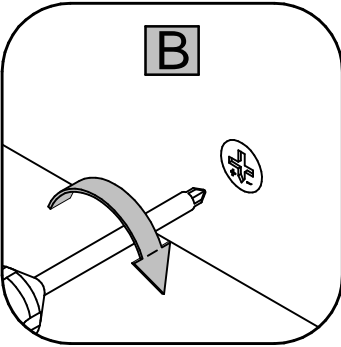

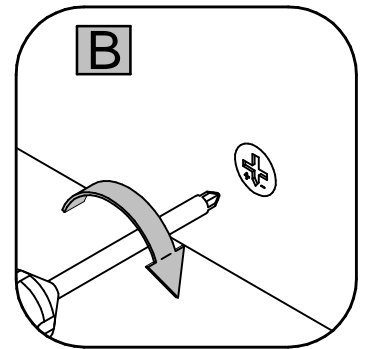
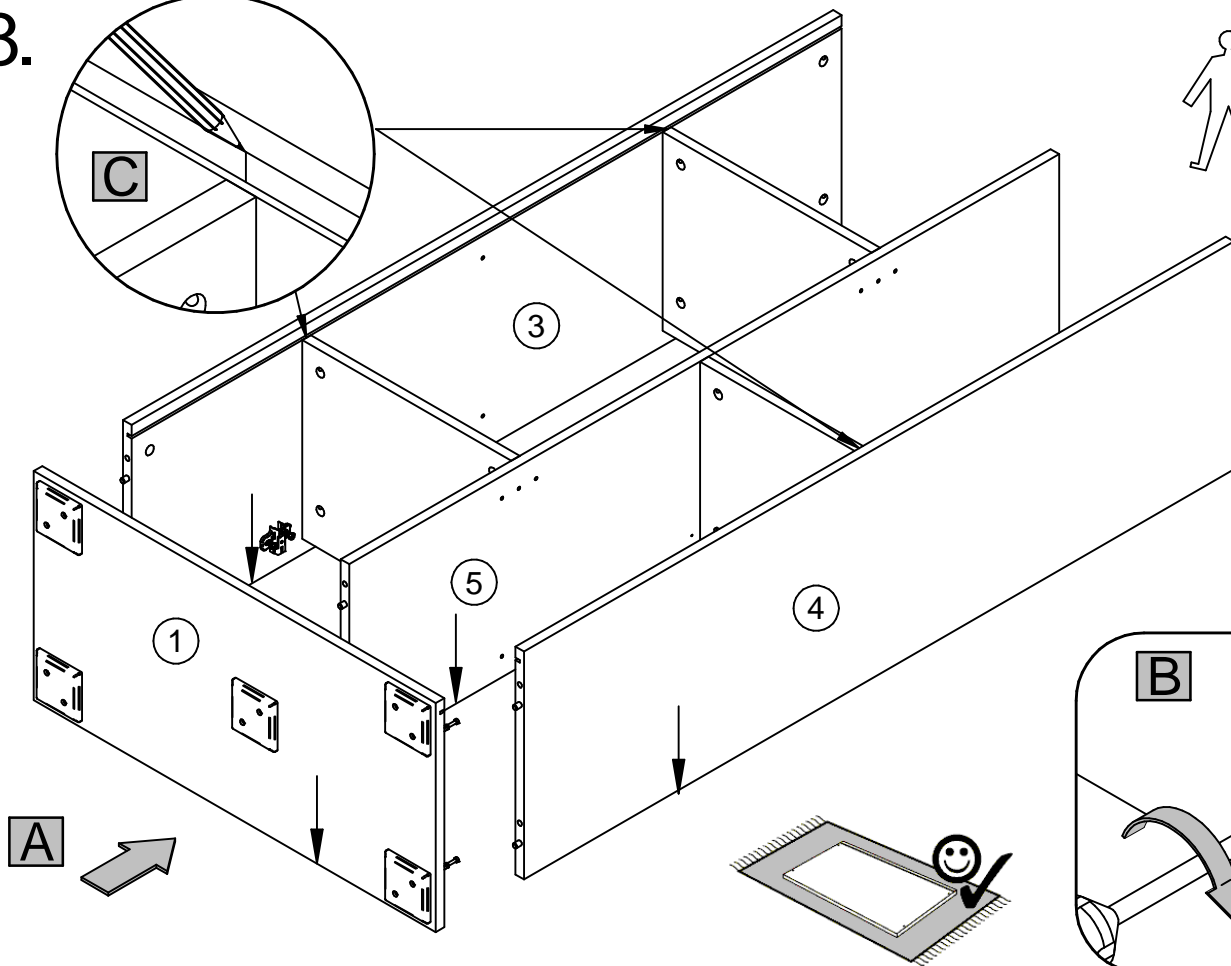
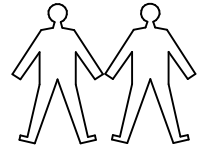
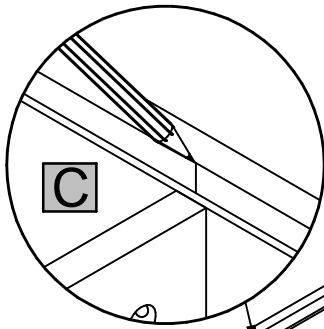

8.

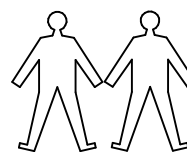
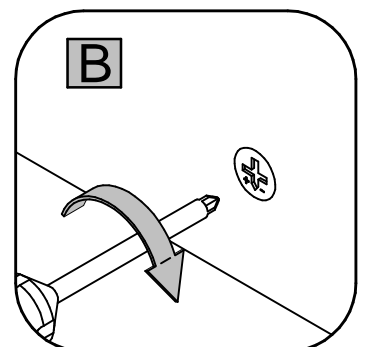
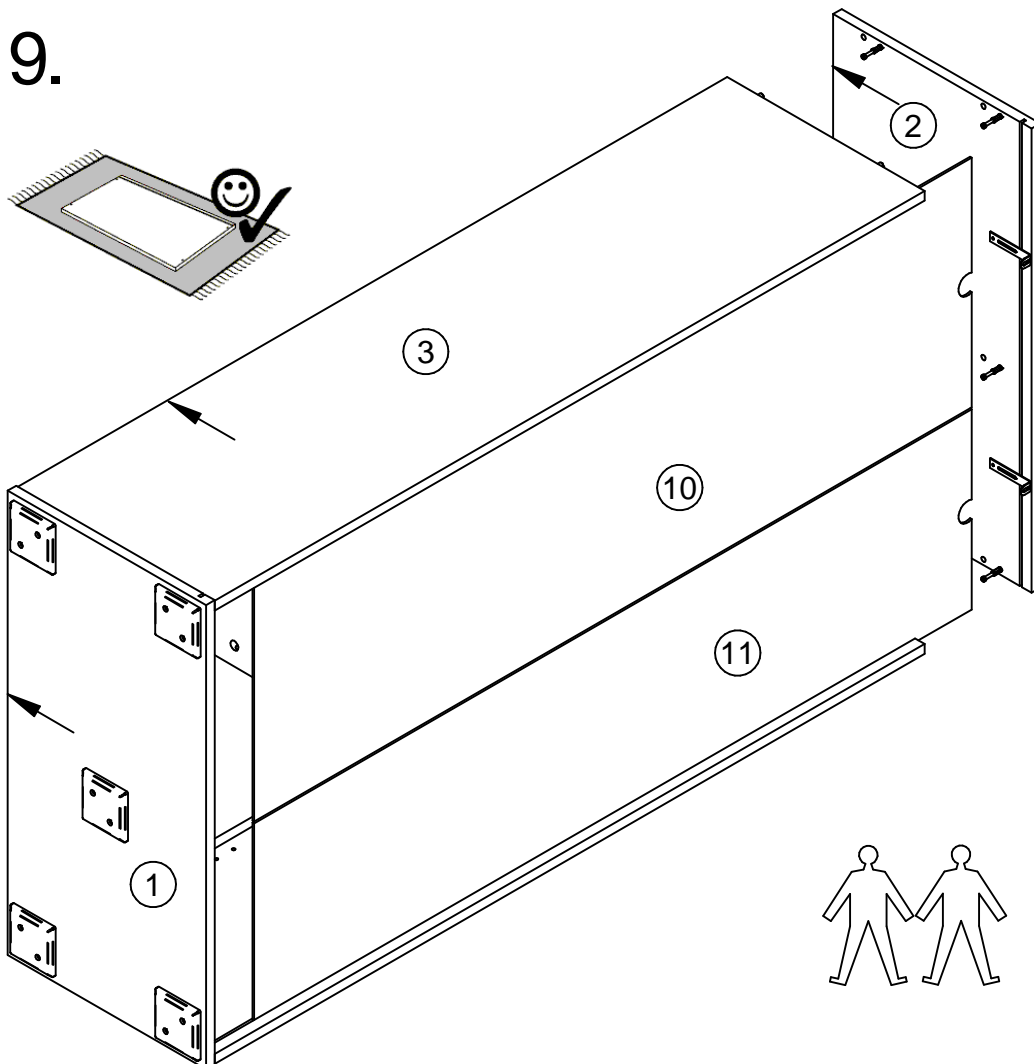
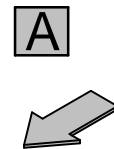
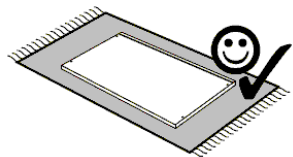

9.



10.

BT1142  x4	BT50101  x8	MM1202  Ø3.5x20 x14
--	--	--



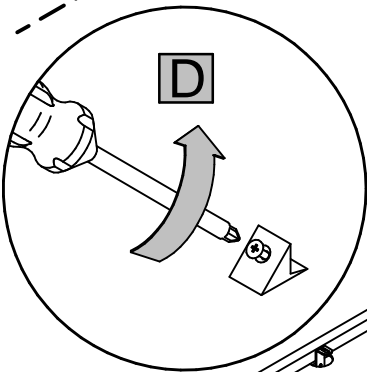
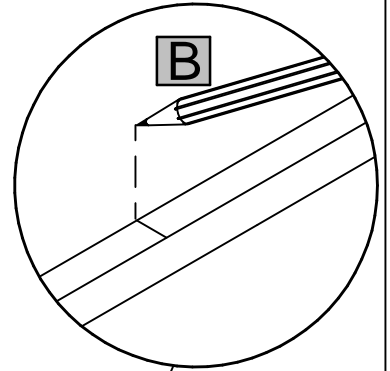
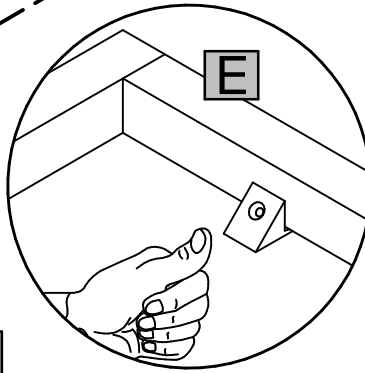
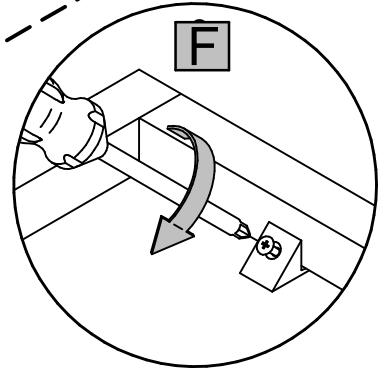
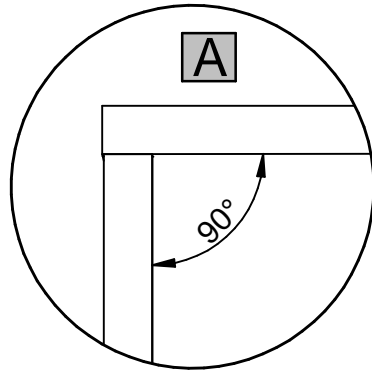
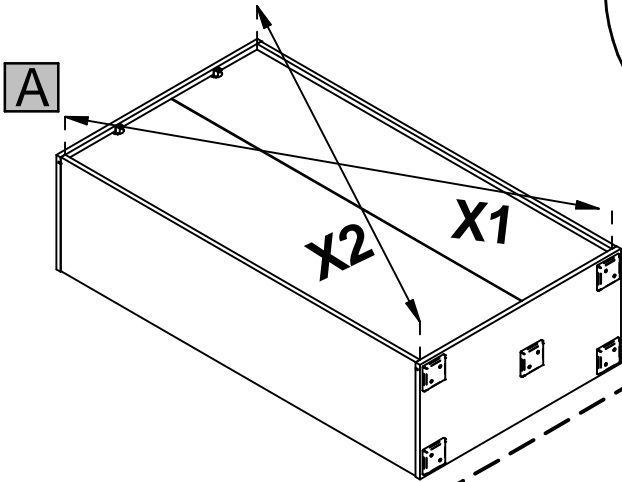

X1=X2

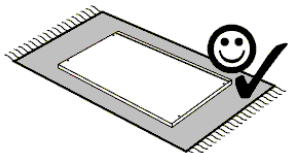
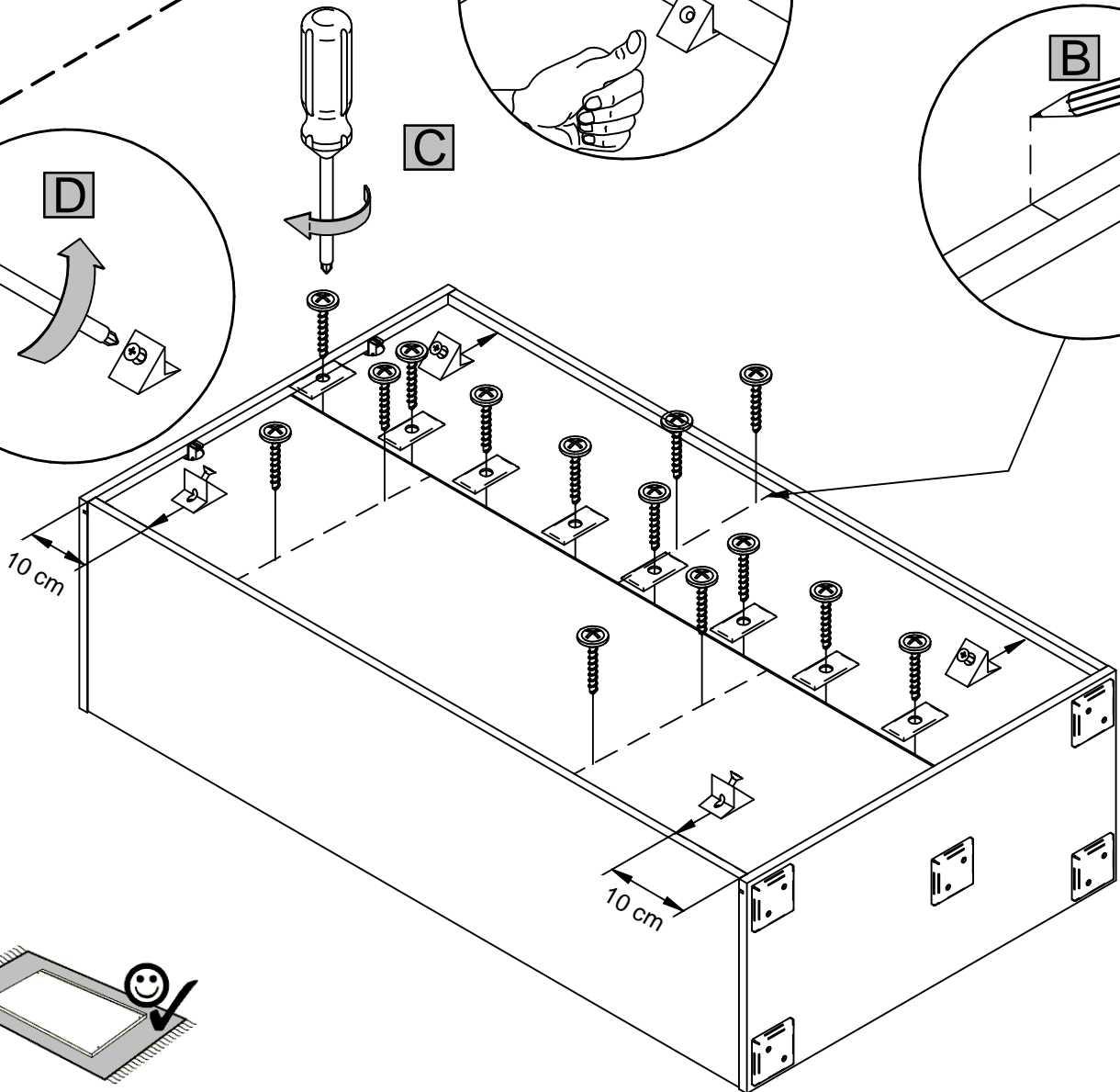

C



11.

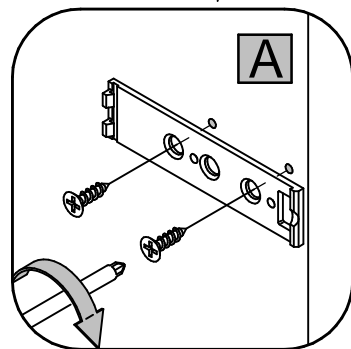
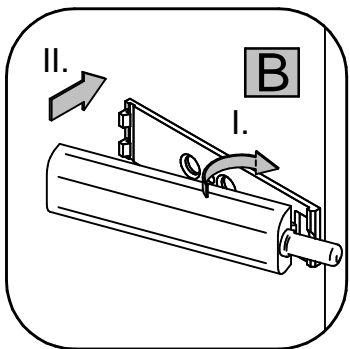
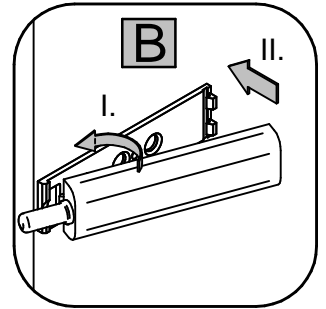
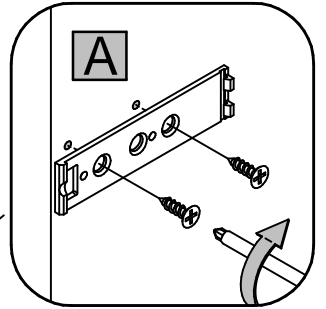
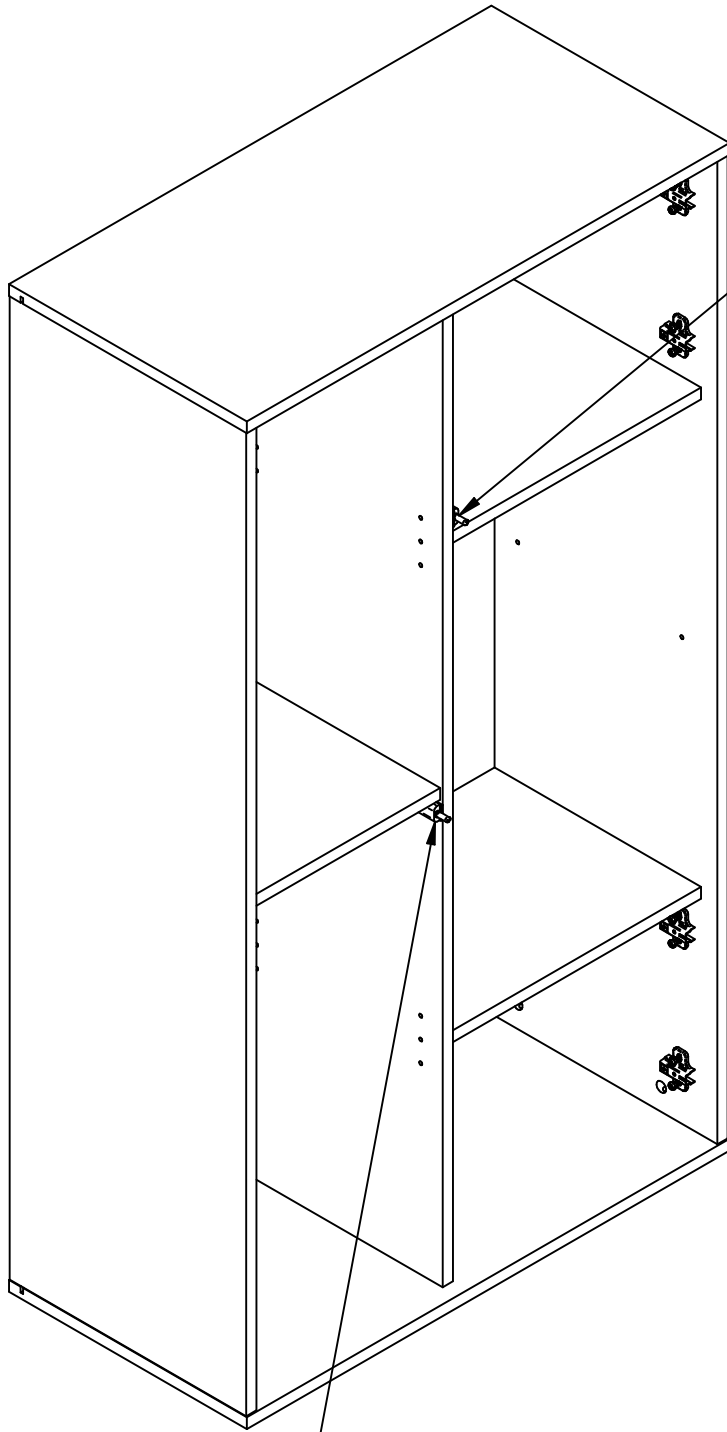

BT50496	MM1046	BT50244.xxx
		
x2	x4	x24

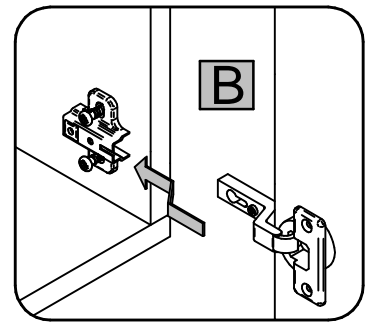
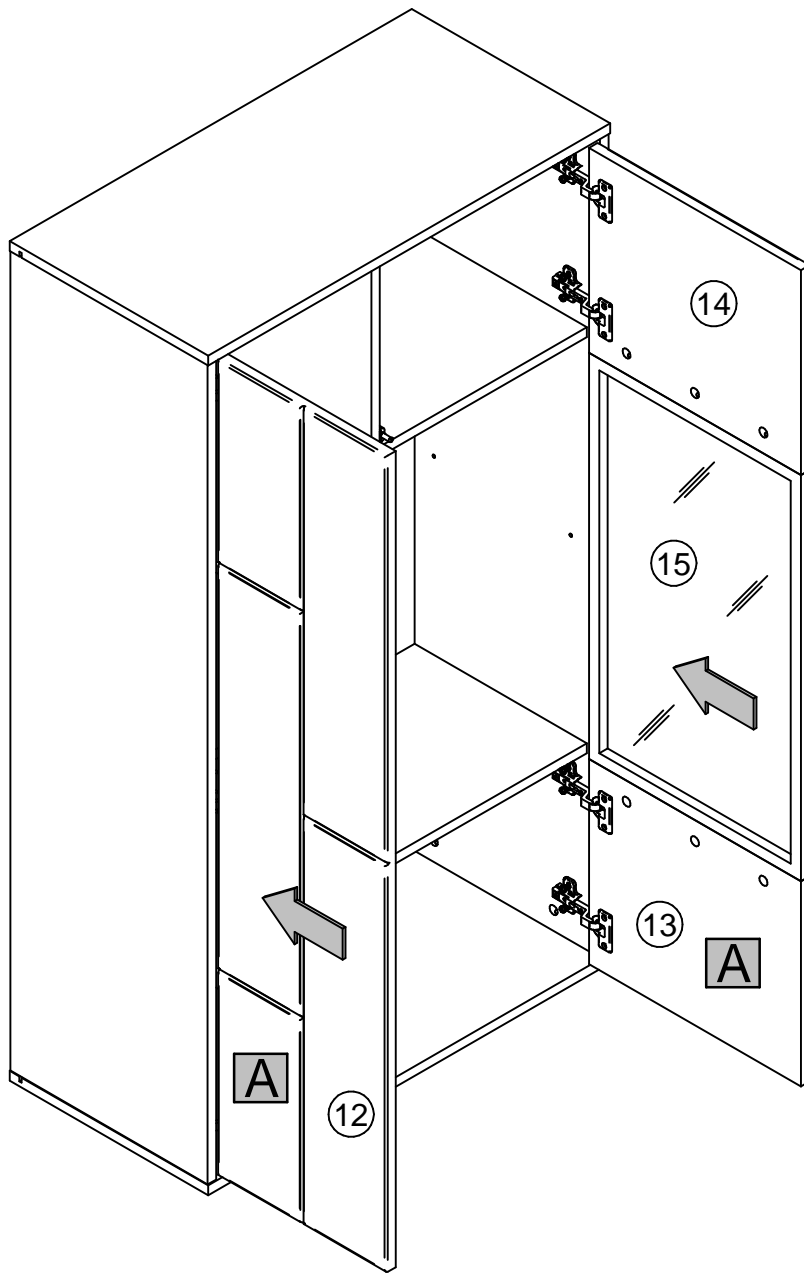

12.



13.

BT1005.xx	BT50581
	
x8	x4

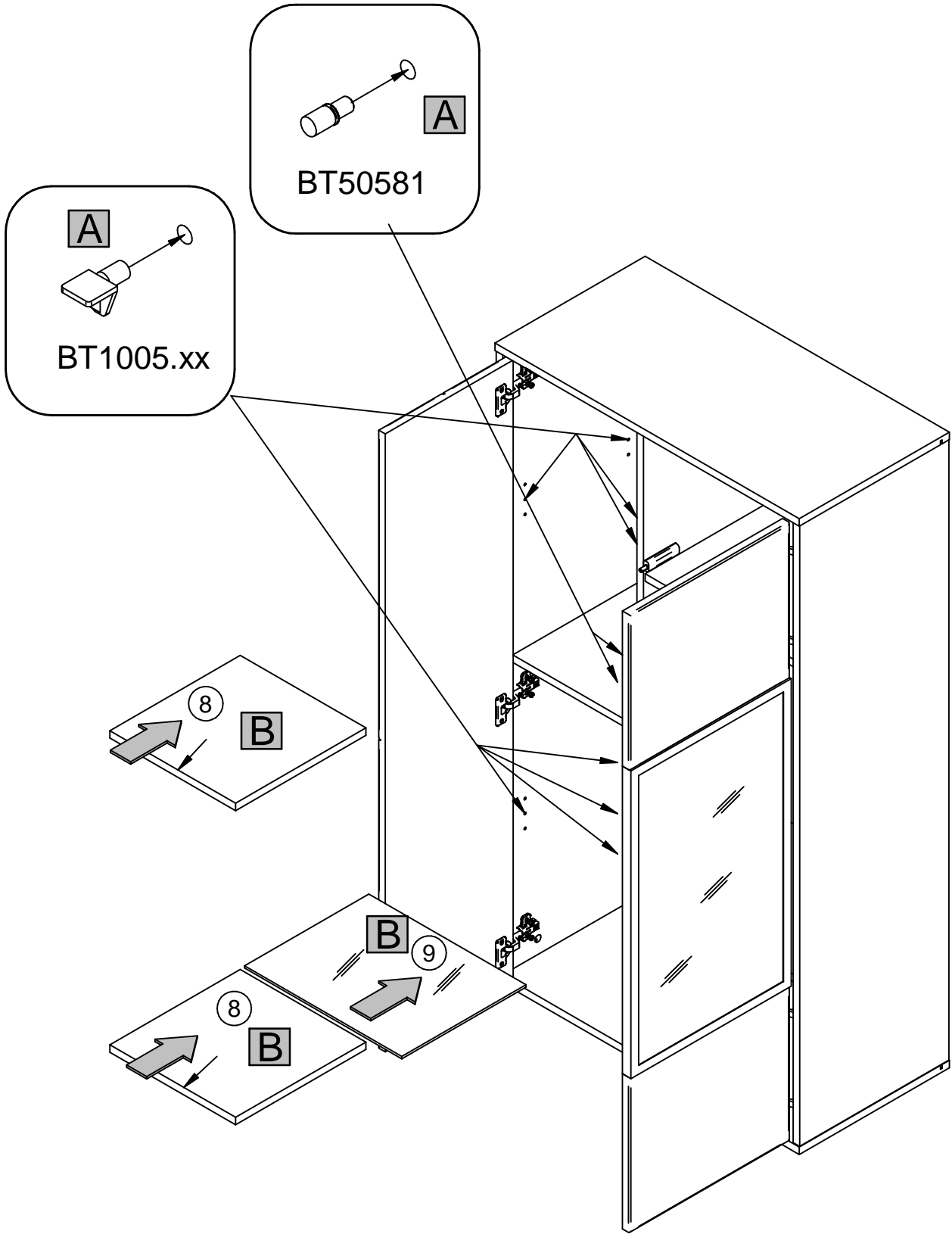



Due to the wide diversity of wall or partition types, we cannot provide you with suitable attachment fixtures. To determine which attachment fixtures to use, you will need to identify the types of wall to which you will be fixing this product. Here are some examples of attachment fixtures recommended for:

BLIND WALLS		STUDDED WALLS		
"FISCHER" Nylon plug	Metal Wall plug	Nylon winged Wall plug	Metal expansion plug	"MOLLY" plug

Use a drill bit that is compatible in size with the hardware used and the type of wall.



Da es eine große Vielfalt an Arten von Wänden oder Trennwänden gibt, können wir Ihnen leider keine Wanddübel zur Verfügung stellen. Bitte prüfen Sie die Eigenschaft der Wand, an der Sie das Möbelstück befestigen wollen, um den dafür passenden Wanddübel zu ermitteln. Ziehen sie ggf. eine Fachkraft zurate. Hier einige Beispiele für Wände und dafür passende Dübel:

Massivwände		Hohlwände		
Kunststoffdübel	Metall Wanddübel	Hohlraum Kunststoffdübel	Hohlraum Metalldübel	Hohlraumdübel "Molly"

Verwenden Sie einen an die Wandbeschaffenheit und Dübelgröße angepassten Bohrer.



Il existe une grande diversité de types de murs ou cloisons, c'est la raison pour laquelle nous ne pouvons vous fournir le type exacte de fixation. Il est nécessaire d'identifier le type de paroi à laquelle vous allez fixer ce produit afin de vous procurer les fixations appropriées. Voici quelques exemples de fixation conseillées pour:

LES MURS PLEINS		LES CLOISONS CREUSES		
Cheville nylon "Fischer"	Cheville d'ancrage metal	Cheville d'ancrage a ailettes en nylon	Cheville metallique a expansion	Cheville "Molly"

Utiliser une taille de forêt adaptée à la quincaillerie utilisée et au type de mur.



14.

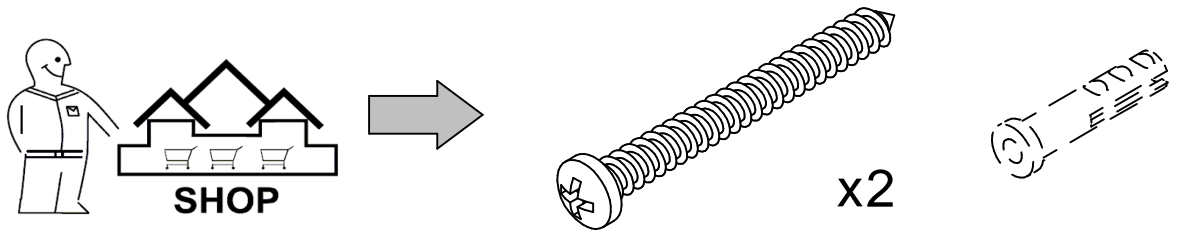

15.

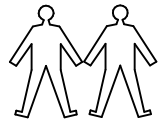
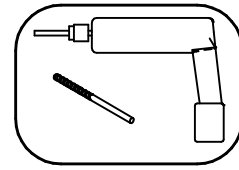
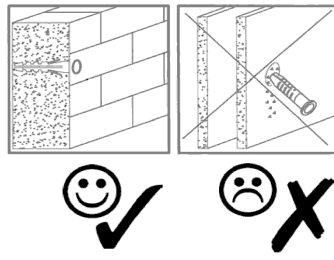
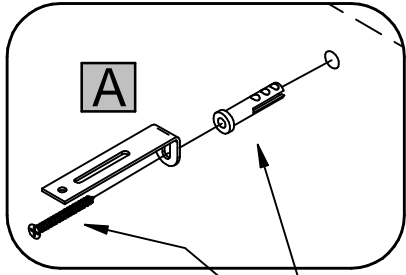

D

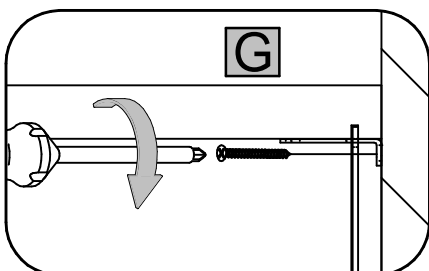
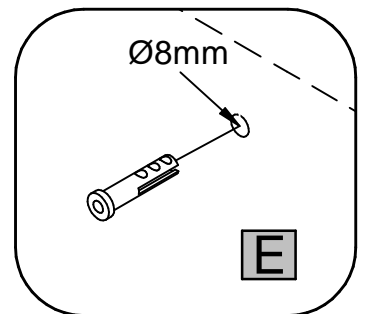
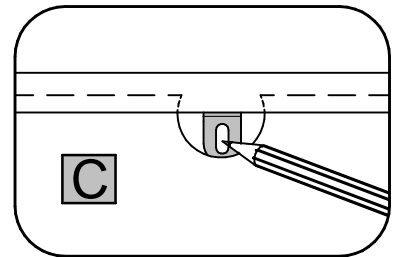
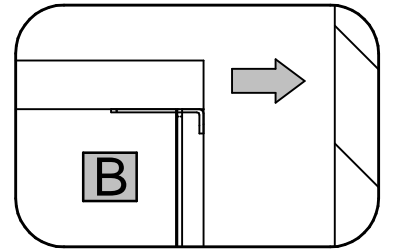
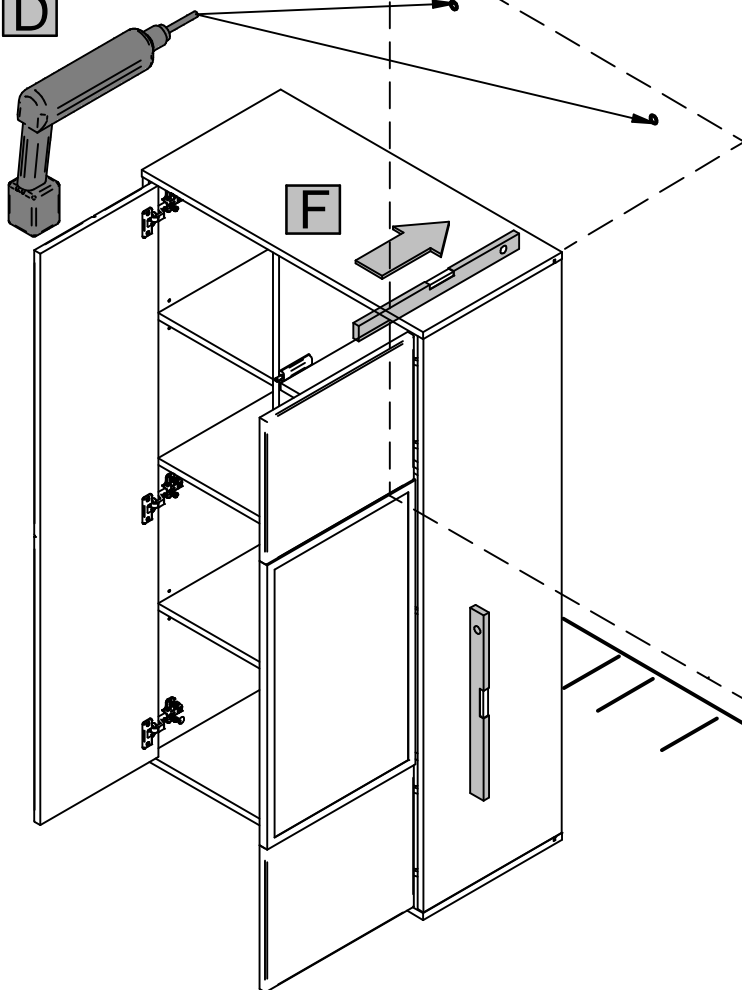

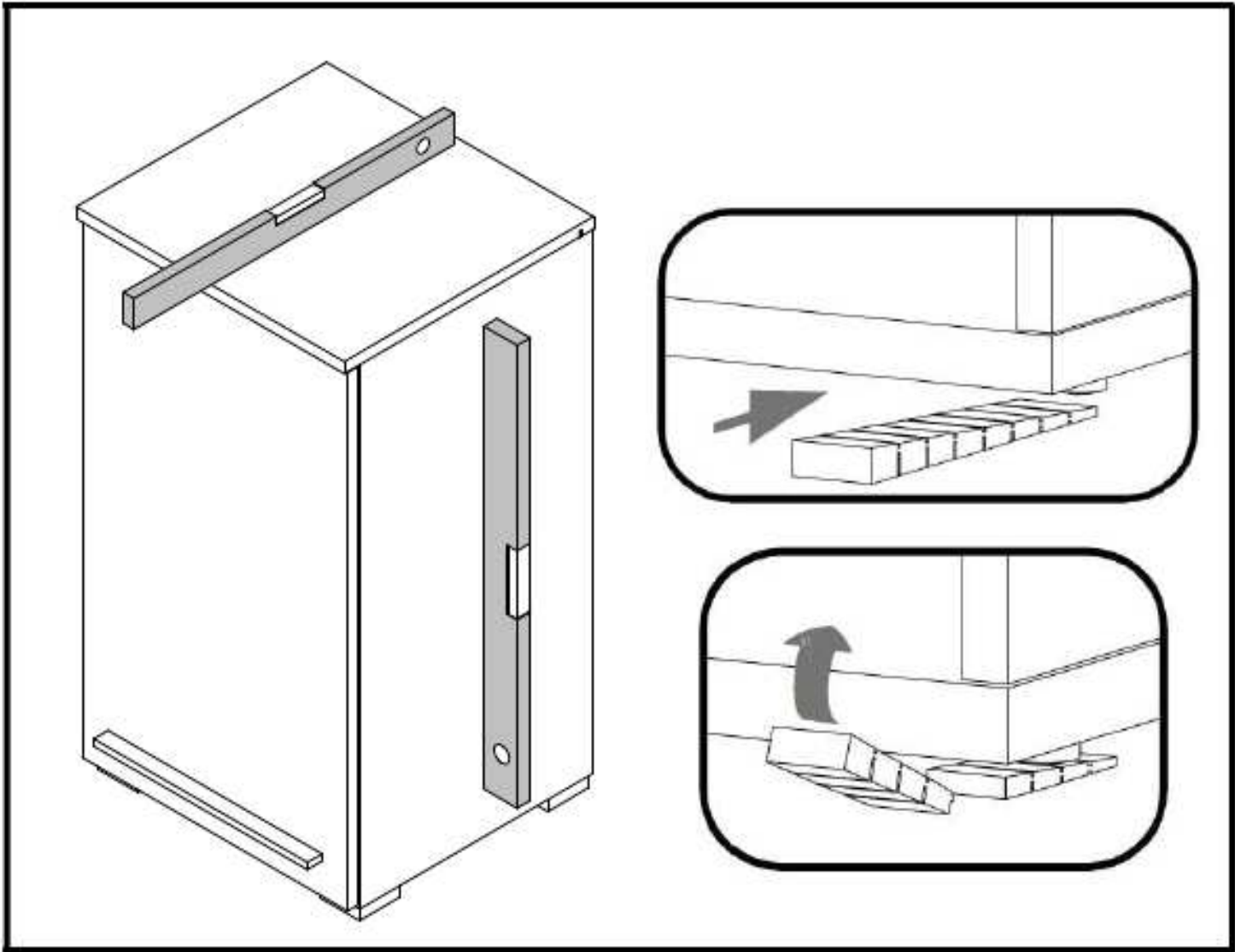
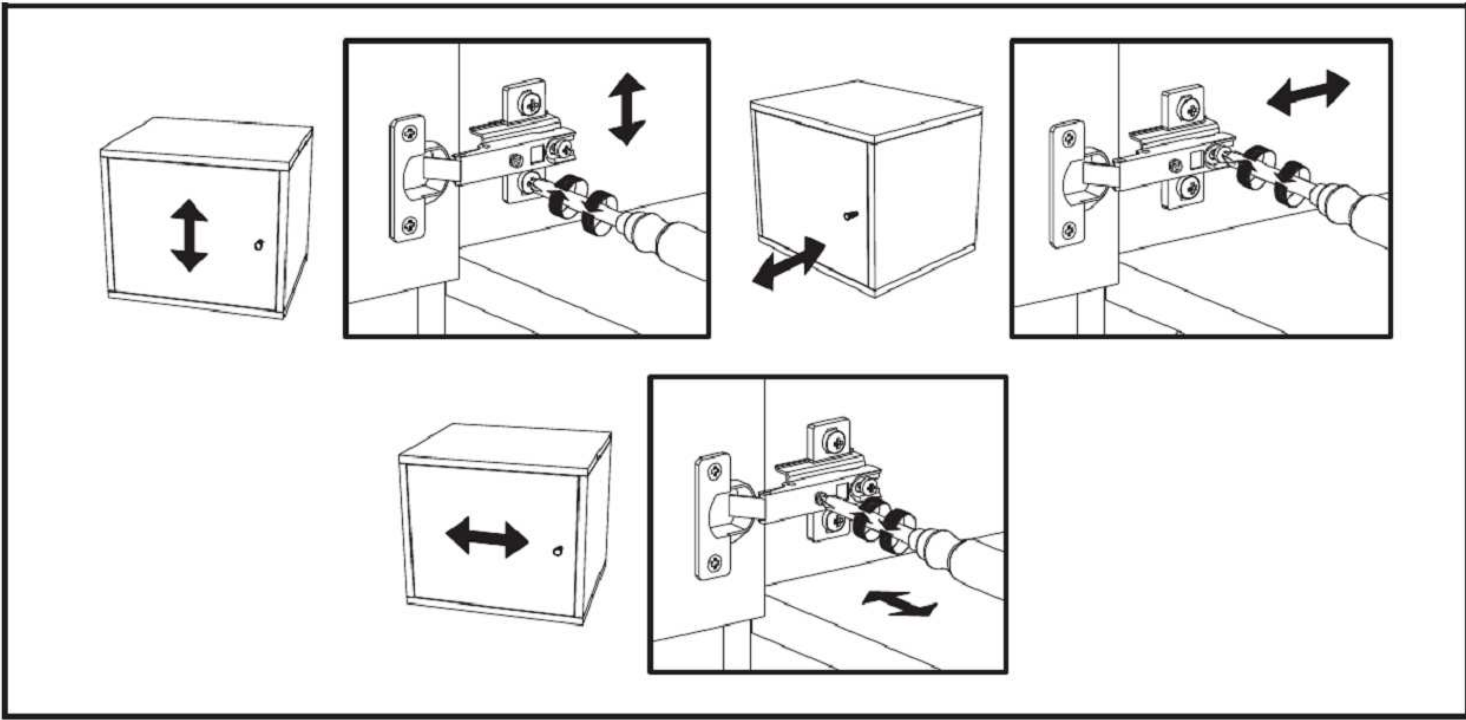

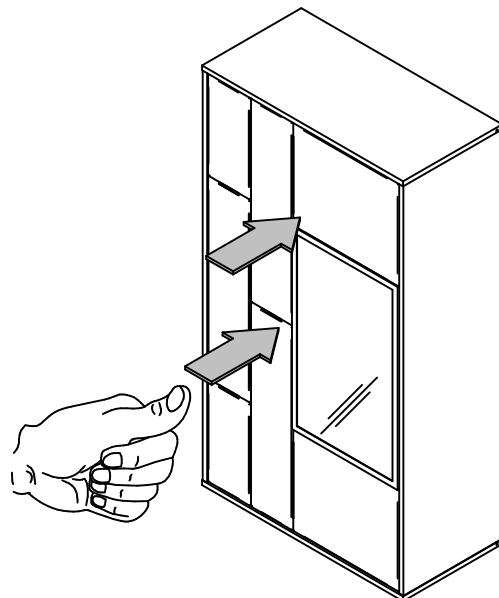
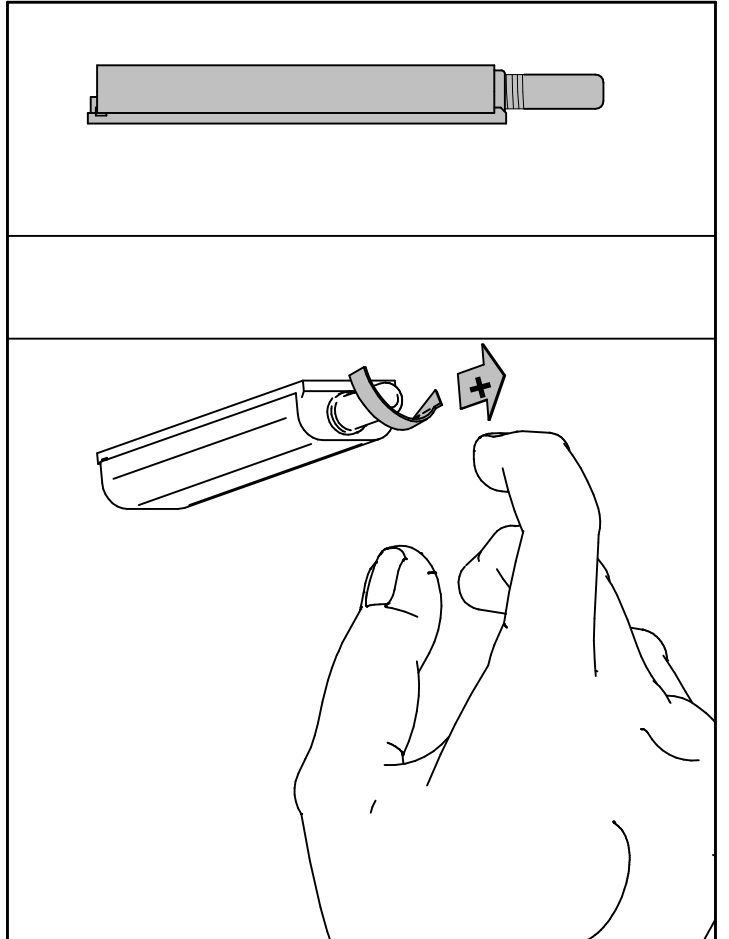
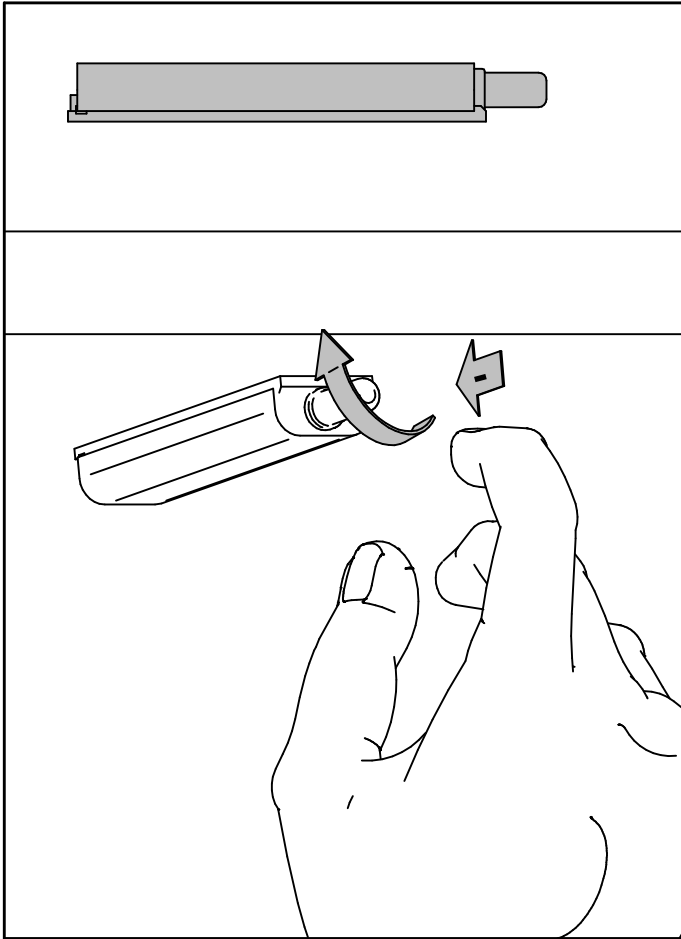
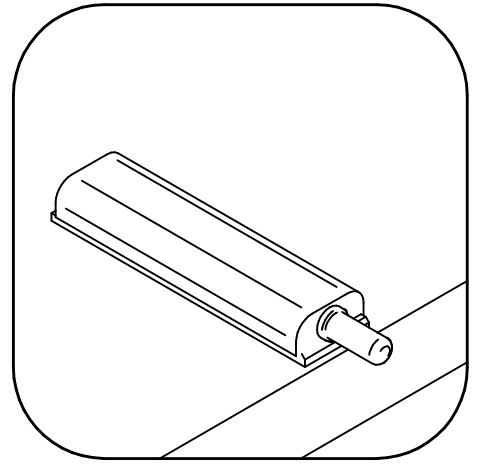
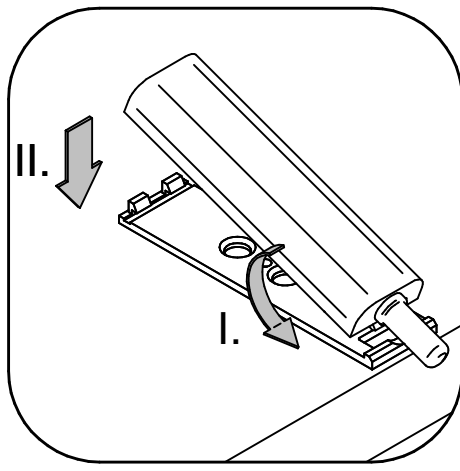
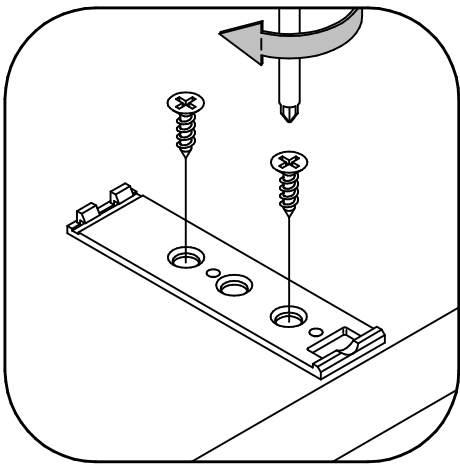

Modellname / Model name / Nom du modèle /  
 Nome modello / Název modelu / Modelnaam / Ime modela  
 Numéro Modello / Modell neve / Nombre del modelo /  
 Názov modelu / Ime modela / Denumire model /  
 Nome do modelo

**Sole**

Modellnummer / Number / Numéro du modèle  
 Numero / modello /  
 Číslo modelu / Modell száma / Eíslo modelu  
 Stevilka modela / Număr model

**3153WA - Weiss / Artisan**

Type / Tipo / Tipus / Typ / Tip

**01**

Service für Beschlagteile

**D** Sollte Ihnen ein Beschlagteil fehlen, wenden Sie sich bitte mit dieser Servicekarte direkt an ihr Möbelhaus.

Service for fittings.

**GB** If you are missing a fitting part, please contact your furniture store directly with this service card.

Servis armatur.

**CZ** Pokud vám chybí montážní díl, obraťte se přímo na prodejce nábytku pomocí této servisní karty.

Service de montage.

**F** Si vous manquez une pièce appropriée, contactez directement votre magasin de meuble avec cette carte de service.

Servizio per raccordi.

**I** Se manca una parte di montaggio, contatta direttamente il tuo negozio di mobili con questa scheda di servizio.

Servicio de accesorios.

**ES** Si le falta una pieza de montaje, por favor contacte a su tienda de muebles directamente con esta tarjeta de servicio.

Service voor fittingen.

**NL** Als u een passend onderdeel mist, neem dan contact op met uw meubelwinkel met deze servicekaart.

Servis czesci montazowych.

**PL** Jeżeli brakuje części koniecznych do montażu, prosimy o kontakt ze sklepem meblarskim bezpośrednio z tą kartą serwisową.

Servis za armature.

**HR** Ako vam nedostaje dio za ugradnju, obratite se svojoj trgovini namještajem izravno s ovom servisnom karticom.

Szerviz szerelvényekhez.

**HU** Ha hiányzik egy illeszkedő rész, kérjük, forduljon bútor üzlethez közvetlenül ezzel a szervizzel.

Servis pre armatúry.

**SK** Ak vám chýba montážna časť, obráťte sa priamo na tento obchod s nábytkom prostredníctvom tejto servisnej karty.

Servis za opremo.

**SLO** Če manjkajte ustrezen del, se obrnite na prodajalno pohištva neposredno s to servisno kartico.









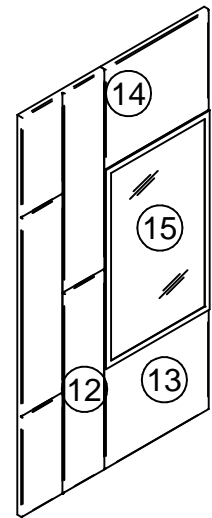
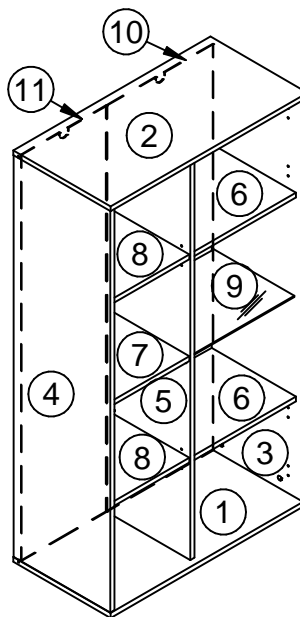







Service pentru armaturi.

**RO** Dacă vă lipsesc o piesă de montaj, vă rugăm să contactați magazinul de mobilier direct cu acest card de service.

Serviço de montagem.

**PT** Se você está faltando uma peça apropriada, entre em contato com sua loja de móveis diretamente com este cartão de serviço.



BT1016  x30	MM1016  x24	MM1121  x24	BT1142  x4	BT50101  x8	MM1202  x14	BT50094  x7	BT1304  x7
MM1046  x22	BT50496  x2	BT50238  x5	MM50051  x10	BT50581  x4	BT1121  x2	BT50244.xxx  x30	
BT1005.xx  x8	MM50453  x6						

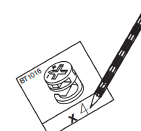
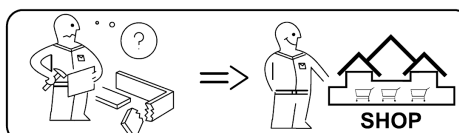

29.01.2025