

**D-** Montageanleitung **GB-** Assembly instructions **F-** Instructions de montage **PL-** Instrukcja montażu  
**RU-** Инструкция по монтажу **NL-** Montagehandleiding **TR-** Montaj talimatı **RO-** Instrucțiuni de montaj  
**IT-** Istruzioni per il montaggio **SK-** Návod na montáž **CZ-** Návod k montáži **HU-** Szerelési útmutató  
**HR-** Uputstvo za montažu **SI-** Navodila za montažo



- D Allgemeiner Sicherheitshinweis:**  
Nicht mehr benötigte Verpackungs-Materialien und Kleinteile von Kindern fernhalten!
- GB General safety instructions:**  
Package material you do not need any more take far away from children.
- F Consigne de sécurité:**  
Ecarter les matériaux d'emballage et petites pièces inutiles de la portée des enfants.
- PL Ogólne zasady bezpieczeństwa:**  
Nie potrzebne opakowania i małe części chronić przed dziećmi!
- RU Общие указания по безопасности:**  
Неиспользуемые упаковочные материалы и мелкие детали следует хранить в недоступном для детей месте!
- NL Algemene veiligheidsinstructie:**  
Verpakkingsmaterialen die u niet meer nodig heeft en kleine onderdelen uit de buurt van kinderen houden!
- TR Genel güvenlik uyarısı:**  
Kullanılmayan ambalaj malzemeleri ve küçük parçaları çocuklardan uzak tutun!
- RO Indicație generală de siguranță:**  
Ambalajele care nu mai sunt necesare și piesele de mici dimensiuni nu vor fi lăsate la îndemâna copiilor!
- IT Indicazioni generali per la sicurezza:**  
Tenere lontano da bambini materiali di imballaggio non più necessari e minuterie!
- SK Všeobecné bezpečnostné upozornenie:**  
Nepotrebný baliaci materiál a malé diely uchovávajte mimo dosahu detí!
- CZ Všeobecné bezpečnostní upozornění:**  
Obalové materiály a malé díly, které už nepotřebujete, udržujte mimo dosah dětí!
- HU Általános biztonsági tudnivaló:**  
Ha már nincs szüksége a csomagolóanyagokra és apró darabokra, tegye őket olyan helyre, ahol nem férhetnek hozzá gyermekek!
- HR Opće sigurnosne upute:**  
Materijal od pakiranja koji Vam više nije potreban maknuti dalje od djece!
- SI Splošna varnostna navodila:**  
Embalažni material, ki ga ne potrebujete več, in majhne dele hranite izven dosega otrok!

Modell, model, modele, Model, Модель,  
Model, Model, Model, Modello, Model:

**TIMOUR**

Typ, type, type, Тип, Тип, Type, Tip,  
Tipo, Tipus:

T20 - Vitrine R

Art. Nummer: 01820017-06

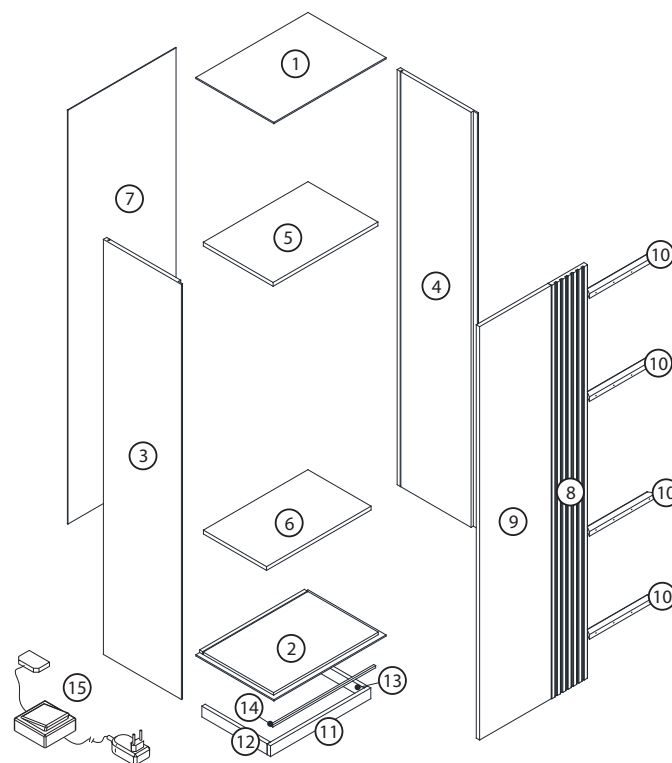
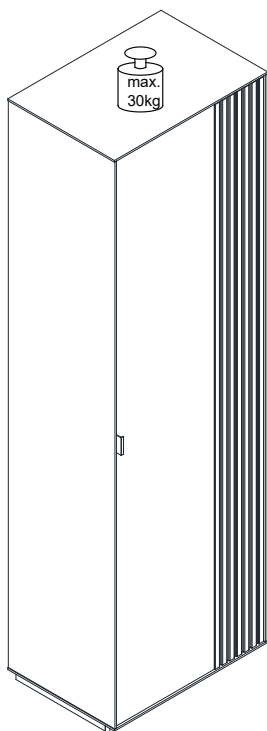

Montage mit, assembly by, Montage par, Montować z, Сборка с помощью,  
Montage met, Montaj aleti, Montaj cu, Montaggio con, Montáž s, Montáž s,  
Szerelés ezzel, za montažu potrebno, Montaža z:

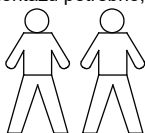

Werkzeug, tools, outils, Narzędzia, Инструмент, Gereedschap, Alet, Scule,  
Utensile, Nářadie, Nářadí, Szerszám, Alat, Orodjem:

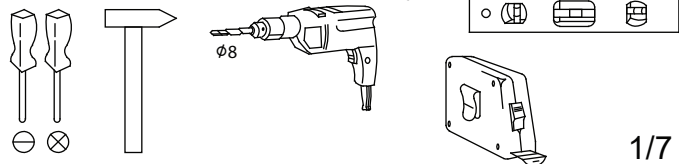

**Servicekarte / servicecard / carte de service / Karta gwarancyjna / Сервисная карточка / Servicekaart / Servis karti/ Carte de service/ Scheda Servizio assistenza/ Servisná karta/ Servisní karta/ Szerviz kártya/Servis karta / Servisne informacije/**

Modell, model, modele, Model, Модель, Model, Model, Model, Modello, Model: T20 - Vitrine R

- D** Bitte füllen Sie die Servicekarte sorgfältig aus und markieren Sie bitte das betreffende Teil, damit Sie alle nötigen Daten bei Ihrer Ersatzteilbestellung zur Hand haben. Die Telefon-Service Nummer finden Sie auf Ihrer Rechnung oder in unseren Werbemitteln.
- GB** Please fill out this servicecard accurate and specify the spare part number by marking. The Hotline-Number you find in Katalog or publicity.
- F** Merci de remplir la carte de service soigneusement et de codier la pièce concernée afin de disposer des données nécessaires a la commande des pièces de rechange. Vous trouvez le numéro de téléphone de notre service commercial sur votre confirmation de commande ou sur la facture.
- PL** W celu dostarczenia wszystkich informacji dla zamówienia części zamiennych, prosimy rzetelnie wypełnić kartę gwarancyjną i wskazać na karcie uszkodzoną część. Telefon serwisu znajdują Państwo na rachunku lub na załączonej ulocie.
- RU** Пожалуйста, внимательно заполните Сервисную карточку и отметьте соответствующую деталь для того, чтобы иметь всю необходимую информацию при заказе запасных частей. Сервисный номер телефона указан на Вашем счёте или в наших рекламных материалах.
- NL** De servicekaart zorgvuldig invullen en het betreffende onderdeel markeren, opdat u bij de bestelling van het vervangende onderdeel de noodzakelijke gegevens bij de hand heeft. Het servicetelefoonnummer vindt u op uw factuur of in ons reclamemateriaal.
- TR** Yedek parça siparişiniz sırasında gerekli tüm bilgilere sahip olmanız için, lütfen servis kartınızı dikkatli bir şekilde doldurun ve ilgili parçayı işaretleyin. Telefon-servis numarasını faturanız üzerinde ya da reklamlarımızda bulabilirsiniz.
- RO** Vă rugăm să completați cu atenție cartea de service și să marcați piesa respectivă, astfel încât să aveți la îndemână toate informațiile în momentul comandării piesei de schimb. Numărul de telefon pentru asistență se găsește pe factura dumneavoastră sau în materialele publicitare.
- IT** Vogliate compilare con cura la scheda per il Servizio assistenza e di evidenziare la parte interessata, al fine di avere a portata di mano tutti i dati necessari per l'ordine di parti di ricambio. Il numero di telefono del Servizio assistenza e riportato sulla vostra fattura o sul nostro materiale pubblicitario.
- SK** Servisnú kartu vyplňte prosím starostlivo a označte príslušný diel, aby ste pri objednávke náhradného dielu mali všetky potrebné údaje. Servisné telefónne číslo nájdete na potvrdenke alebo na našich reklamných prostriedkoch.
- CZ** Vyplňte prosím pečlivě servisní kartu a označte příslušný díl, abyste měli připravené všechny potřebné údaje při své objednávce náhradních dílů. Telefonní číslo servisu najdete na své faktuře nebo v našich reklamních materiálech.
- HU** Kérjük, töltse ki figyelmesen a szerviz kártyát, és jelölje be a megfelelő részt, hogy rendelkezésre álljanak a pótalkatrészek megrendeléséhez szükséges adatok. A szerviz telefonszáma a számlán, vagy reklámanyagainkban található.
- HR** Prilikom reklamacije koristiti točno ove brojeve i oznake dijelova koji su naznačeni u servis karti. Info broj tel.pronaći u katalogu ili javnosti.
- SI** Prosimo, da natančno izpolnite obrazec s servisnimi informacijami in označite zadevni del. Tako boste imeli vse potrebne podatke za naročilo nadomestnega dela pri roki. Telefonsko številko servisnega centra najdete na računu ali v našem promocijskem materialu.

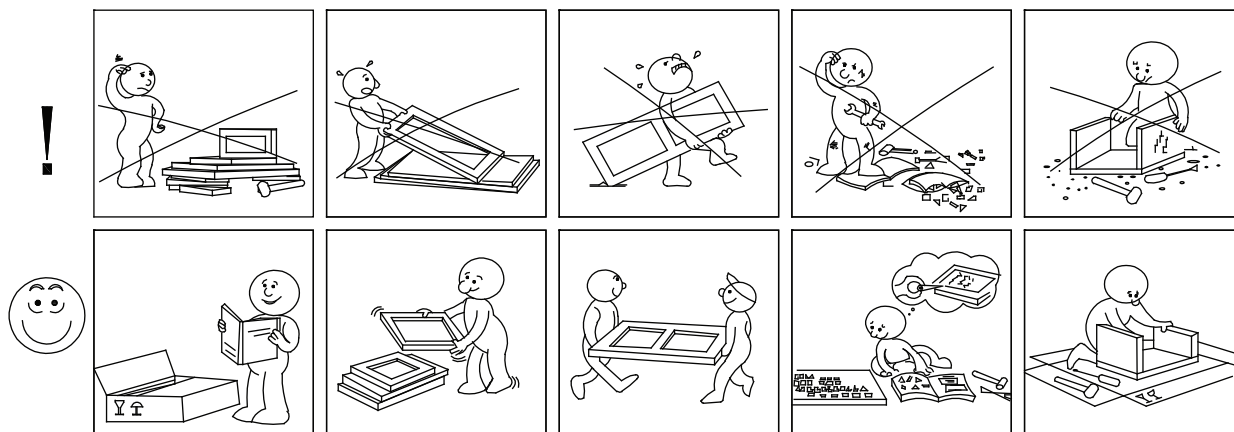
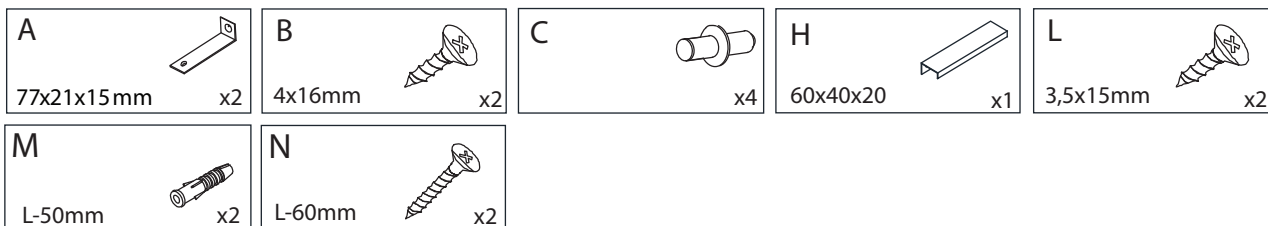

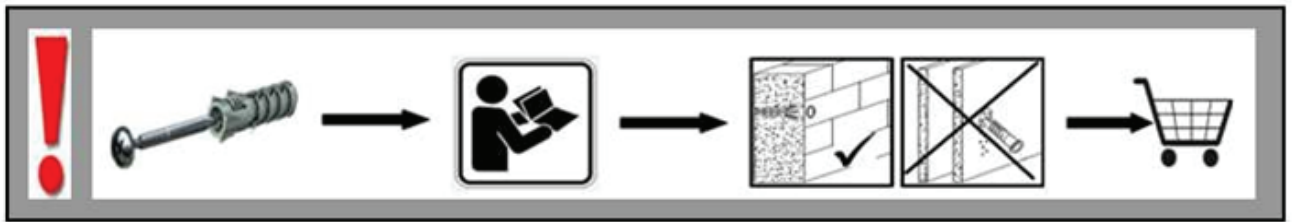

## DE

### **Achtung! Die Wandbeschaffenheit ist vor der Montage unbedingt zu prüfen.**

Die beigelegten Universaldübel sind ausschließlich nur zur Verwendung für festes Mauerwerk wie Beton/Ziegel. Die Mauerdübel dürfen nicht bei Mauerwerk wie Hohlraumziegel, Leichtbausteinen, Gipskartonplatte oder anderer Rahmenbauweise verwendet werden.

Bei diesen Mauerwerken sind gegebenenfalls Spezialdübel zu verwenden! Diese sind in einem Fachgeschäft (Baumarkt) erhältlich.

**Bei Nichteinhaltung wird seitens Produzenten/Händler und Importeur keine Haftung übernommen**

## EN

### **Caution! The wall must be examined before assembly**

The included universal wall plugs are only suitable for using in firm masonry such as concrete block or brick.

Do not using the wall plugs masonry such as hollow brick, lightweight block, surfaces such as gypsum plasterboard or other framing systems.

If applicable, particular wall plugs must be used! These are available at a specialised store (hardware store). **In case of non-compliance, the manufacturer/retailer or importer do not assume liability.**

## S

### **OBS! Väggens sammansättning ska absolut kontrolleras innan montering.**

De bifogade pluggarna får endast användas för stabila och fasta väggar, som t.ex. betong/tegel.

De får absolut inte användas för kavitet tegel, väggar ur fonolit, gipsskivor eller dylikt.

För dessa väggar måste det användas speciella pluggar, som finns att köpa i specialiserad handel (byggmarknad). **Varken tillverkare, handlare eller importör övertar ansvar, om dessa anvisningar inte följs.**

## SLO

### **Pozor! Pred montažo preverite stanje stene.**

Priloženi univerzalni mozniki so izključno samo za uporabo na čvrstem zidovju, kot sta beton in opeka.

Stenski mozniki se ne smejo uporabljati pri zidovju kot so votlino opeke, zidaki za lahko gradnjo, mavčne plošče ali druge okvirne gradnje.

Pri teh zidovjih morate v danih primerih uporabljati posebne moznike. Ti so na voljo v specializiranih trgovinah (trgovinah z gradbenim materialom)

**Pri neupoštevanju se s strani proizvajalca/trgovca in uvoznika ne prevzame jamstvo**

## CZ

### **Upozornění! Před montáží je nutné zkontrolovat stav stěny.**

Příložené univerzální hmoždinky jsou určeny pouze k použití pro pevné zdivo jako beton/cihly.

Hmoždinky do zdi se nesmí používat u dutinová cihla, zdiva jako pórovitý stavební kámen, sádrokartónová deska nebo jiný měkký materiál.

U těchto zdiv jsou nutné použít speciální hmoždinky! Jsou k dostání v speciálních prodejnách se stavebním materiálem. **Při nedodržení těchto pokynů výrobce/prodejce a dovozce neručí za způsobené škody**

## HR

### **Pažnja! Prije montaže obvezno provjerite svojstvo zida.**

Priložene univerzalne tiplje namijenjene su isključivo za masivne zidove od betona/opeke.

Tiplje za masivne zidove ne smiju se koristiti za zidove kao npr šupljina opeka laki sastavni elementi, gips-kartonske ploče ili drugi modularni načini gradnje.

Za te zidove potrebne su eventualno specijalne tiplje! Iste su dostupne u specijaliziranim trgovinama građevinskim materijalom.

**U slučaju nepridržavanja prethodno navedenih napomena, proizvođač/trgovac i uvoznik ne preuzimaju odgovornost!**

## HU

### **Vigyázat! Szerelés előtt a falfelületet feltétlenül vizsgálja meg.**

A mellékelt univerzális tiplik kizárólag stabil falazathoz használható mint például beton/tégla.

A fal tiplik nem használható könnyű építőkövekhez, üreg tégla, gipszkarton lapokhoz vagy más favázás építményekhez. Ezekhez a falfelületekhez csak speciális tiplik használhatóak, melyek szaküzletekben (barkácsáruházakban) beszerezhetőek.

**Fentiek figyelmen kívül hagyása esetén a gyártó/kereskedő vagy forgalmazó nem vállal felelősséget**

## SK

### **Upozornenie! Pevnosť steny sa musí pred montážou bezpodmienečne skontrolovať**

Univerzálne hmoždenky, ktoré sú obsiahnuté v balení, používajte jedine pre pevné murivo ako je betón/tehla.

Hmoždenky sa nesmú používať v prípade ľahkého staveného muriva, dutina tehla, u sádrokartónových dosiek alebo iných konštrukcií rámu.

U týchto murív je nutné použiť špeciálne hmoždenky! Tieto je možné dostať v špeciálnych predajniach so stavebným materiálom (stavebniny).

**Pri nedodržaní pokynov nepreberajú výrobcovia/predajci a dodávatelia zodpovednosť za vzniknut**

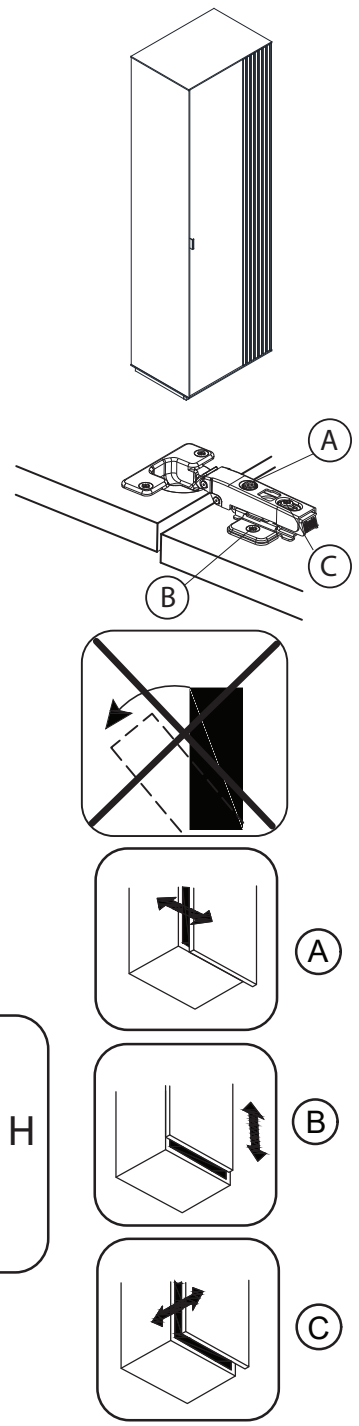
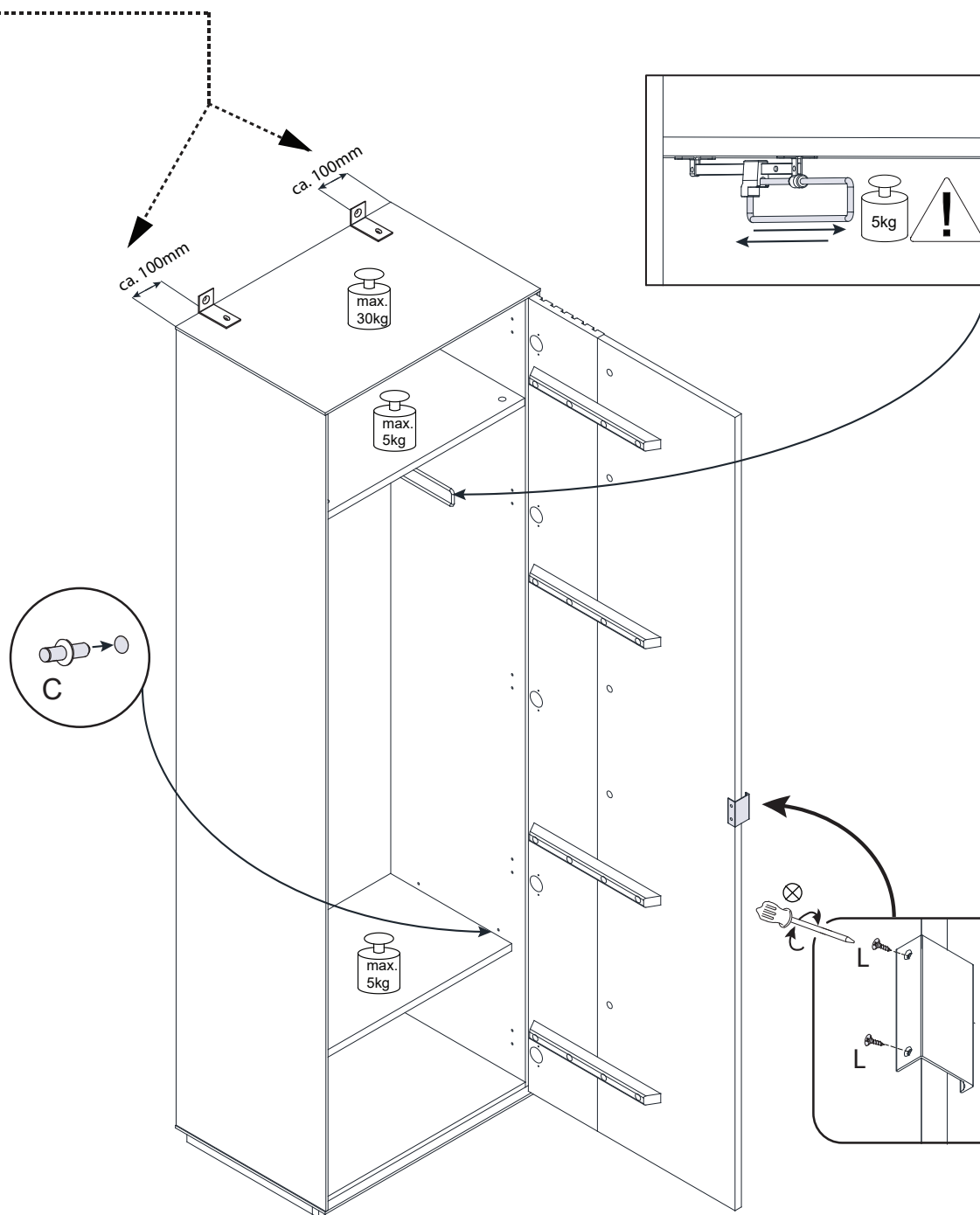
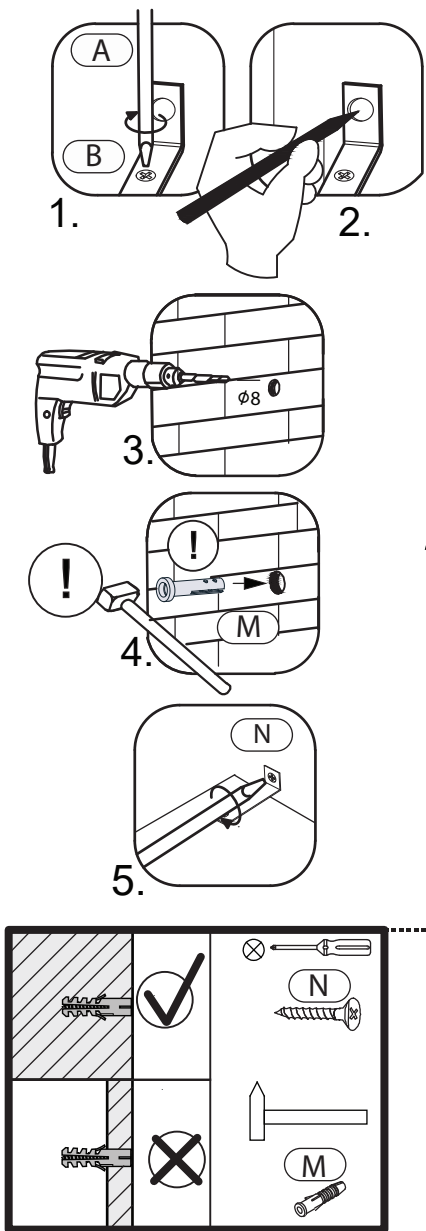

# BELEUCHTUNG

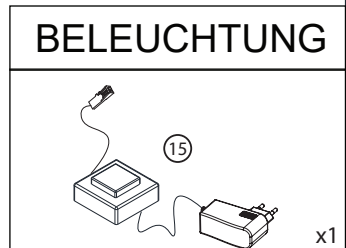
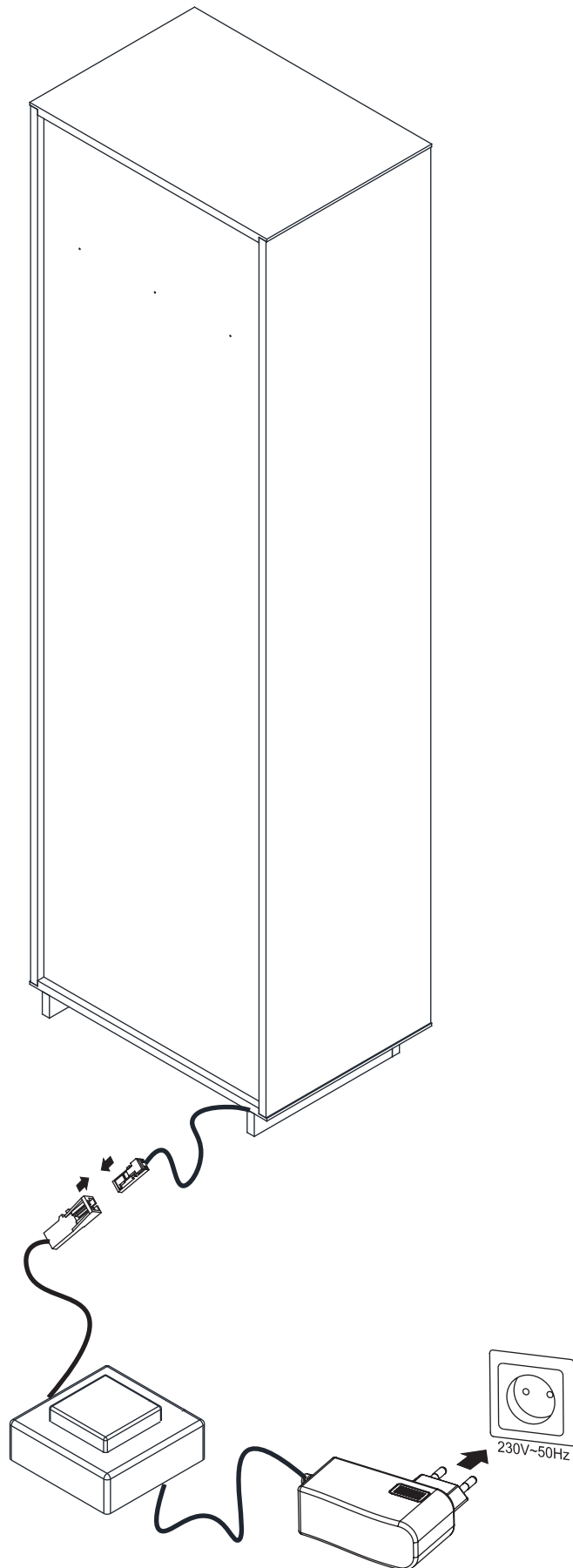

<p><b>D - Allgemein</b> Achten Sie bitte auf regelmäßige Lüftung der Räume. Zu trockene Luft fordert das Verziehen der Hölzer. Feuchtigkeit und Nässe sofort mit einem trockenen Tuch abwischen. Alle Oberflächen bitte nicht mit scharfen oder spitzen Gegenständen beschädigen. Oberflächen bitte nicht mit scharfen Putz- oder Reinigungsmitteln behandeln. Zur Reinigung der Oberflächen verwenden Sie bitte lediglich ein angefeuchtetes Tuch. Dieses Produkt ist nur für den Einsatz im Privathaushalt konzipiert!</p> <p><b>Massivholz</b> Feine Äste, Verwachsungen und kleine Risse sind naturbedingt und kein Reklamationsgrund. Farbdifferenzen und verschiedene Maserungsverläufe zeugen von der Echtheit des Holzes und sind kein qualitativer Mangel.</p> <p><b>Lackierte Oberflächen</b> Gegenstände bitte nicht ohne geeigneten Untersetzer auf den Oberflächen abstellen. Eventuell sichtbare Polier- und Schleifspuren sind produktionsbedingt und stellen keinen qualitativen Mangel dar.</p> <p><b>Geölte und gewachste Oberflächen</b> Vermeiden Sie bitte Staunässe auf der Oberfläche und entfernen Sie Getränkereste sofort. Bitte beachten sie, dass dieses Möbel bei normalem Gebrauch nur für ca. 6 Monate geschützt ist und danach nachbehandelt werden muss. Äußerst hart beanspruchte Oberflächen wie die von Tischen benötigen die Nachbehandlung wesentlich früher und öfter, geeignetes Pflegematerial erhalten Sie im Fachhandel. Bitte beachten Sie, dass eingefärbte Flüssigkeiten oder Reiniger den Ausdruck des Holzes nachhaltig verändern.</p> <p><b>Glasoberflächen</b> Bitte keine heißen oder sehr kalten Gegenstände ohne geeignete Untersetzer auf die Glasfläche stellen. Bitte die Glasfläche nicht als Arbeitsfläche zum Schneiden oder ähnliches benutzen.</p> <p><b>Polster und Kissen</b> Bekleidungstextilien können unter Umständen abfärben. Nicht farbechte Bekleidung kann auf den Bezugsstoff abfärben. Dies gilt besonders bei hellen Bezugsstoffen. Ein Abfärben von Bekleidungstextilien kann nicht als Reklamationsgrund der Bezugsstoffe von uns anerkannt werden.</p> <p><b>Metalloberflächen</b> Leicht sichtbare Spuren vom Schleifen unter der Beschichtung sind produktionsbedingt und kein qualitativer Mangel.</p>	<p><b>GB - General</b> please make sure that your rooms are ventilated regularly very dry or very humid air will support the warping of wooden products wipe off liquids and moist spots immediately with a soft and dry cloth prevent sharp and pointed objects from direct contact with the surface do not use washing powders or any other substances containing abrasives to clean the surface This product is designed only for use in private homes!</p> <p><b>Solid wood</b> Little knots, connations and little cracks in the wood are a typical natural characteristic of wood and not a reason for a claim. Differences in colour and grain are also typical for solid wood and not a qualitative defect.</p> <p><b>Lacquered surfaces</b> Please don't put any item without table mat on the surface, it could cause heavy scratches. Maybe visible polish marks are conditions of production and not a reason for a claim.</p> <p><b>Oiled and waxed surfaces</b> please take care of wetness on the surface and clean it at once care products should be applied no later than ca. 6 months for the first time. please notice! Oiled and Waxed products are wearing out through daily use. Heavily used surfaces, such as table tops, should be treated earlier. Do not forget to repeat this treatment in regular intervals, suitable care products you will get at your local specialist shop coloured liquids or soaps might smudge the wood</p> <p><b>Glass surfaces</b> Do not place very hot or very cold items on the glass surface(s) unless adequately thick table mats are used to prevent such items from coming into contact with the glass Do not use the glass as a chopping surface. Do not strike the glass with hard or pointed items use a damp cloth or leather with washing up liquid or soft soap to clean the surface</p> <p><b>upholstery and pillows</b> In way it could bet that clothes lose colour, especially dark one. Not colour-fast clothes can lose the colour on the fabric. This could happen especially with light coloured fabrics. This case is not a reason to claim the fabrics of our furniture.</p> <p><b>Metal Surfaces</b> Easy visible marks from grinding and polishing under the coating of the surface are conditions of production and not a reason for a claim.</p>
---	--

<p><b>F - Généralités</b> Veuillez à aérer régulièrement les pieces. Un air trop sec engendre la déformation du bois. Essayez immédiatement toute trace d'humidité ou d'eau. Veuillez ne pas endommager l'ensemble des surfaces avec un objet aiguisé ou pointu. Veuillez ne pas traiter les surfaces à l'aide de produits d'entretien ou nettoyage agressifs. Veuillez utiliser un chiffon légèrement humide pour nettoyer les surfaces. Ce produit n'est conçu uniquement pour une utilisation domestique !</p> <p><b>Bois massif</b> De petits no uds, difformités et fissures sont d'origine naturelle et ne peuvent faire l'objet d'une réclamation. Les différences de tons et les différents sens des veinures sont la garantie de l'authenticité du bois et ne constituent pas une atteinte a la qualité.</p> <p><b>Surfaces peintes</b> Veuillez prévoir un dessous-de-plat adapté pour les objets a déposer sur les surfaces. D'éventuelles traces de ponçage ou de polissage visibles sont liées a la fabrication et ne constituent pas une atteinte a la qualité.</p> <p><b>Surfaces cirées et huilées</b> Veuillez éviter que l'eau stagne sur la surface et enlevez immédiatement les traces de boisson. Veuillez prendre note que ces meubles ne sont protégés que pendant une durée de 6 mois dans le cadre d'une utilisation normale et qu'ensuite, ceux-ci doivent faire l'objet d'un nouveau traitement. Les surfaces particulièrement mises a l'épreuve telles que celles des tables, nécessitent ce nouveau traitement bien avant et plus souvent. Vous trouverez un produit d'entretien adapté dans le commerce spécialisé. Veuillez a ce que les liquides ou nettoyants teintés n'affectent pas le rendu du bois.</p> <p><b>Surfaces en verre</b> Veuillez prévoir un dessous-de-plat adapté pour les objets chauds ou tres froids a déposer sur les surfaces. Veuillez ne pas utiliser la surface en verre en tant que plan de travail pour découper, trancher, etc..</p> <p><b>Garniture et coussins</b> Les textiles de revêtement peuvent déteindre sous certaines conditions. Un revêtement qui n'est pas lavable en machine peut déteindre sur le tissu d'ameublement. Ceci, tout particulièrement lorsque les tissus d'ameublement sont clairs. Un décoloration de textiles de revêtement n'est pas considéré comme recevable en tant que raison invoquée pour une réclamation sur les tissus d'ameublement.</p> <p><b>Surfaces métalliques</b> Des traces légèrement visibles de ponçage sous le revêtement sont liées a la fabrication et ne constituent pas une atteinte a la qualité.</p>	<p><b>PL - Ogólne:</b> Proszę zwracać uwagę na regularne wietrzenie pomieszczeń Zbyt suche powietrze przyspiesza kurczenie się drewna Miejsca na których znajduje się woda (zawilgoconia, zachlapania) musza zostać natychmiast wytarte suchą szmatką Proszę nie rysować Sądnych powierzchni ostrymi narzędziami Powierzchni nie naleSy zczyścić silnymi środkami chemicznymi (Śrące środki do czyszczenia), gdyż mogą one zniszczyć czyszczone miejsce. Do czyszczenia powierzchni zaleca się wyłącznie uSycie wilgotnej szmatki Ten produkt jest przeznaczony wyłącznie do prywatnego uSytku</p> <p><b>Drewno masywne:</b> Male zmiany w drewnie, rozmycie koloru i niewielkie pęknięcia są uwarunkowane naturą drewna i nie są podstawą do reklamacji. Zmiany w kolorze i roSne rozmieszczenie stójów są dowodem na prawdziwość drewna i nie są podstawą do reklamacji.</p> <p><b>Powierzchnie lakierowane:</b> Nie naleSy kłaść przedmiotów na lakierowaną powierzchnię bez odpowiedniej miękkiej podkładki, która zabezpieczy przed zarysowaniem powierzchni. Niewielkie zauwaSalne ślady polerowania i szlifowania są związane z procesem produkcyjnym i nie są podstawą do reklamacji.</p> <p><b>Powierzchnie olejowane i woskowane:</b> Proszę unikać wilgoci na powierzchni i natychmiast likwidować ślady napojów. Proszę zwrócić uwagę Se powierzchnia jest zabezpieczona na 6 miesięcy, po których naleSy ją zabezpieczyć ponownie. Powierzchnie stółów mogą wymagać odnowienia znacie częściej niS przed upływem 6 miesięcy, odpowiednie środki chemiczne są dostępne sklepach specjalistycznych. Płyny i środki czystości mogą zmienić wygląd drewna</p> <p><b>Powierzchnie szklane:</b> Proszę nie kłaść Sądnych gorących lub zimnych przedmiotów na powierzchnie szklane Proszę nie uSywać powierzchni szklanych do cięcia na niej przedmiotów bez właściwego zabezpieczenia tej powierzchni</p> <p><b>Meble tapicerowane i poduszki:</b> Powierzchnia tapicerowana (materiał) moSe ulec odbarwieniu. Szczególnie istotne jest, Se farbowane ubrania mogą spowodować przebarwienia na powierzchni tapicerowanej (materiale). To dotyczy szczególnie jasnych materiałów i powierzchni tapicerowanych. Odbarwienia spowodowane zabrudzeniem przez odzieŚ nie jest podstawą do reklamacji.</p> <p><b>Powierzchnie metalowe:</b> Male widoczne ślady szlifowania szlifowania są związane procesem produkcji i nie są podstawą do reklamacji.</p>
---	--

<p><b>RU -</b> <b>RU - Общие сведения</b> Пожалуйста, следите за регулярным проветриванием помещений. Сухой воздух вызывает деформацию древесины. Влагу или воду сразу же вытирайте сухой тканью. Пожалуйста, не повредите поверхность острыми режущими или колющими предметами. Пожалуйста, не обрабатывайте поверхности едкими чистящими средствами. Для очистки поверхности используйте только влажную ткань. Этот товар предназначен исключительно для частного использования в быту! Цельная древесина Маленькие сучки, срастания и разрывы являются естественными образованиями и не могут служить поводом для рекламации. Различия в цвете и структуре прожилок свидетельствуют о подлинности древесины и не являются дефектами. Лакированная поверхность Пожалуйста, не ставьте предметы без соответствующей подставки. Возможные следы шлифовки и полировки обусловлены производственным процессом и не являются дефектами. Промасленная и вошенная поверхность Избегайте попадания воды на внешнюю поверхность и сразу же вытирайте остатки напитков. Пожалуйста, не забывайте о том, что при обычном использовании эта мебель остается защищенной примерно на 6 месяцев, а затем ее следует подвергнуть дополнительной обработке. Поверхности, подвергаемые особенно сильному воздействию, например, столешницы, должны проходить повторную обработку значительно раньше и чаще. Подходящие материал для ухода Вы найдете в специализированных магазинах. Пожалуйста, всегда помните, что содержащие красители жидкости или чистящие средства существенно влияют на вид древесины. Стеклопанельная поверхность Пожалуйста, не ставьте горячие или очень холодные предметы без соответствующей подставки на стеклянную поверхность. Пожалуйста, не используйте стеклянную поверхность в качестве рабочей поверхности для резки и иных подобных действий. Мягкая обивка и подушки Материал постельных принадлежностей может полинять при определенных обстоятельствах. Непрочно окрашенные ткани могут полинять на мебельную обивку. Это в особенности касается светлых обивочных материалов. Маркость окраски постельных принадлежностей не может служить поводом для рекламации материала обивки. Металлическая поверхность Едва видимые следы шлифовки под слоем покрытия обусловлены производственным процессом и не являются дефектами.</p>	<p><b>NL - Algemeen</b> Zorg voor regelmatige ventilatie van de ruimten. Te droge lucht bevordert het kromtrekken van het hout. Vocht onmiddellijk met een droge doek wegvagen. Alle oppervlakken niet met scherpe of puntige voorwerpen beschadigen. Oppervlakken niet met agressieve poets- of schoonmaakmiddelen behandelen. Om de oppervlakken te behandelen alleen een vochtige doek gebruiken. Dit product is uitsluitend voor privégebruik ontworpen!</p> <p><b>Massief hout</b> Fijne knoesten, vergroeiingen en kleine scheurtjes zijn een natuurlijk verschijnsel en geven reden voor klachten. Kleurverschillen en verschillend verloop van nerven getuigen van de echtheid van het hout en zijn geen kwalitatief gebrek.</p> <p><b>Gelakte oppervlakken</b> Voorwerpen niet zonder een geschikte onderzetter op de oppervlakken zetten. Eventueel zichtbare polijst- en schuursporen zijn veroorzaakt door de vervaardiging en vormen geen kwalitatief gebrek.</p> <p><b>Met olie of was behandelde oppervlakken</b> Voorkom dat er zich water op het oppervlak ophooft en verwijder drankresten onmiddellijk. Houd er rekening mee dat dit meubelstuk bij normaal gebruik slechts voor ca. 6 maanden beschermd is en daarna nabehandeld moet worden. Bijzonder zwaar belaste oppervlakken, zoals die van tafels, moeten beduidend vroeger en vaker nabehandeld worden, geschikt onderhoudsmateriaal is in de vakhandel verkrijgbaar. Houd er rekening mee dat gekleurde vloeistoffen of schoonmaakmiddelen het uiterlijk van het hout blijvend veranderen.</p> <p><b>Glazen oppervlakken</b> Geen hete of erg koude voorwerpen zonder geschikte onderzetter op het glazen oppervlak zetten. Het glazen oppervlak niet als werkblad voor snijden en dergelijke gebruiken.</p> <p><b>Kussens en vulling</b> Kledingtextiel kan in sommige gevallen afgeven. Niet-keurechte kleding kan afgeven op de bekledingstof. Dit geldt vooral voor lichte bekledingstoffen. Afgeven van kledingtextiel kan door ons niet als reden voor een klacht over de bekledingstoffen worden erkend.</p> <p><b>Metalen oppervlakken</b> Enigszins zichtbare sporen van het schuren onder de coating zijn veroorzaakt door de vervaardiging en geen kwalitatief gebrek.</p>
---	--

<p><b>TR - Genel bilgi</b>                  Ürünlerin bulunduğu odaları düzenli bir şekilde havalandırınız.                  Kuru hava tahtanın deformasyonuna, yumulmasına yol açar.                  Yüzeyleri nemli ve ıslak bir şekilde bırakmayınız- hemen kuru bir bezle siliniz.                  Keskin ve sivri aletlerle üst yüzeylere zarar vermemeyiniz.                  Zararlı ve keskin deterjan ile temizlemeyiniz.                  Üst yüzeyleri lütfen sadece nemli bir bez ile temizleyiniz, ve ardından bir kuru bez ile durulayınız.                  Bu ürün sadece ev kullanımı için üretilmiştir!  <b>Masif ahsap</b>                  Ince dal, doku deformasyonları ve ufak yarıklar doğanın verdiği özellikler ve bu yüzden şikayet sebebi değildir. Renk farklılığı ve farklı doku görüntüsü tahtanın sağlığını gösterir ve bir kalite hatası olarak kabul edilmeyiştir..  <b>Çilalanmış yüzeyler</b>                  Uygun bir altlık kullanmadan çilalanmış yüzeylere esya koymayınız.                  Görünen parlatma veya cila izleri üretim sürecisinden kalmaz ve kalite eksikliği değildir.  <b>Yağlanmış ve mumlanmış yüzeyler</b>                  Yağlanmış ve mumlanmış yüzeyler                  Yüzye de oluşabilen su birikimini önleyiniz ve hemen içecek artılarını temizleyiniz.                  Lütfen Dikkat, bu mobilya türü sadece 6 ay boyunca korunmalıdır ve kesinlikle ardından bakım altına alınması gerekir.                  Son dereceye kadar kullanılması masa üst yüzeyleri tabiki daha ereken ve daha sık korunma altına alınması gerekir.                  Dikkat ediniz, boyalı sıvı veya deterjanlar tahtanın karakterini kalici bir şekilde degistirebilir.  <b>Cam yüzeyleri</b>                  Lütfen asiri sıcak veya asiri soguk esya uygun bir altlık kullanmadan cam üstüne koymayınız.                  Cam yüzeyleri kesme altli olarak kullanmayınız.  <b>Koltuk ve yastik</b>                  Giyim kumaslari renk birakabilir. Renk sahihligi sahib olmayan giyim tekstilleri kaplama kumaslarda renk birakabilir.                  Açık renkli koltuk kaplama kumaslari için bu bilgi önemli olabilir.                  Bu yüzden giyim tekstillerden oluşan boyalakeleri ürün hatası olarak kabul edemeyiz.  <b>Metal yüzeyler</b>                  Hafifden kaplamanın altında gözükün parlatma veya cila izleri üretim sürecisinden kalmaz ve kalite hatası olarak kabul edilmiyor.</p>	<p><b>RO - Generalități</b>                  Asigurați-vă că încăperile sunt aerisite cu regularitate.                  Aerul prea uscat favorizează deformarea lemnului.                  Ștergeți imediat petelele umede și lichidele cu o cârpă uscată.                  Nu deteriorați suprafețele cu obiecte ascuțite sau tăioase.                  Nu tratați suprafețele cu detergenți sau alte substanțe de curățare agresive.                  Pentru curățarea suprafețelor folosiți doar o cârpă umezită cu apă.                  Acest produs este destinat exclusiv utilizării în mediul casnic.  <b>Lemn masiv</b>                  Nodurile fine, protuberanțele și crăpăturile de mici dimensiuni sunt caracteristici naturale și nu constituie motive de reclamație.                  Diferențele cromatice și textura fibrei atestă autenticitatea lemnului și nu sunt considerate defecte calitative.  <b>Suprafețe lacuite</b>                  Nu așezați pe aceste suprafețe obiecte fără un suport de protecție adecvat.                  Eventualele urme vizibile de șlefuire sau lustruire sunt cauzate de procesul de producție și nu sunt considerate defecte calitative.  <b>Suprafețele tratate cu ulei sau ceară</b>                  Evitați expunerea suprafeței la umezeală persistentă și îndepărtați imediat petele de lichide.                  Luați în considerare faptul că acest obiect de mobilier este protejat numai pentru o perioadă de 6 luni în condiții de utilizare normală, după care trebuie tratat suplimentar.                  Suprafețele extrem de solicitate, de exemplu tăbliile meselor, necesită aplicarea tratamentului suplimentar mult mai devreme și mai frecvent; substanțele de întreținere adecvate se găsesc în magazinele de specialitate.                  Țineți seama de faptul că lichidele sau substanțele de curățare colorate pot schimba permanent aspectul lemnului.  <b>Suprafețe din sticlă</b>                  Nu așezați pe suprafața din sticlă obiecte foarte fierbinți sau reci, fără un suport de protecție adecvat.                  Nu folosiți suprafața din sticlă ca suprafață de lucru pentru tăierea alimentelor sau pentru alte operațiuni similare.  <b>Piapumi și perne</b>                  În anumite circumstanțe, culoarea materialului textil din care sunt fabricate obiectele de îmbrăcăminte se poate transfera. Culoarea nerezistentă la transfer a hainelor se poate impregna pe materialul din care sunt fabricate articolele de pat. Această problemă apare mai ales la materialele deschise la culoare. Transferul culorilor de pe obiectele de îmbrăcăminte nu este considerat motiv de reclamație.  <b>Suprafețe din metal</b>                  Urmele de șlefuire ușor vizibile sub stratul aplicat pe suprafața metalică sunt cauzate de procesul de producție și nu reprezintă defecte calitative.</p>
--	--

<p><b>I - Informazioni generali</b>                  Provvedere a una aerazione regolare dei locali.                  Un'aria troppo secca favorisce la deformazione del legno.                  Rimuovere immediatamente umidita e liquidi con un panno asciutto.                  Non danneggiare le superfici con oggetti affilati o appuntiti.                  Non trattare le superfici con prodotti detergenti o di pulizia aggressivi.                  Per la pulizia delle superfici utilizzare unicamente un panno umido.                  Questo prodotto e destinato solo all'uso in ambienti domestici privati!  <b>Legno massiccio</b>                  Piccoli nodi, concrecenze e piccole fessure sono caratteristiche naturali del legno e non sono motivo di reclamo.                  Differenze di colore e direzioni diverse delle venature provano l'autenticità del legno e non rappresentano un difetto di qualità.  <b>Superfici verniciate</b>                  Non appoggiare oggetti direttamente sulle superfici ma provvedere ad un supporto adeguato.                  Eventuali tracce di lucidatura e levigatura visibili sono dovute alla produzione e non rappresentano un difetto di qualità.  <b>Superfici oleate e cerate</b>                  Evitare ristagni d'acqua sulla superficie e rimuovere immediatamente residui di bevande.                  Tenere presente che questo mobile, in condizioni d'uso normale, e protetto per soli 6 mesi e che successivamente deve essere trattato nuovamente.                  Superfici molto utilizzate come quelle di tavoli devono essere trattate molto prima e spesso; il prodotto adatto per la cura e reperibile presso i rivenditori specializzati.                  Tener presente che i liquidi colorati o detergenti cambiano in permanenza l'aspetto del legno.  <b>Superfici in vetro</b>                  Non appoggiare sulla superficie in vetro oggetti molto caldi o molto freddi senza un supporto adeguato.                  Non utilizzare la superficie in vetro come superficie di lavoro per tagliare qualcosa o svolgere altre attività simili.  <b>Imbottiture e cuscini</b>                  Il tessuto di capi di abbigliamento può perdere colore in determinate situazioni. Capi di abbigliamento di colore non naturale possono lasciare il colore sulla stoffa del rivestimento. Ciò vale in particolare per stoffe di rivestimento chiare.                  Una perdita di colore del tessuto di capi di abbigliamento non può essere da noi accettata come motivo di reclamo per le stoffe di rivestimento.  <b>Superfici in metallo</b>                  Tracce leggere di levigatura visibili sotto il rivestimento di finitura sono dovute alla produzione e non sono un difetto di qualità.</p>	<p><b>SK - Všeobecné</b>                  Dbajte na pravidelné vetranie miestnosti.                  Prliš suchý vzduch spôsobuje rozťahovanie dreva.                  Vlhkosť a mokrú utrite ihneď suchou handričkou.                  Nepoškodte žiaden povrch ostrými alebo špicatými predmetmi.                  Povrchy neošetríte silnými leštiacimi alebo čistiacimi prostriedkami.                  Na čistenie povrchov používajte len navlhčenú handričku.                  Tento výrobok bol skoncipovaný len na použitie v domácnostiach!  <b>Masívne drevo</b>                  Jemné hrčky, zrsty a malé pukliny sú podmienené prírodou a nie sú dôvodom na reklamáciu.                  Farebné rozdiely a odlišné textúry svedčia o pravosti dreva a nepokladajú sa za žiadnu kvalitatívnu chybu.  <b>Lakované povrchy</b>                  Predmety nekladte na povrchy bez vhodnej podložky.                  Prípadné viditeľné leštené a brúsené stopy sú podmienené výrobou a nepredstavujú žiadnu kvalitatívnu chybu.  <b>Naolejované a navoskované povrchy</b>                  Vyňbajte sa trvalému zamokreniu na povrchu a ihneď odstráňte zvyšky rozliateho nápoja.                  Berte na vedomie, že tento nábytok je chránený pri bežnom používaní len cca. 6 mesiacov a potom si vyžaduje ďalšie oštenie.                  Obzvlášť náročné povrchy, ako povrchy stolov si vyžadujú následné oštenie podstatne skôr a častejšie, vhodný ošetrovací materiál dostanete v špecializovaných obchodoch.                  Berte na vedomie, že zafarbené tekutiny alebo čistiaci prostriedok natrvalo zmenia výraz dreva.  <b>Sklenené povrchy</b>                  Na sklenené povrchy nekladte žiadne horúce alebo veľmi studené predmety bez vhodnej podložky.                  Nepoužívajte sklenené povrchy ako pracovné plochy na krájanie alebo niečo podobné.  <b>Podhlavník a vankúš</b>                  Odevné textilie môžu za určitých okolností púšťať farbu. Nestálofarebný odev môže púšťať farbu na potahovú látku.                  Platí to hlavne pri svetlých potahových látkach. Púšťanie odevných textílií nemôžeme uznať ako dôvod na reklamáciu potahovej látky.  <b>Kovové povrchy</b>                  Ľahko viditeľné stopy po brúsení pri obhládke sú podmienené výrobou a nepovažujú sa za žiadnu kvalitatívnu chybu.</p>
--	---

<p><b>HR - Općenito</b>                  Molimo Vas pobrinute se da su vaše sobe ventilirane.                  Vrlo suh ili vrlo vlažan zrak će pridonijeti savijanju drvenih proizvoda.                  Obrisite tekućinu i vlažne mrlje odmah, mekom i suhom krpom.                  Sprječite oštre predmete od izravnog kontakta s površinom.                  Nemojte koristiti za pranje prah ili bilo koje druge tvari koje sadrže abrazive za čišćenje površine.                  Ovaj proizvod je namijenjen isključivo za uporabu u privatnim kućama !  <b>Puno drvo</b>                  Male kvržiće i male pukotine u drvu prirodna karakteristika drva , a ne razlog za reklamaciju .                  Razlike u boji i strukturi također su tipični za masivno drvo, a ne mana .  <b>Lakirane površine</b>                  Molim vas, nemojte staviti bilo kakav predmet bez prostirke na površinu , to bi moglo izazvati teške ogrebotine.  <b>Uljene i voskane površine</b>                  Proizvode za njegu treba primijeniti najkasnije ca . 6 mjeseci po prvi put .molimo primijetiti !                  Naulijene površinekao što su ploče stolova , treba tretirati ranije . Ne zaboravite ponoviti ovaj tretman u redovitim razmacima , pogodne materijale za njegu ćete dobiti na lokalnim specijaliziranim trgovinama.                  Obojene tekućine ili sapuni mogu oštetiti drvo.  <b>Staklene površine</b>                  Ne stavljajte jako vruće ili jako hladne predmete na staklenu površinu, koristite odgovarajuće podmetače kako takve stvari nebi došle u dodir sa staklom.                  Nemojte koristiti staklo kao površinu za cijepanje. Nemojte udarati časom s tvrdim ili šiljitim predmetima, koristite vlačnu krpu i sapunicu da očistite površinu.  <b>Metalne površine</b>                  Lako vidljive oznake od brušenja i poliranja površine su uvjeti proizvodnje , a ne razlog za reklamaciju .</p>	<p><b>SI - Splošno</b>                  Prosimo, da poskrbite, da so vaši prostori prezračeni.                  Zelo suh ali zelo vlažen zrak povzroča krivljenje lesnih izdelkov.                  Razlite tekočine ali vlago takoj obrišite s suho mehko krpo.                  Ne uporabljajte ostrih predmetov v stiku s površino.                  Za čiščenje površine ne uporabljajte detergentov ali drugih snovi, ki vsebujejo abrazivna sredstva.                  Ta izdelek je namenjen izključno za domačo uporabo.  <b>Masiven les</b>                  Majhne grče, izbokline in razpoke v lesu so naravne lastnosti lesa in niso razlog za reklamacijo.                  Razlike v barvi in strukturi so značilne za masiven les in se ne obravnavajo kot napake v kakovosti.  <b>Lakirane površine</b>                  Na površino ne odlagajte predmetov brez podloge.                  Morebiti vidni znaki brušenja in poliranja so posledica obdelave in niso razlog za reklamacijo.  <b>Oljene in voskane površine</b>                  Razlite tekočine takoj obrišite s suho krpo.                  Pohišstvo je pri normalni uporabi zaščiteno približno 6 mesecev. Izdelke za nego je potrebno ponovno nanesti po šestih mesecih                  Oljene površine, kot so na primer mizne plošče, je potrebno vzdrževati pogosteje. V rednih časovni presledkih ponavljajte postopek vzdrževanja. Ustrezne izdelke za nego dobite v specializiranih trgovinah.                  Obarvane tekočine in mila lahko poškodujejo les.  <b>Steklene površine</b>                  Na steklene površine ne odlagajte vročih ali mrzlih predmetov. Uporabite podstavke.                  Ne uporabljajte steklenih površin za rezanje. Po steklenih površinah ne udarjajte s trdimi in ostrimi predmeti. Za čiščenje površin uporabite vlažno krpo in milo.  <b>Vzglavniki in blazine</b>                  Tkanine lahko v določenih okoliščinah puščajo barvo. Barvno neobstoje ne lahko obaravajo druge tkanine, predvsem svetlejše tkanine. Takšen primer obarvanja ni razlog za reklamacijo.  <b>Kovinske površine</b>                  Znaki brušenja in poliranja na površini so posledica obdelave in niso razlog za reklamacijo</p>
---	--