

Allgemeine Hinweise

Die Montage einer Einbauküche sollte von entsprechend geschulten Fachkräften durchgeführt werden. Vor der Montage müssen die Montagehinweise gelesen werden.

Spezielle, weiterführende Montageanleitungen und Hinweise liegen den Geräten, Spülen, Beleuchtungen und Sonderausstattungen bei und müssen zusätzlich beachtet werden.

Für die Befestigung von Wandhängeelemente gilt:



Wir legen kein Befestigungsmaterial bei. Bitte prüfen Sie die gegebene Wandbeschaffenheit und wenden Sie sich an den örtlichen Fachhandel zum Erwerb der passenden Dübel / Haken / Aufhängeschienen / Schrauben

Für die Aufhängung können entweder Haken oder Aufhängeschienen verwendet werden.



Die Hängeschränke können bei korrekter Montage mit ca. 40 kg belastet werden. Achten Sie auf eine gleichmäßige Lastverteilung

Bei Nichtbeachtung der Montagehinweise können wir entstandene Schäden keine Haftung übernehmen

Achten Sie darauf bei Einzelschränken, oder der gesamten Küchenzeile eine Kippsicherung anzubringen

Sanitär- und Elektroinstallationen dürfen nur von einer entsprechenden Fachkraft vorgenommen werden

Vor Bohrarbeiten muss geprüft werden, dass an der Stelle des Bohrens keine Leitungen für Gas, Wasser, Strom, Heizung oder

Abflüsse verlegt wurden

Es dürfen keine verändernden Manipulationen am Zubehör oder an Elektrogeräten vorgenommen werden. Dies gilt insbesondere für Befestigungsbohrungen.

Überprüfen Sie vor der Montage ob alle Anschlüsse vorhanden sind und fachgerecht ausgeführt wurden

Die Küche beinhaltet verschluckbare Kleinteile. Kinder unter 3 Jahre nicht ohne Beaufsichtigung lassen



Empfohlenes Vorgehen bei der Küchenmontage:

Planen Sie den genauen Montageort unter Berücksichtigung Ihrer Sanitär- und Elektroanschlüsse

Prüfen Sie ob Ihr Kühl- Gefriergerät Lüftungsauslässe im Sockelbereich bzw. im Bereich der Arbeitsplatte benötigt

Erwerben Sie ggf. passende Lüftungsgitter im Fachhandel und schneiden Sie den Sockel bzw. die Arbeitsplatten gemäß den

Anweisungen des Geräteherstellers aus.

Legen Sie fest, ob Sie die Türen mit Rechts- oder Linksanschlag montieren wollen

Montieren Sie zunächst die Unterschränke und richten Sie diese mit einer Wasserwaage aus.

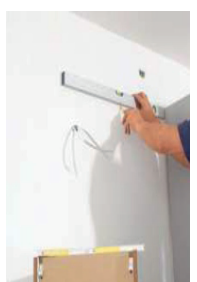

Erst wenn alles exakt steht, verbinden Sie die einzelnen Schränke mit Schrauben. Damit dabei nichts verrutscht, empfehlen wir Ihnen dringend den Einsatz von zwei Schraubzwingen. Die Schrankoberflächen schützen Sie mit Zulagehölzern vor Eindrücken.

Ermitteln Sie durch exaktes Messen die Positionen der Bohrungen für die Hängebeschläge

Legen Sie die Arbeitsplatte auf die Korpusse, richten Sie sie aus, und fixieren Sie sie mit Zwingen. markieren Sie die Lage und -breite des Herdunterschrankes.

Auf der Unterseite der Arbeitsplatte reißen Sie im markierten Bereich den Herdplattenausschnitt auf. Mitteln Sie sie aus, so dass die Spüle mittig im Unterschrank sitzt und vorne und hinten die Plattenrestbreite gleich wird.



Empfohlenes Vorgehen bei der Küchenmontage:

Bohren Sie in den vier Ecken jeweils ein 10-mm-Loch zum leichteren Einsetzen der Stichsäge, und schneiden Sie den Herdausschnitt entlang Ihrer Risse aus. Arbeiten Sie immer von der Plattenunterseite, damit die Plattenoberfläche durch die Stichsäge nicht ausfasert. Schalten Sie dazu auch den Pendelhub an Ihrer Stichsäge, sofern vorhanden, aus.

Zum Schutz der Holzteile können Sie rundum die Sockelteile eine Silikonnaht ziehen



Empfohlenes Vorgehen bei der Küchenmontage:

Bohren Sie in den vier Ecken jeweils ein 10-mm-Loch zum leichteren Einsetzen der Stichsäge, und schneiden Sie den Herdausschnitt entlang Ihrer Risse aus. Arbeiten Sie immer von der Plattenunterseite, damit die Plattenoberfläche durch die Stichsäge nicht ausfasert. Schalten Sie dazu auch den Pendelhub an Ihrer Stichsäge, sofern vorhanden, aus.

Zum Schutz der Holzteile können Sie rundum die Sockelteile eine Silikonnaht ziehen



Colli 5/6

- | | |
|------------------------|-------------------------|
| B1
φ 8x28 x6 | L22
x3 |
| T1
x4 | S9
4x16 x6 |
| M1
x4 | U42
420 x1 |
| F15
x4 | P14
3,5x30 x3 |
| X5
x2 | K5
7x50 x4 |
| S8
4x13 x4 | C5
x4 |
| D2
x2 | G7
x1 |

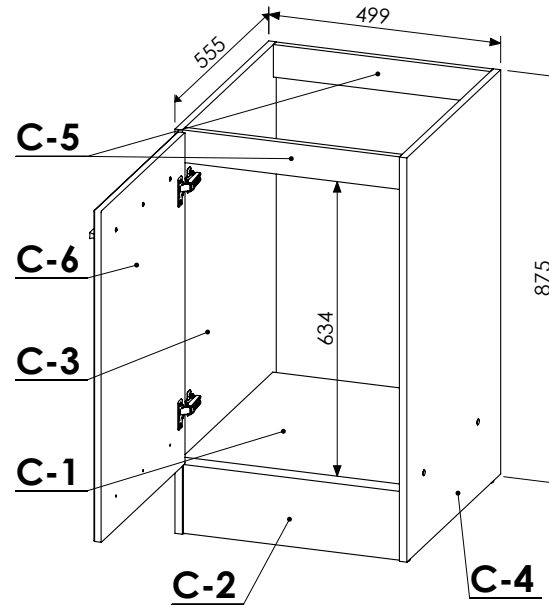



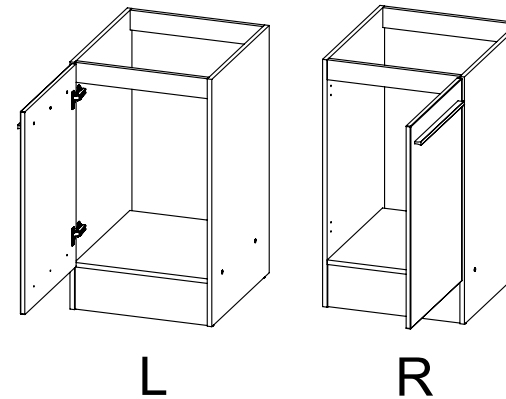

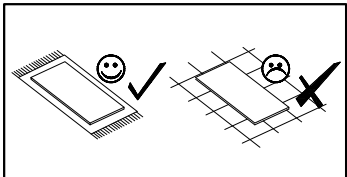
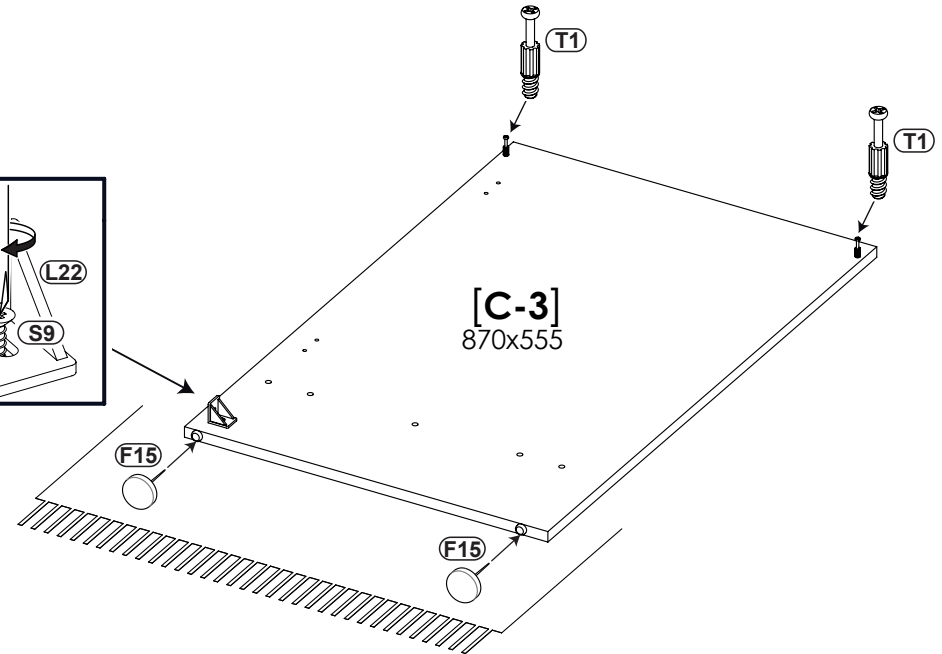
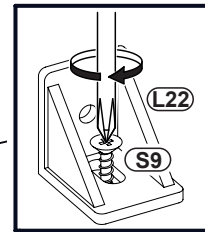
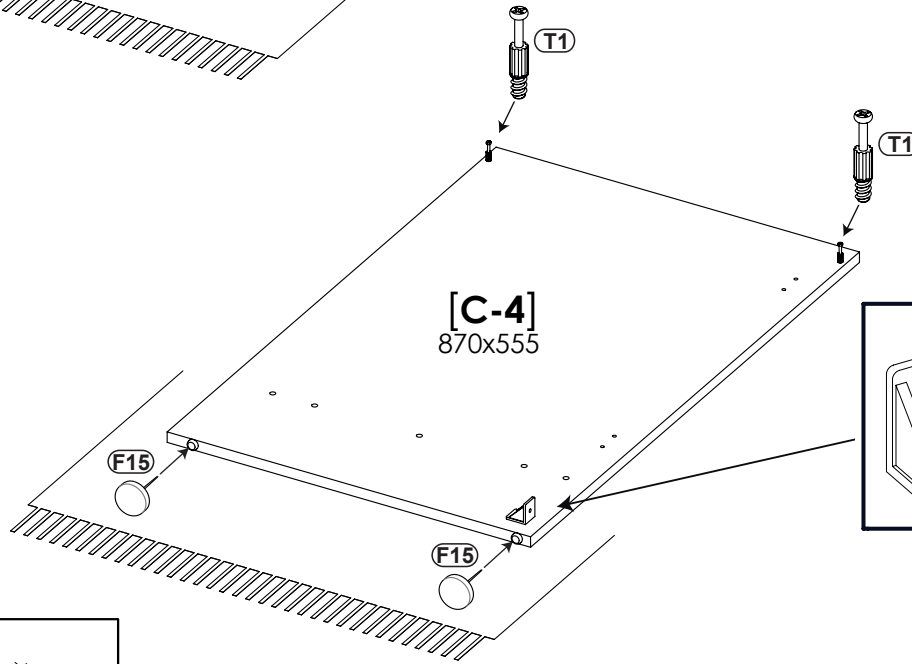
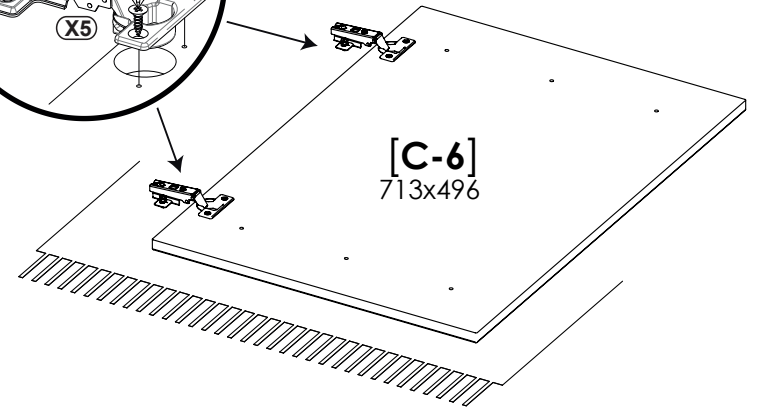
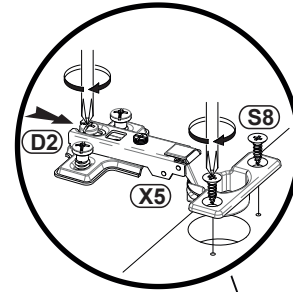
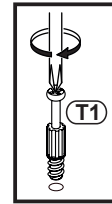
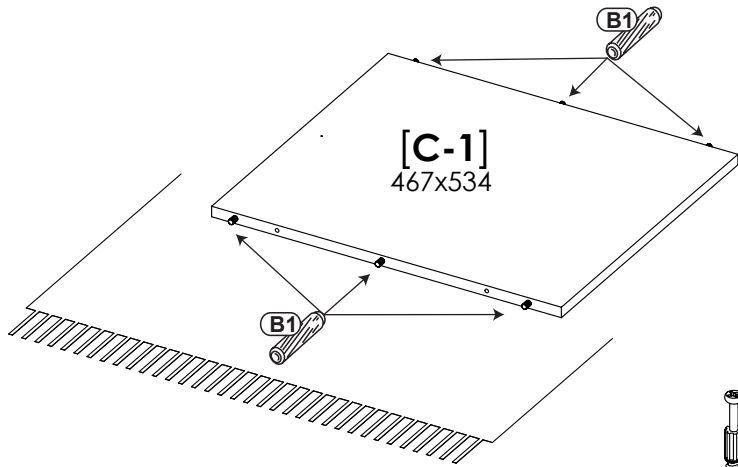
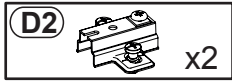
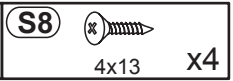
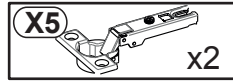
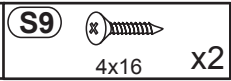
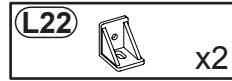
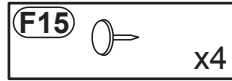
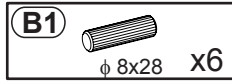
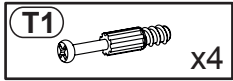

Nr	↘	↗	↖	pcs	
C-1	467	534	16	1	1
C-2	467	150	16	1	1
C-3	870	555	16	1	1
C-4	870	555	16	1	1
C-5	467	70	16	2	1
C-6	713	496	16	1	1



1



- 2** **M1**  x4
- K5**  7x50 x4
- C5**  x4
- G7**  x1

- 3** **L22**  x1
- S9**  4x16 x4

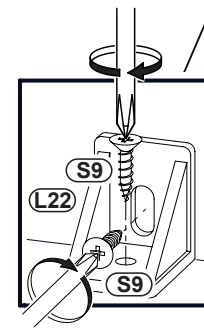
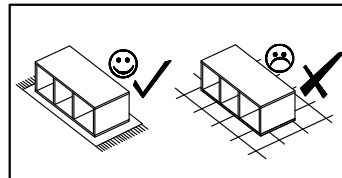
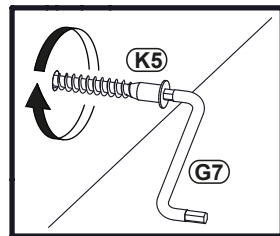
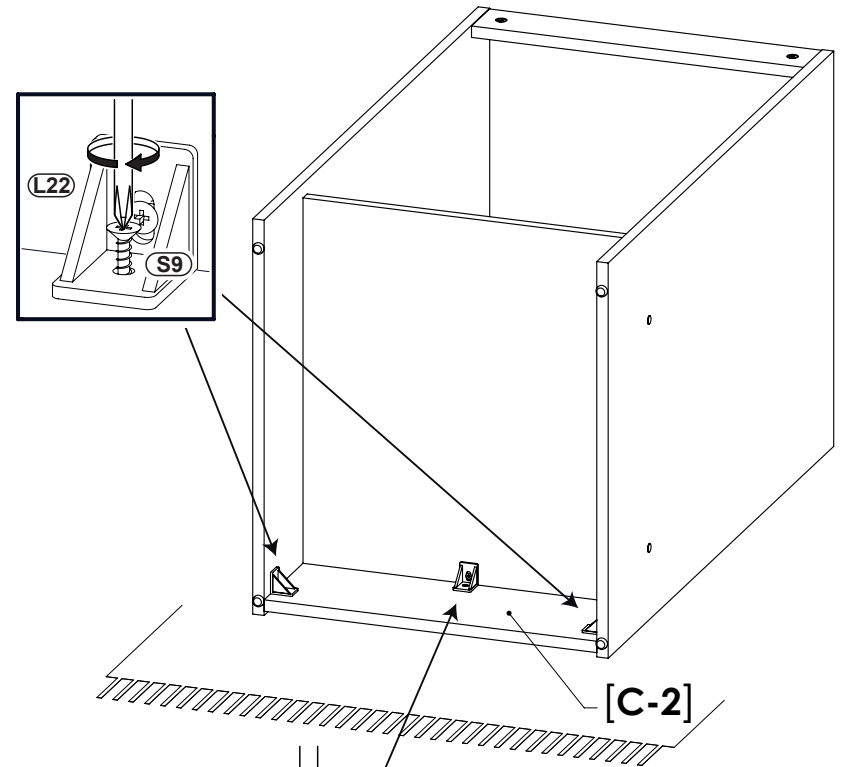
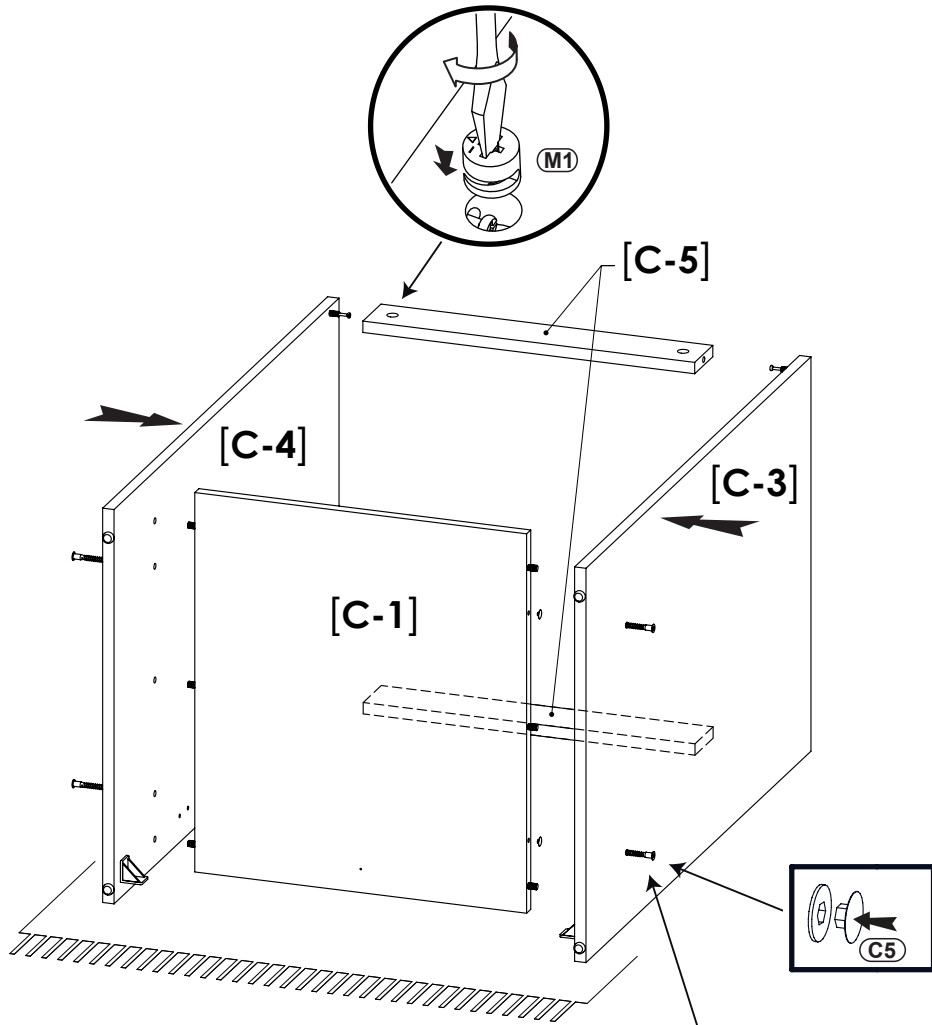

4

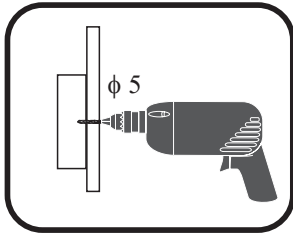
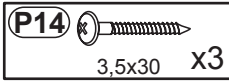
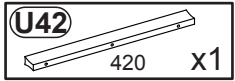



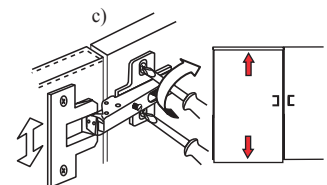
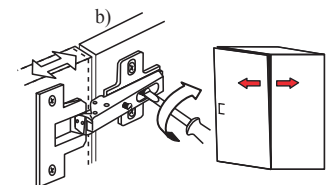
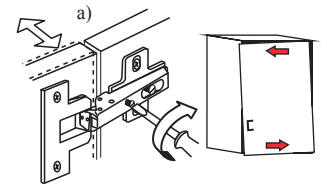
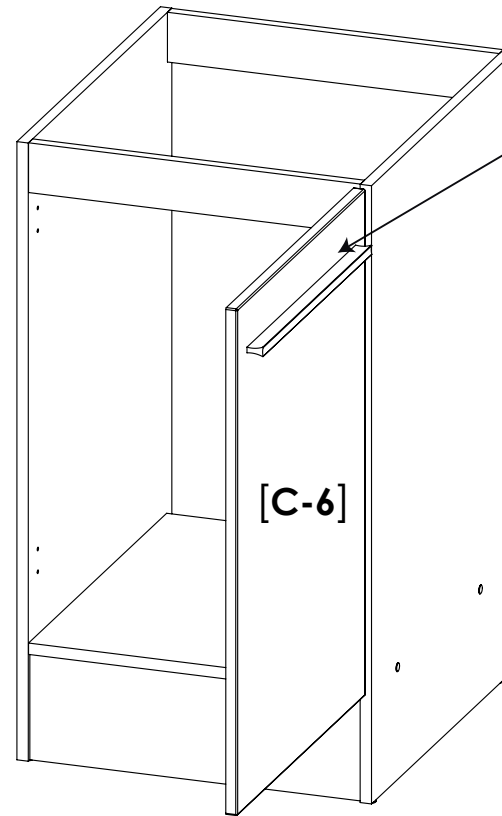
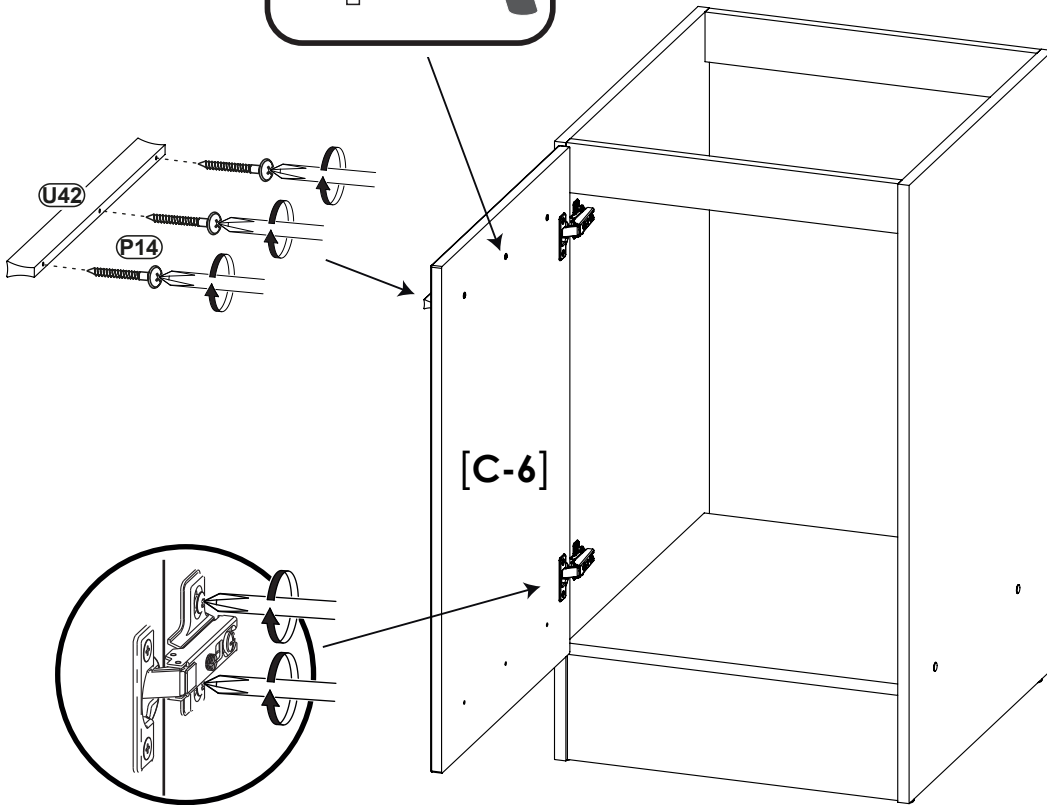

L

R

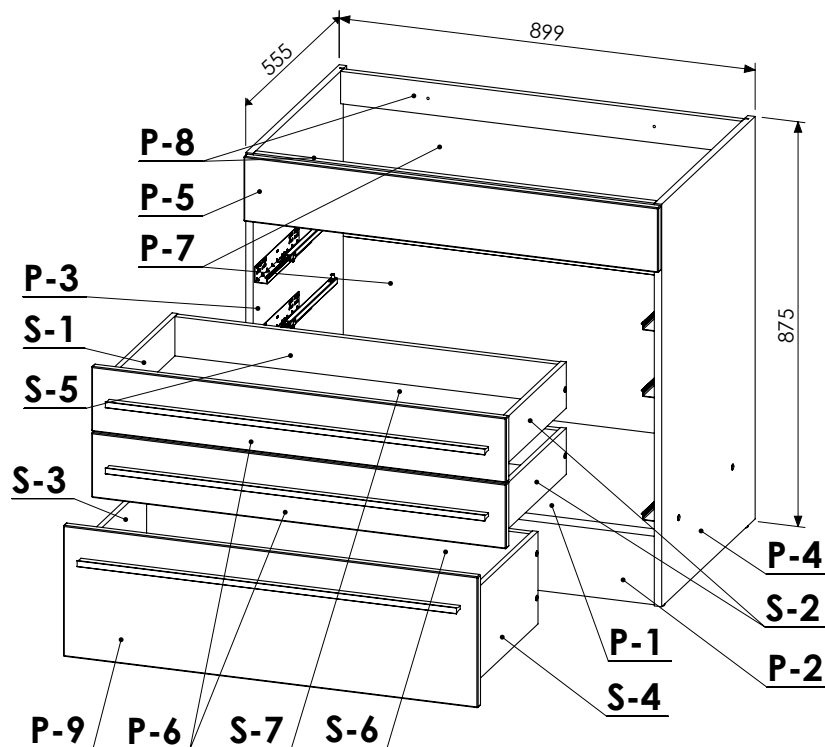
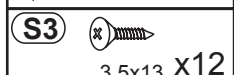
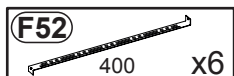
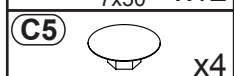
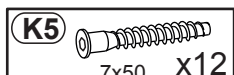
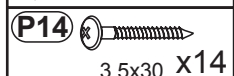
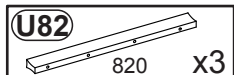
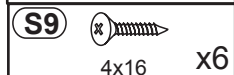
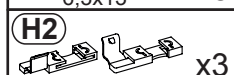
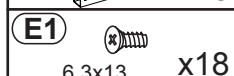
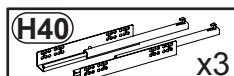
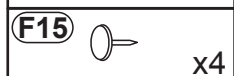
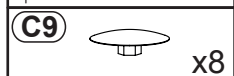
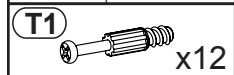
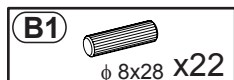

Colli 5/6



Nr				pcs	
P-1	867	534	16	1	2
P-2	867	150	16	1	2
P-3	870	555	16	1	2
P-4	870	555	16	1	2
P-5	896	140	16	1	2
P-6	896	140	16	2	2
P-7	358	881	2	2	2
P-8	867	70	16	2	2
P-9	896	283	16	1	2
S-1	402	100	12	2	2
S-2	402	100	12	2	2
S-3	402	200	12	1	2
S-4	402	200	12	1	2
S-5	828	85	16	2	2
S-6	828	185	16	1	2
S-7	838	407	2	3	2



1

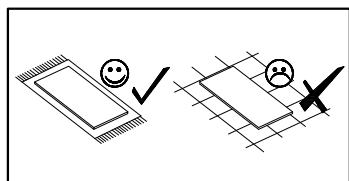
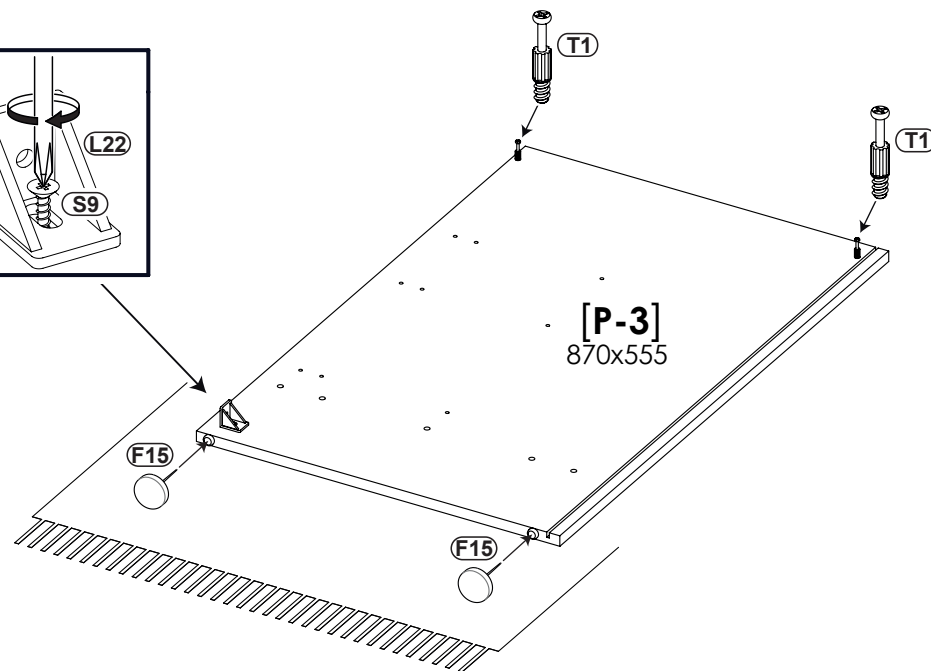
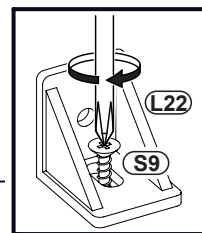
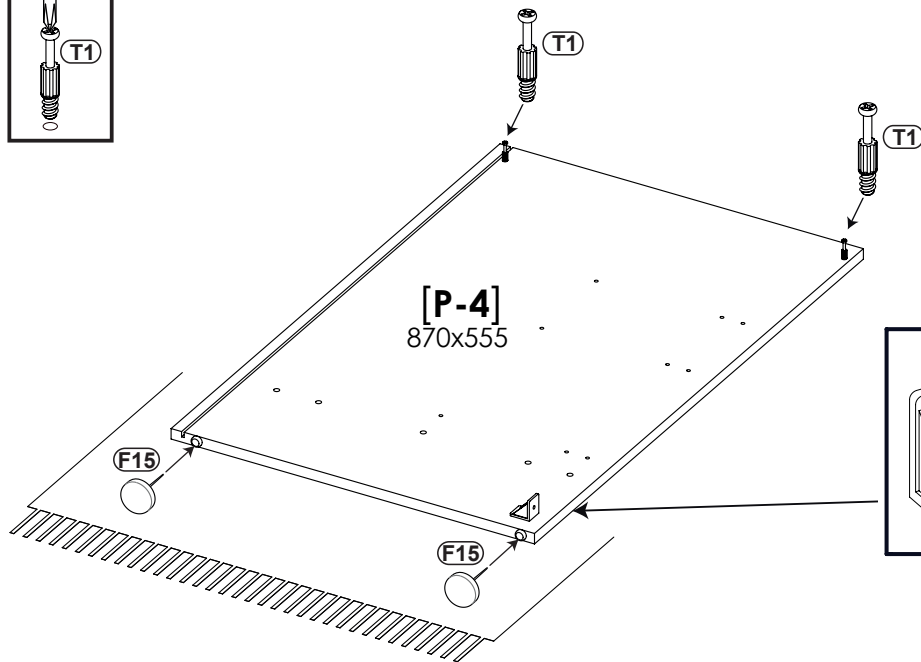
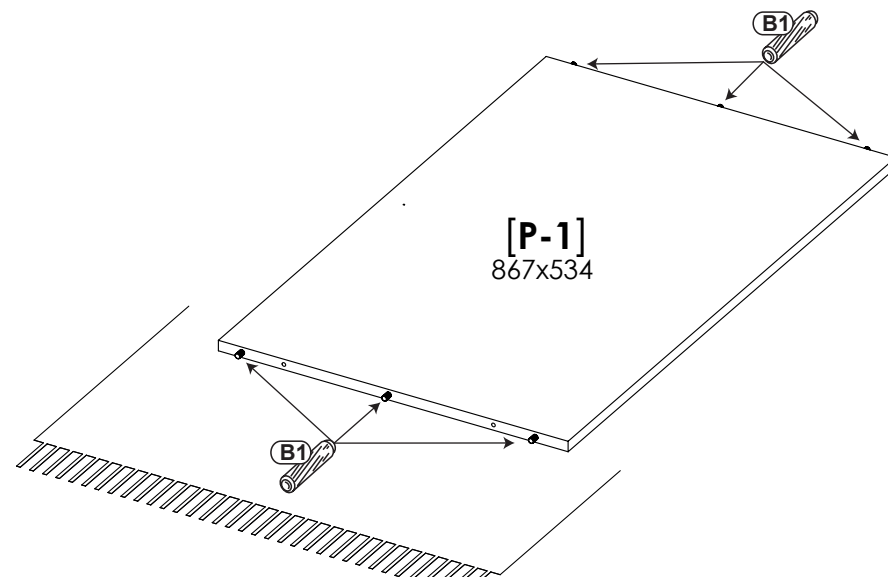
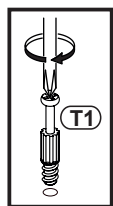
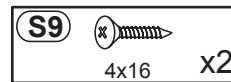
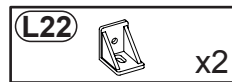
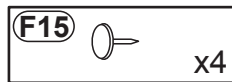
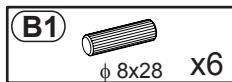
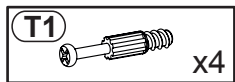

2

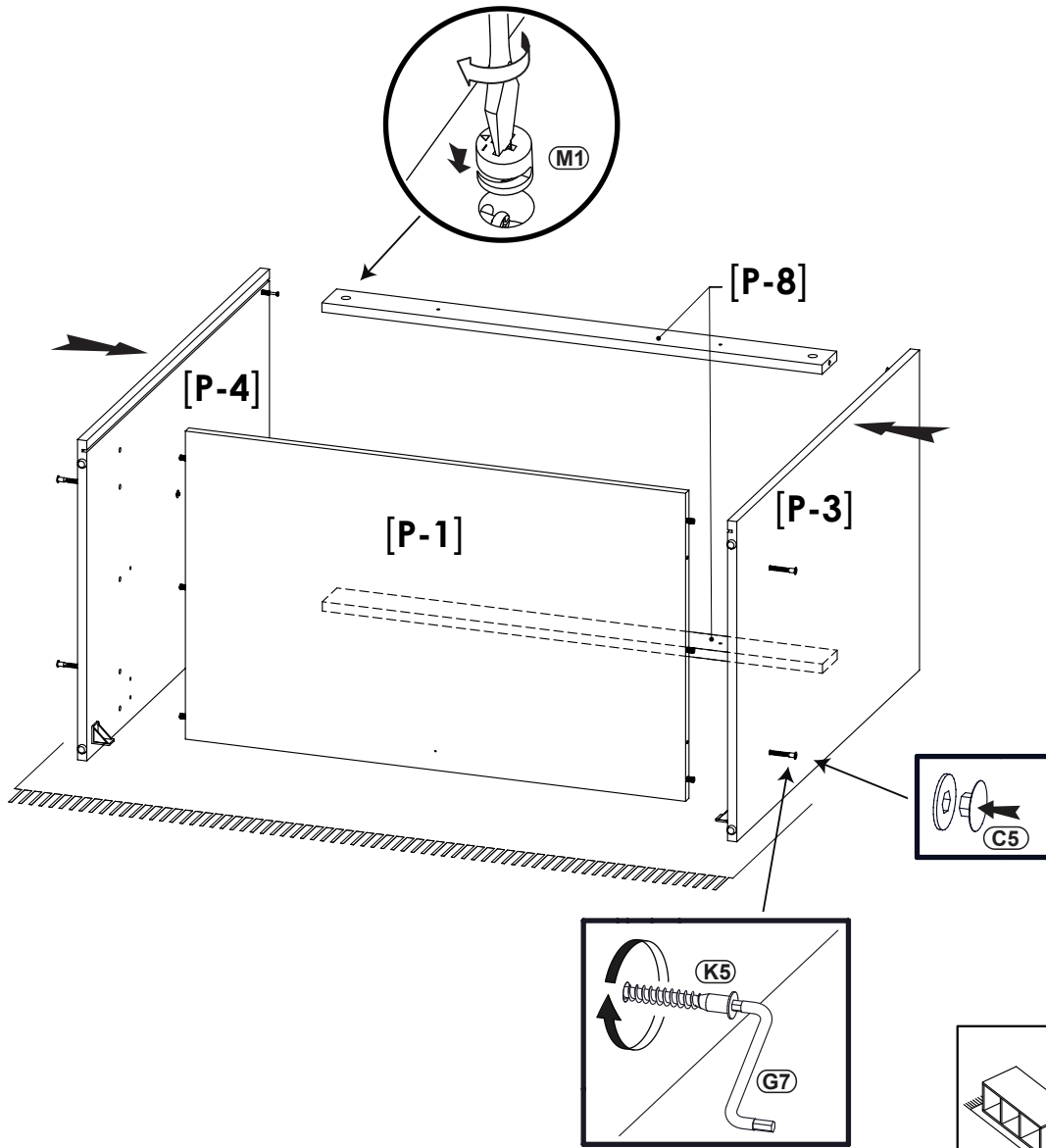
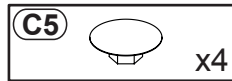
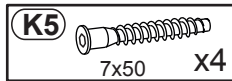

3

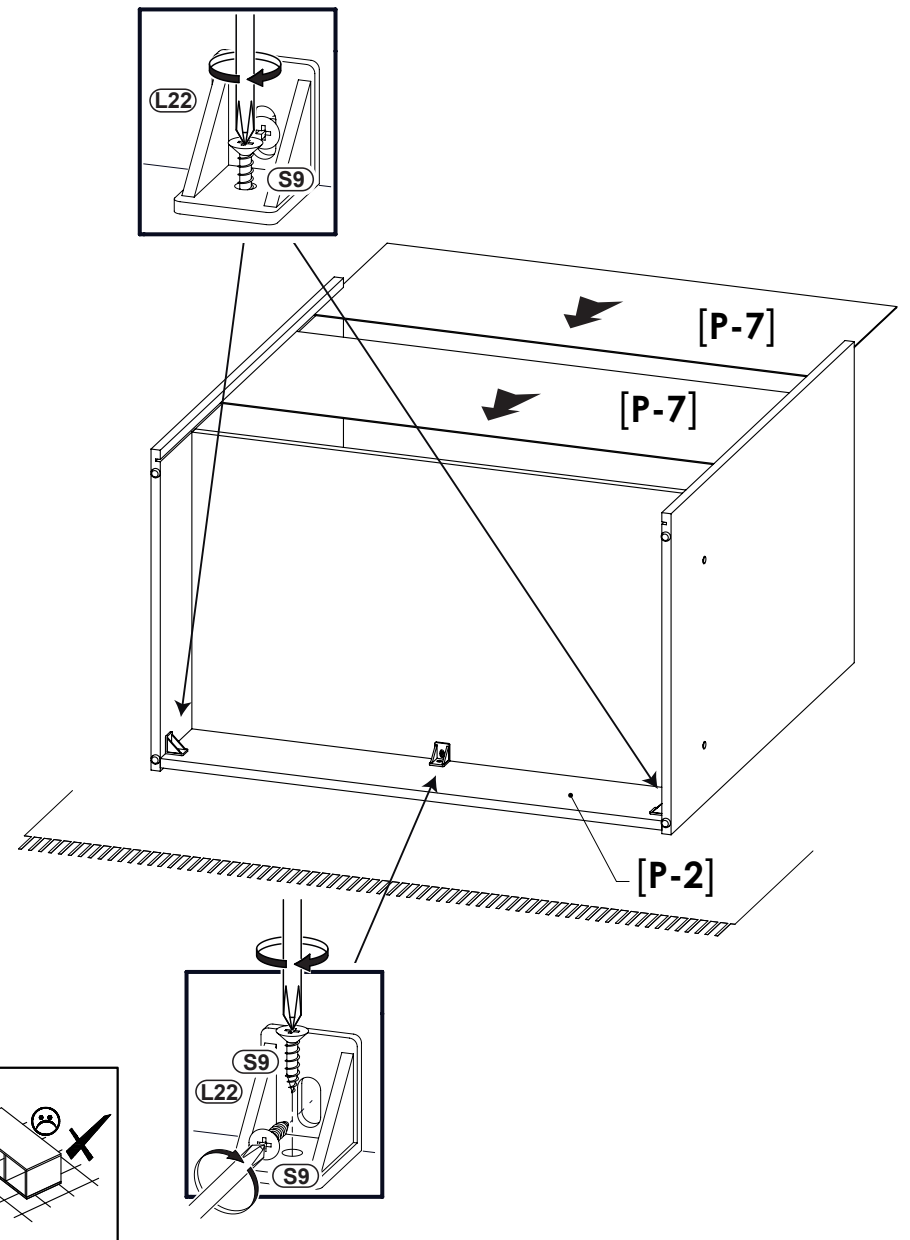
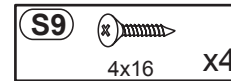

4

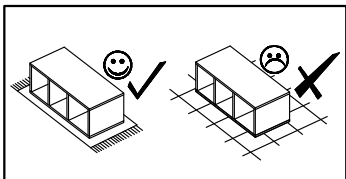
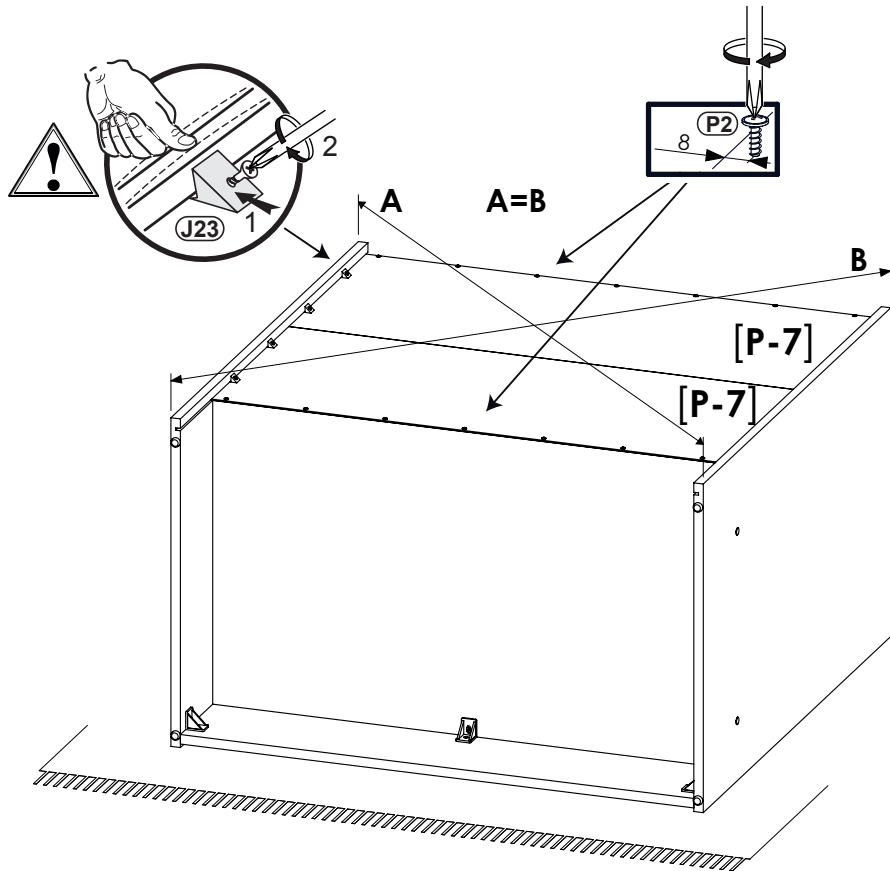
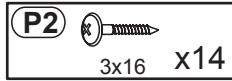
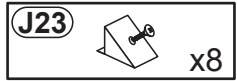

5

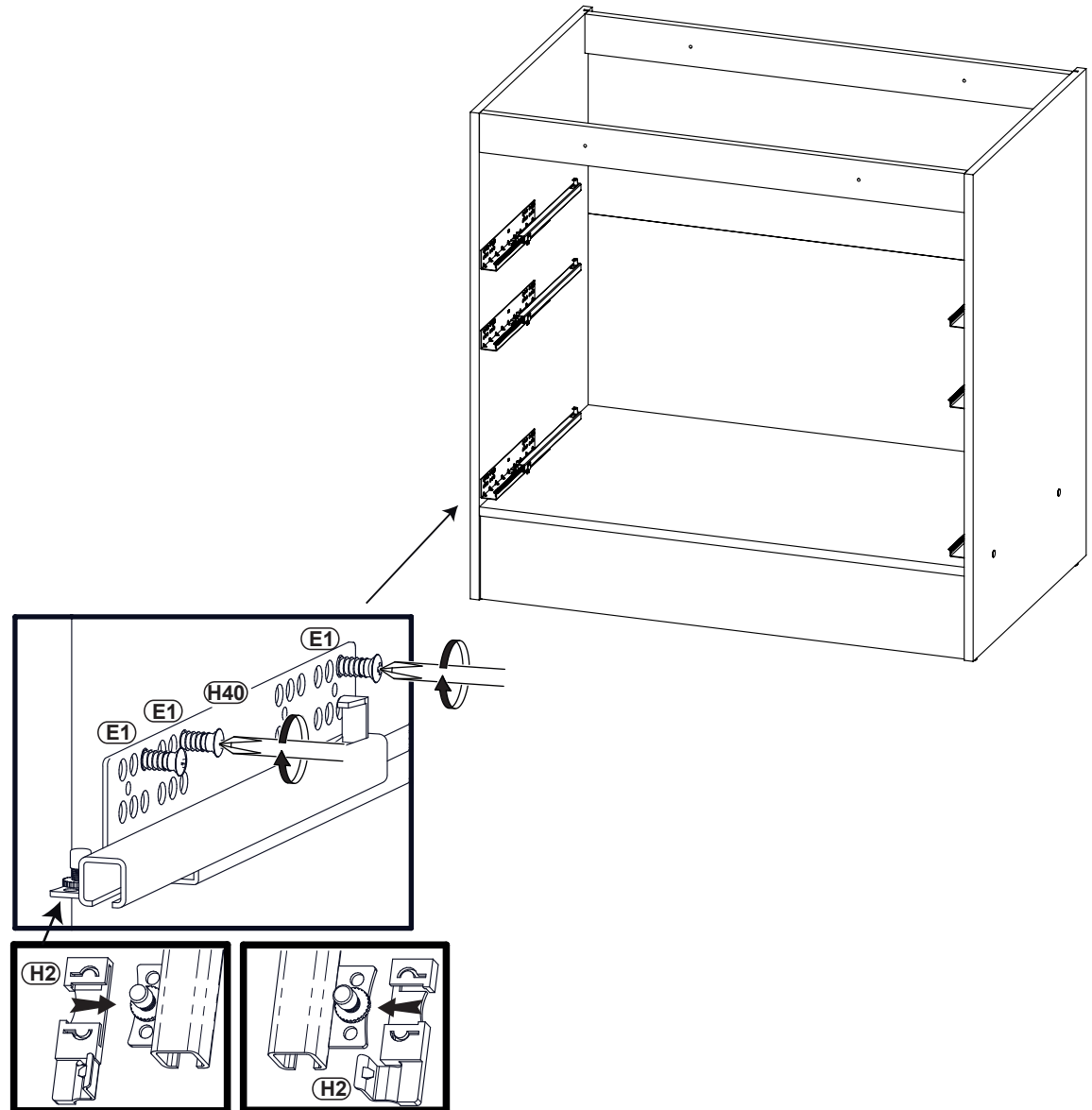
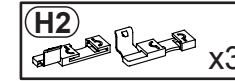
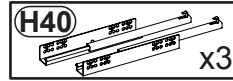

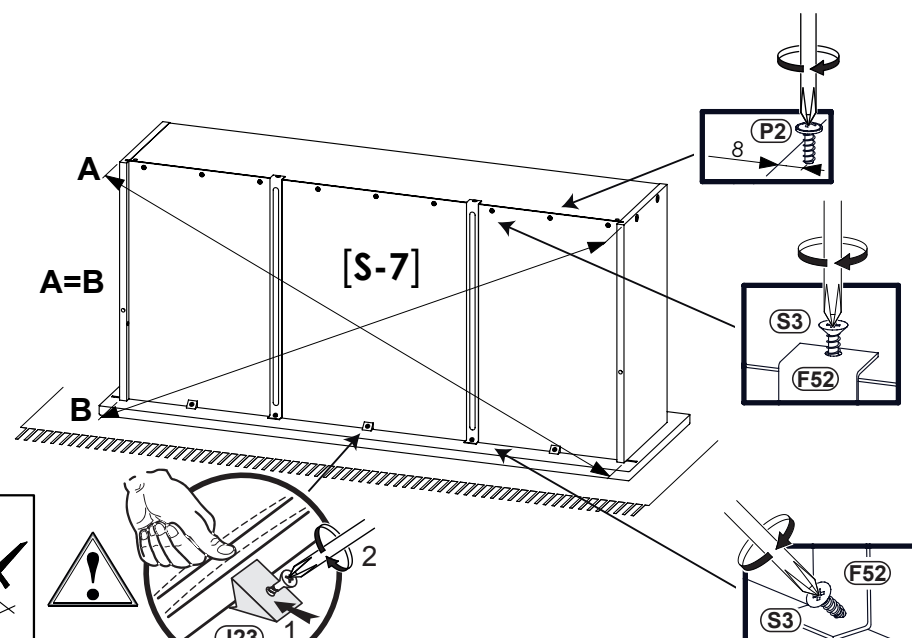
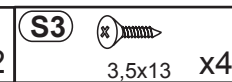
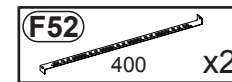
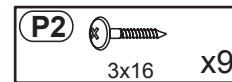
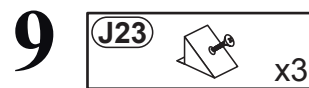
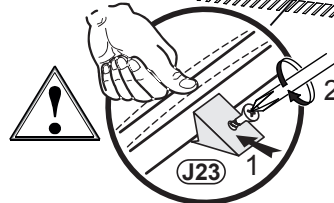
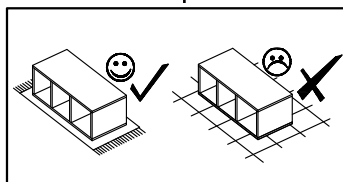
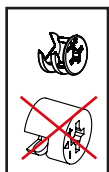
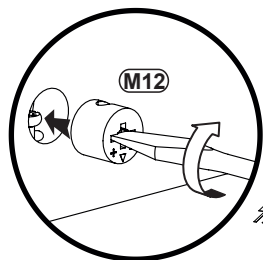
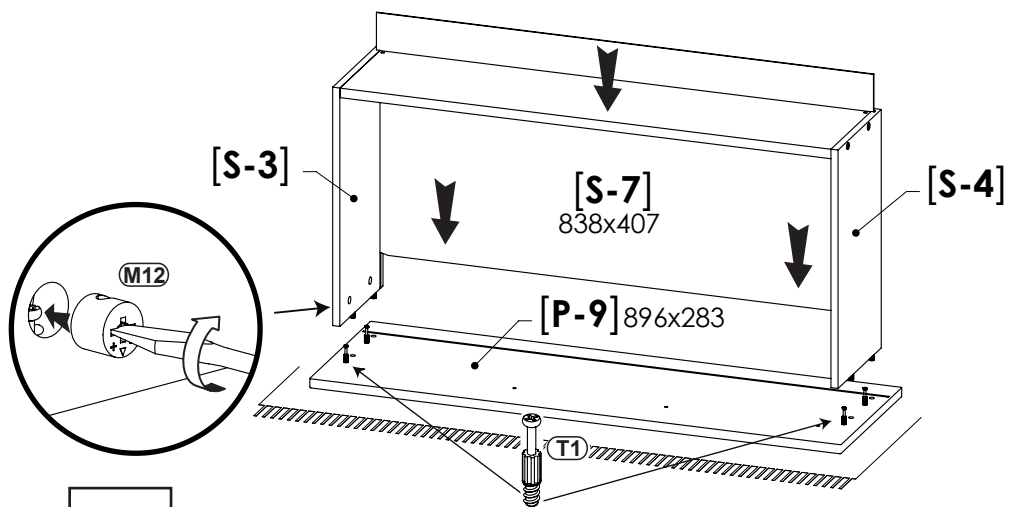
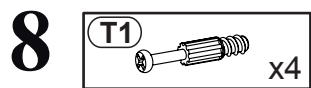
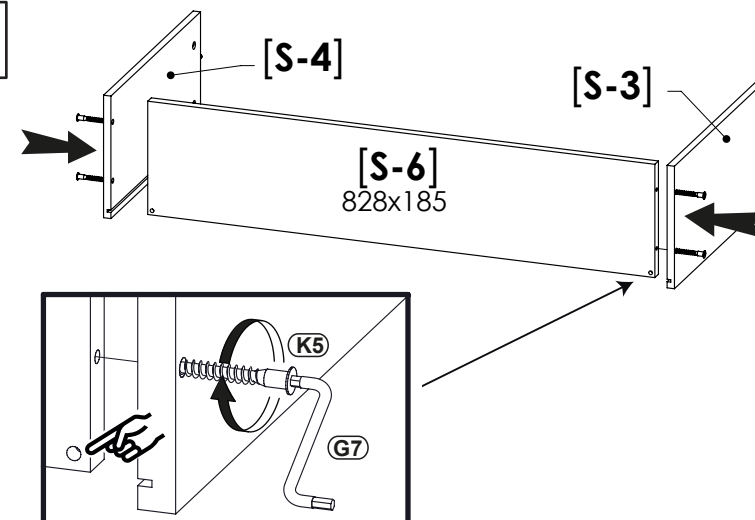
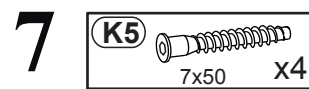
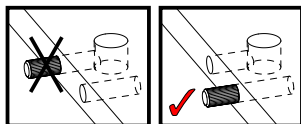
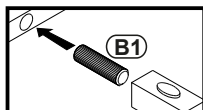
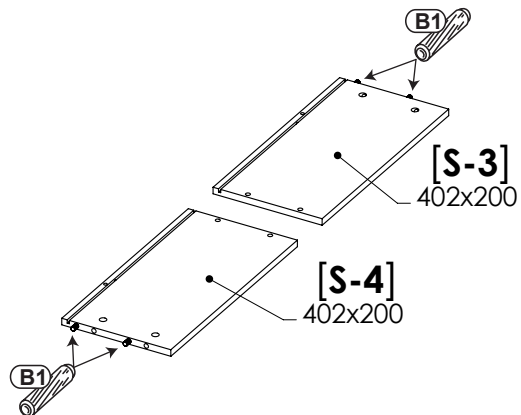
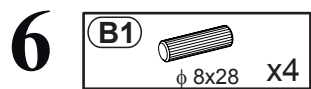

10

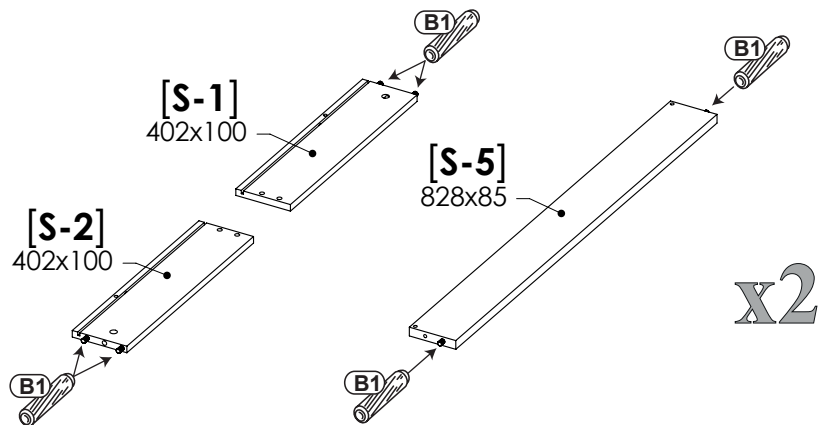
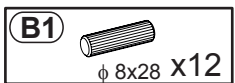

11

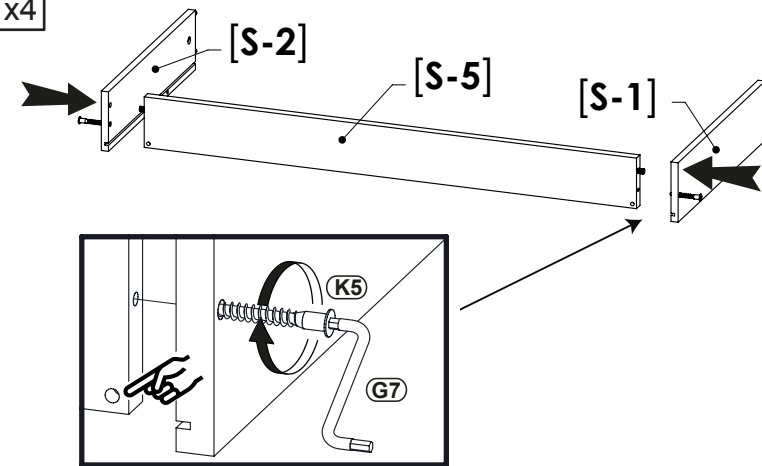
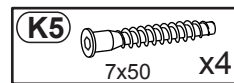

12

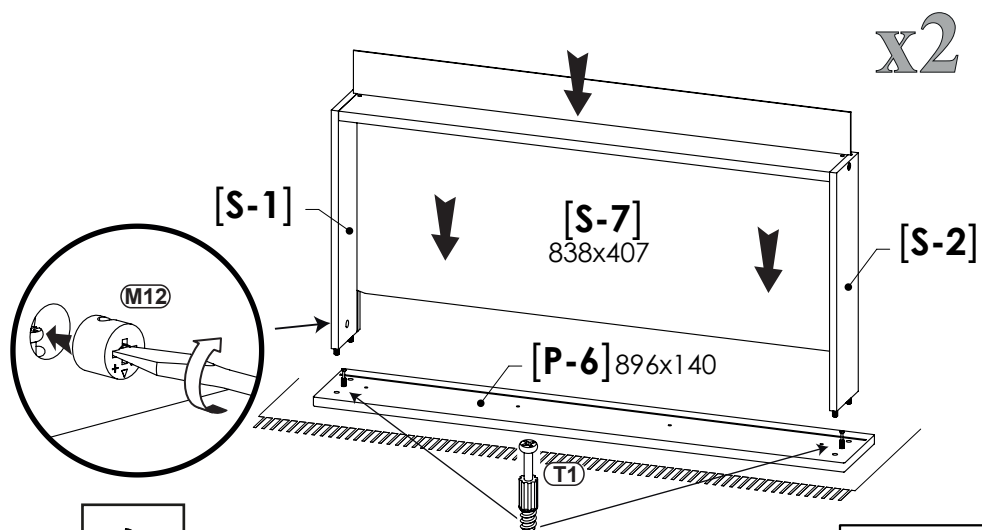
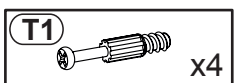

13

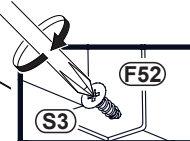
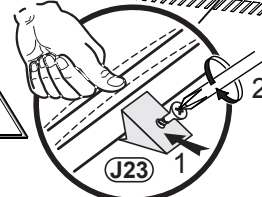
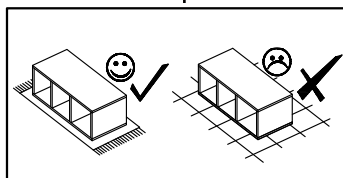
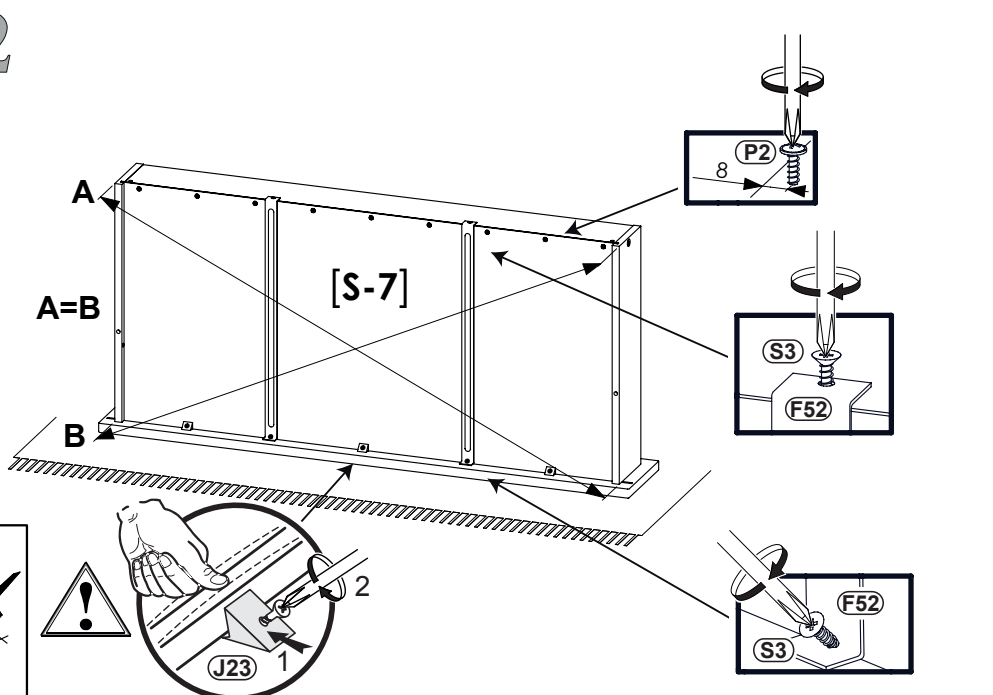
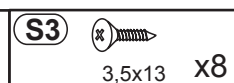
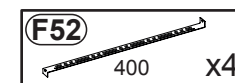
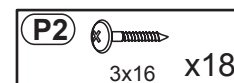
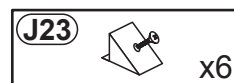

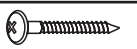
14 **P14**  3,5x30 x2

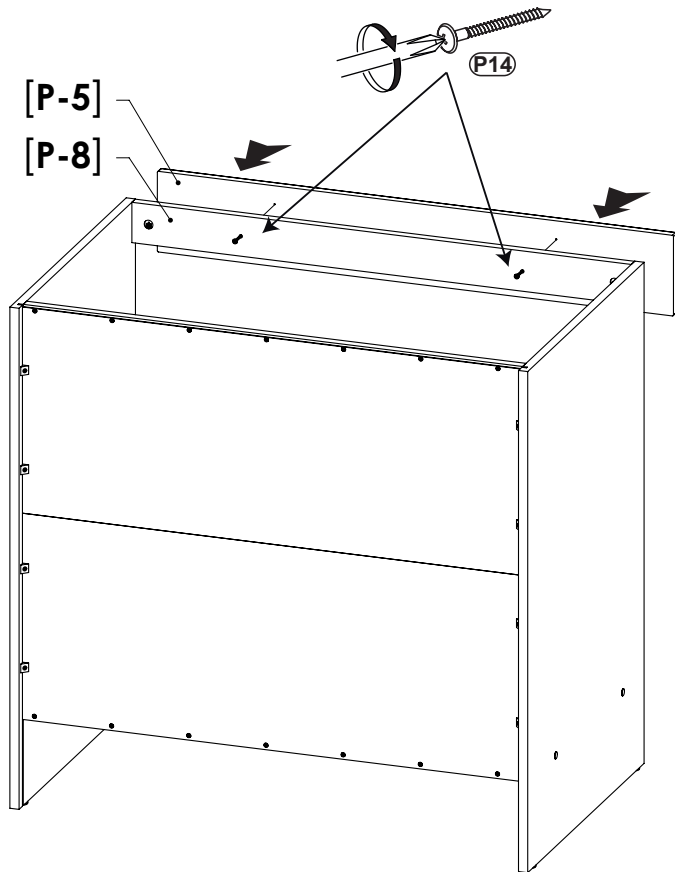

15 **U82**  x3

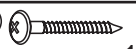
P14  3,5x30 x12

C9  x8

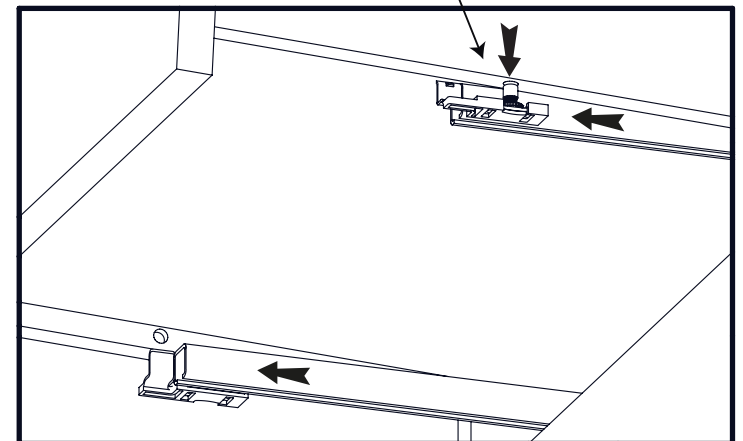
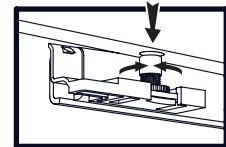
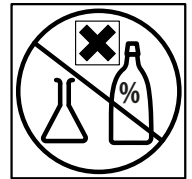
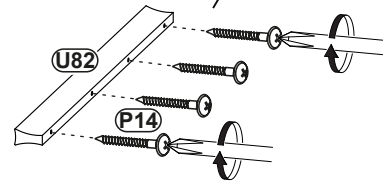
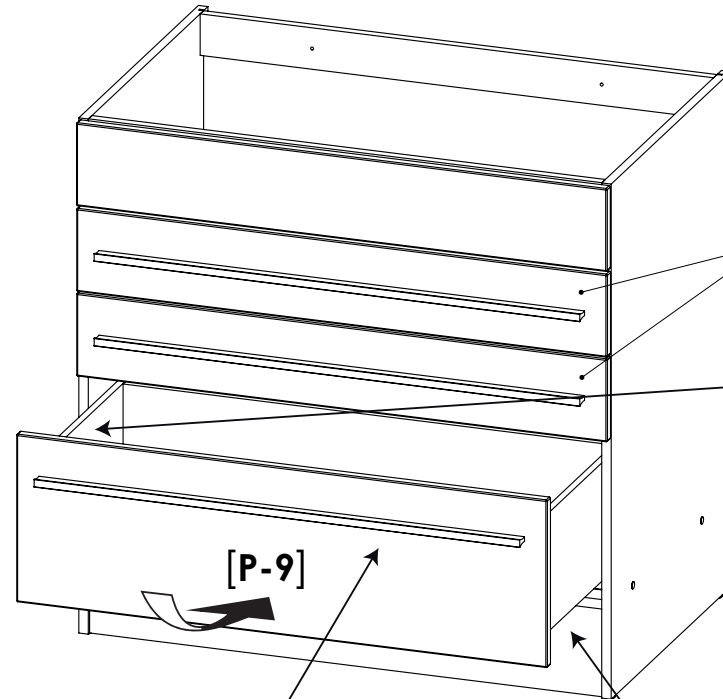

Colli 5/6

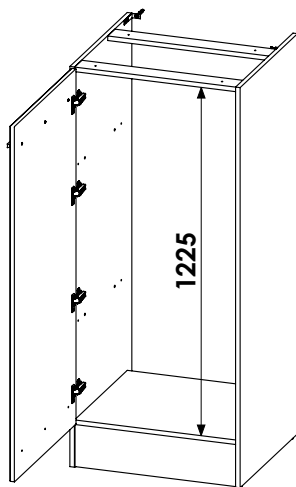
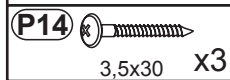
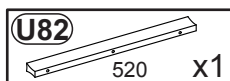
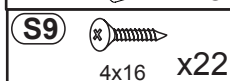
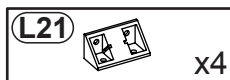
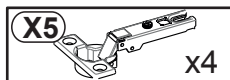
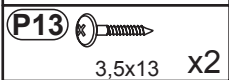
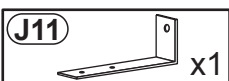
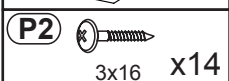
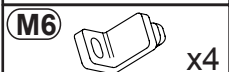
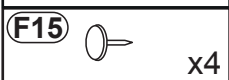
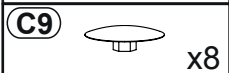
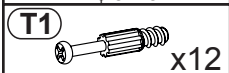
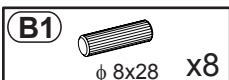

OPTION 1

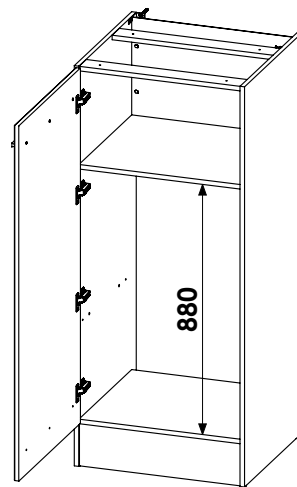

OPTION 2

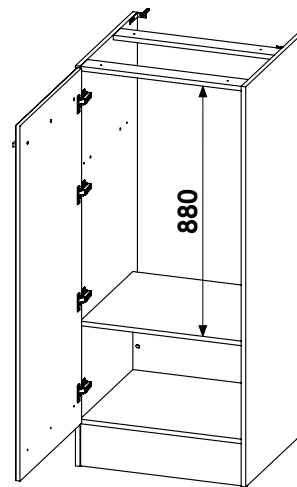

OPTION 3

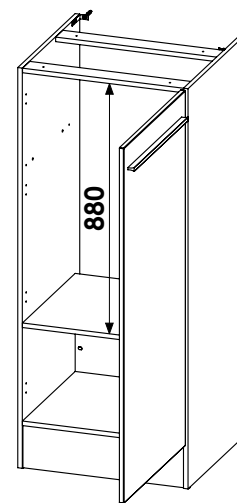
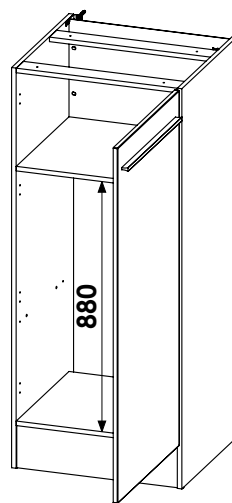
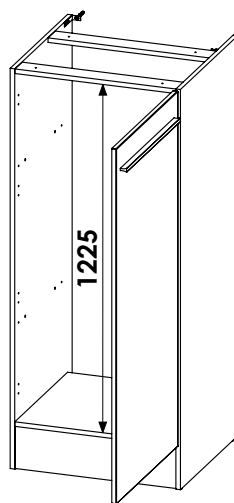

L



R



- 1** **X5**  x4
- S8**  4x13 x8
- D2**  x4
- B1**  ϕ 8x28 x8

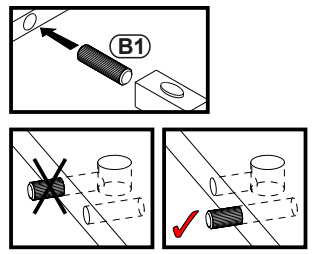
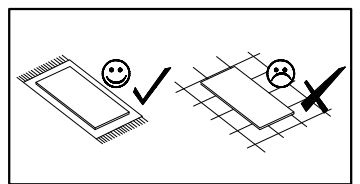
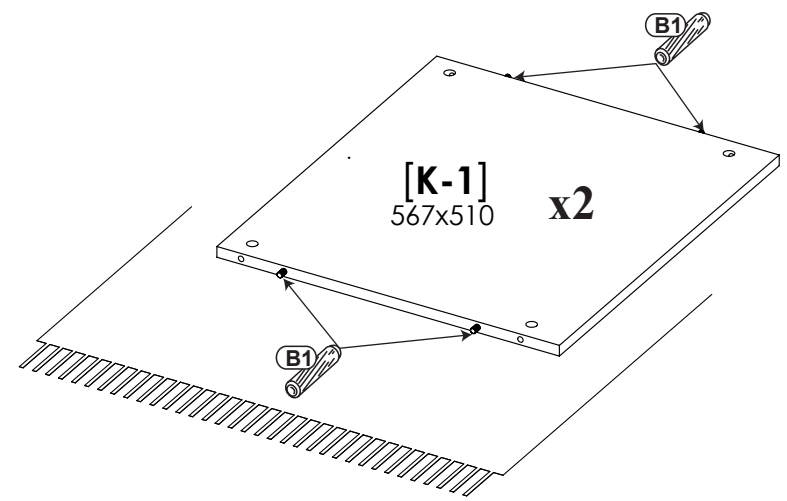
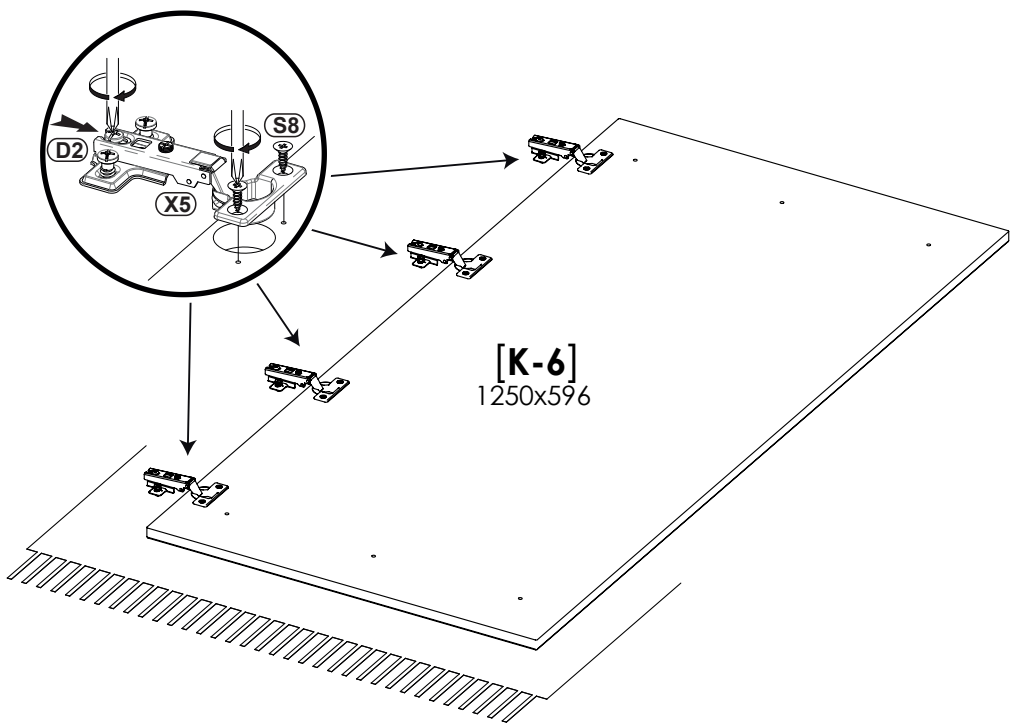

OPTION 1

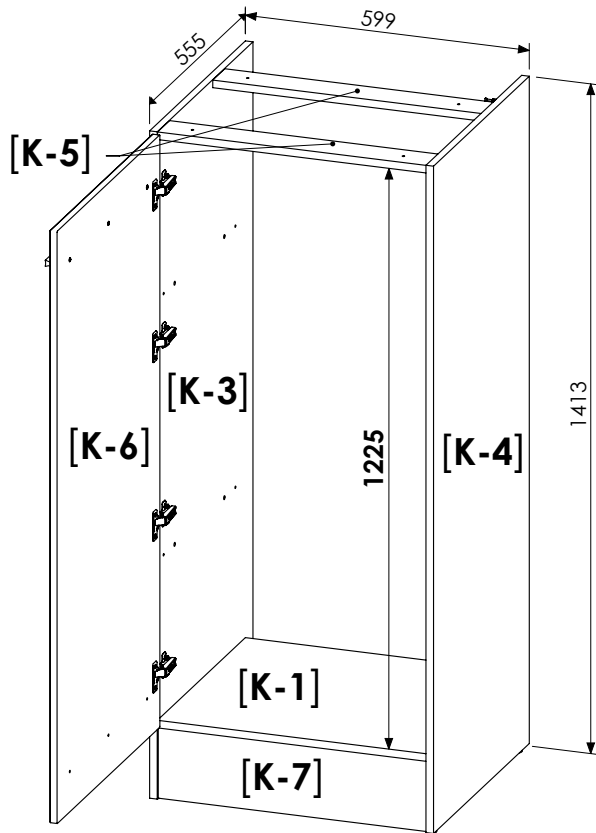

Nr	↔	↕	↗	pcs	
K-1	567	510	16	1	4
K-3	1408	555	16	1	4
K-4	1408	555	16	1	4
K-5	567	70	16	2	4
K-6	1250	596	16	1	4
K-7	567	150	16	1	4

2

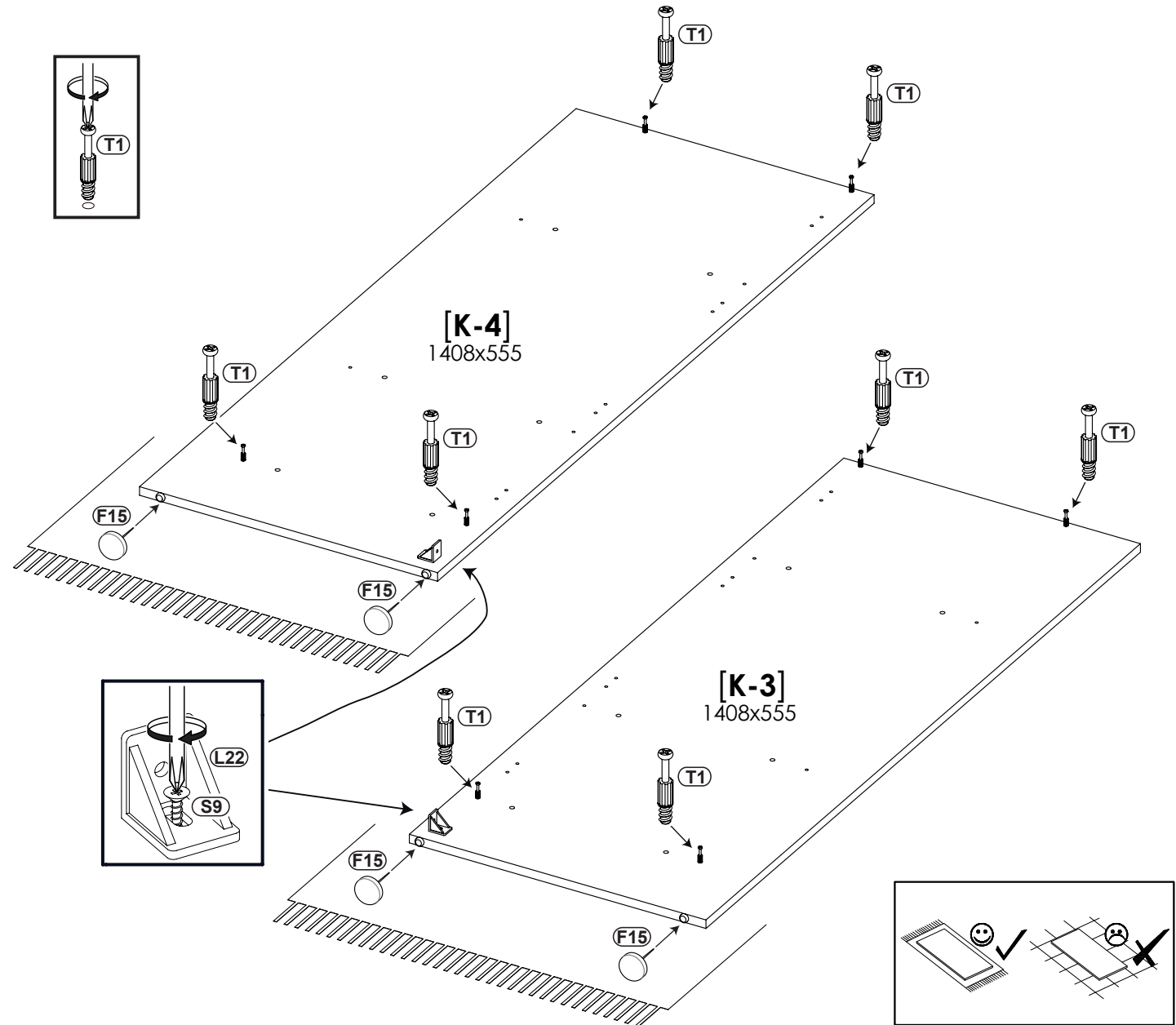
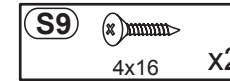
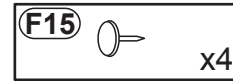
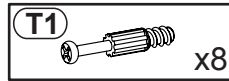

3

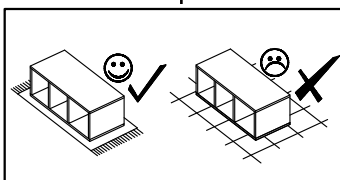
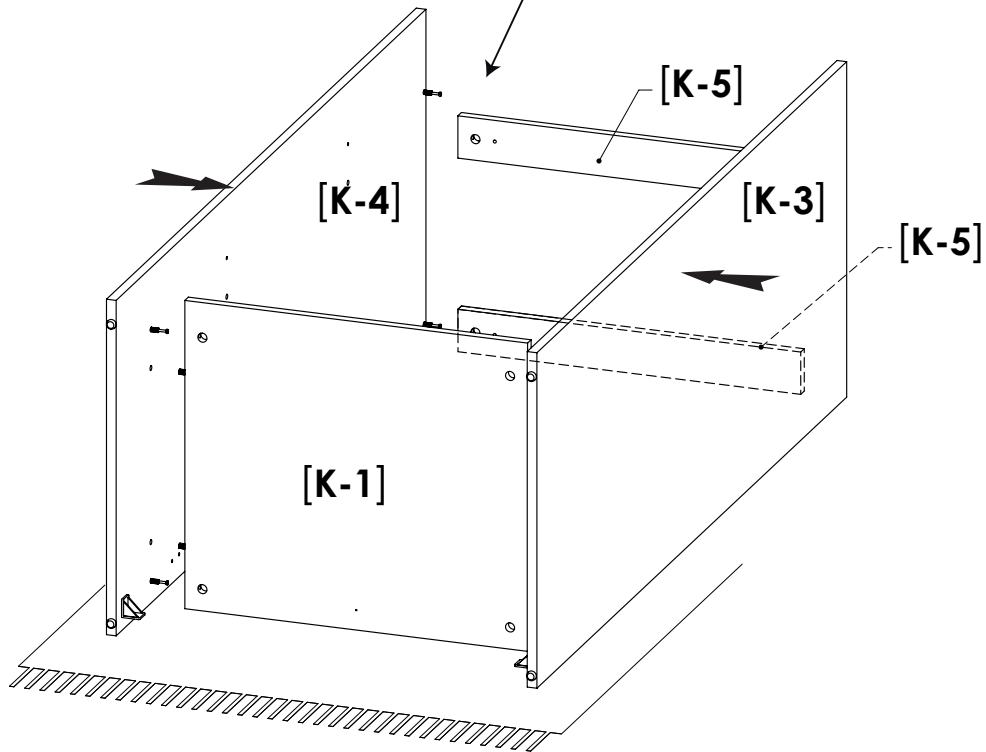
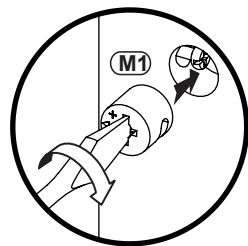

4

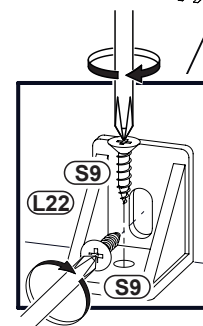
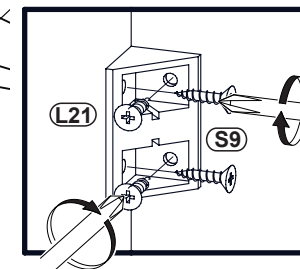
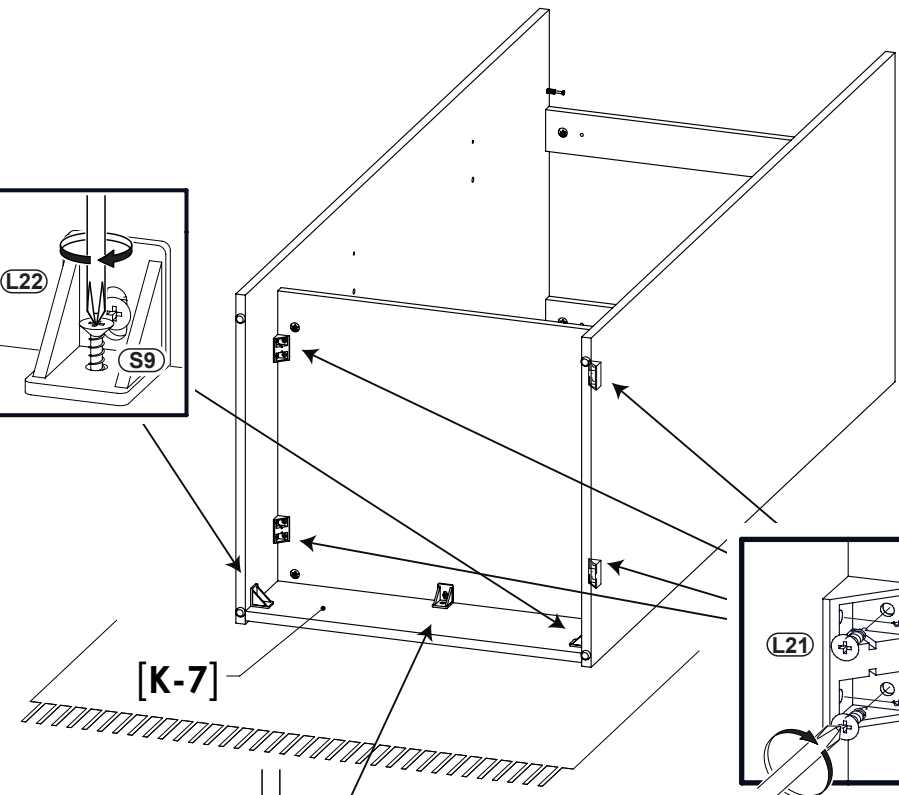
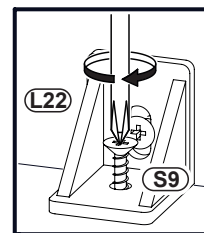
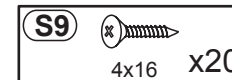
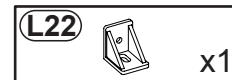
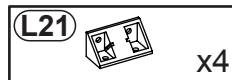

5

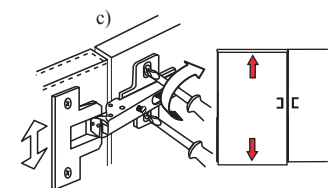
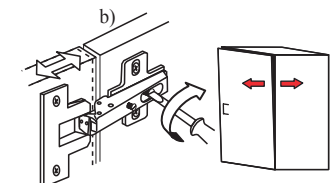
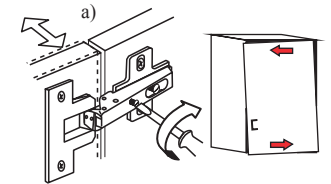
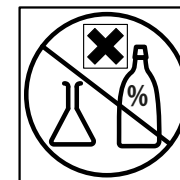
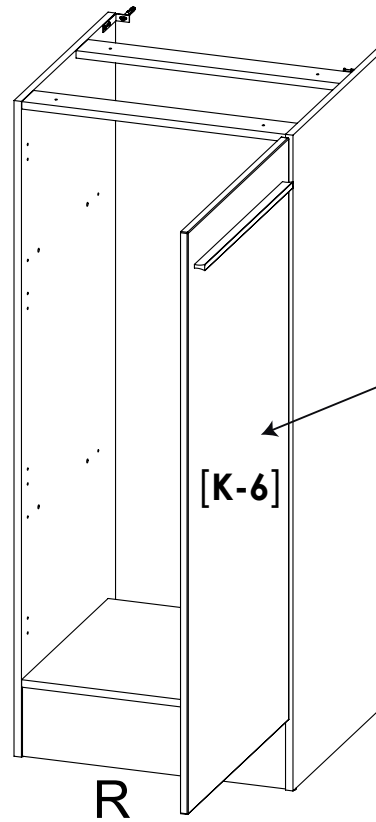
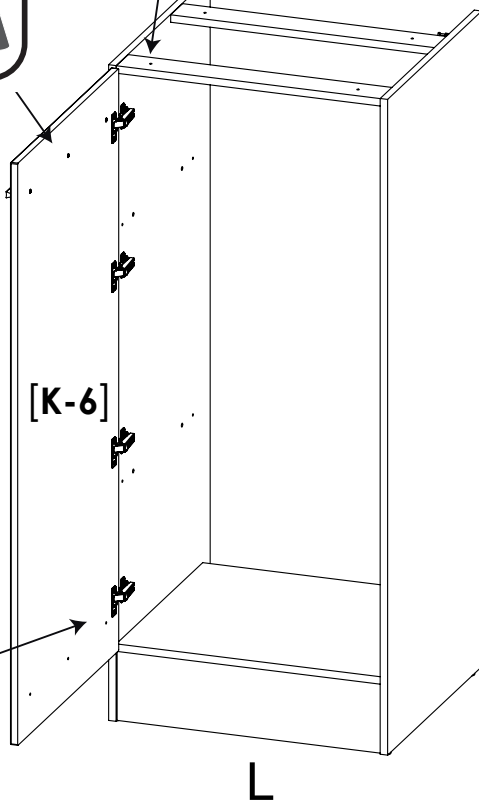
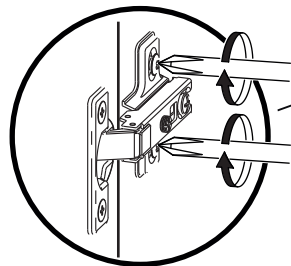
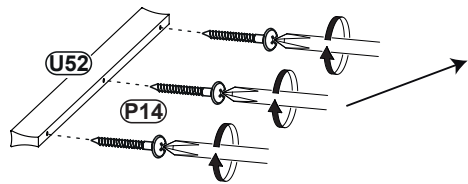
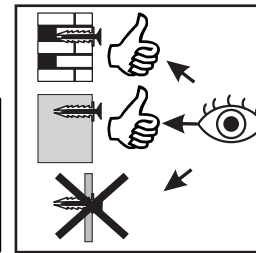
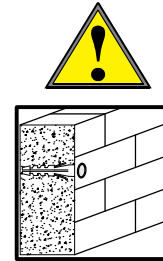
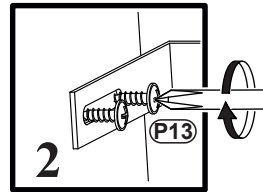
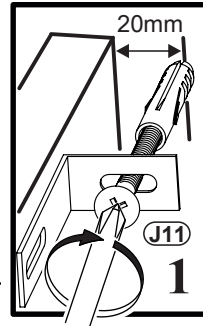
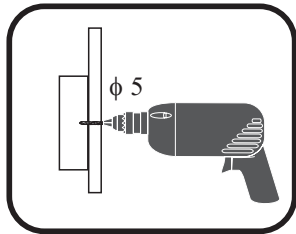
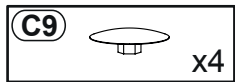
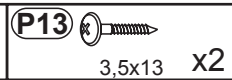
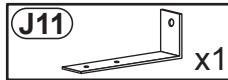
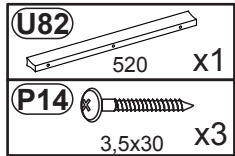

OPTION 2

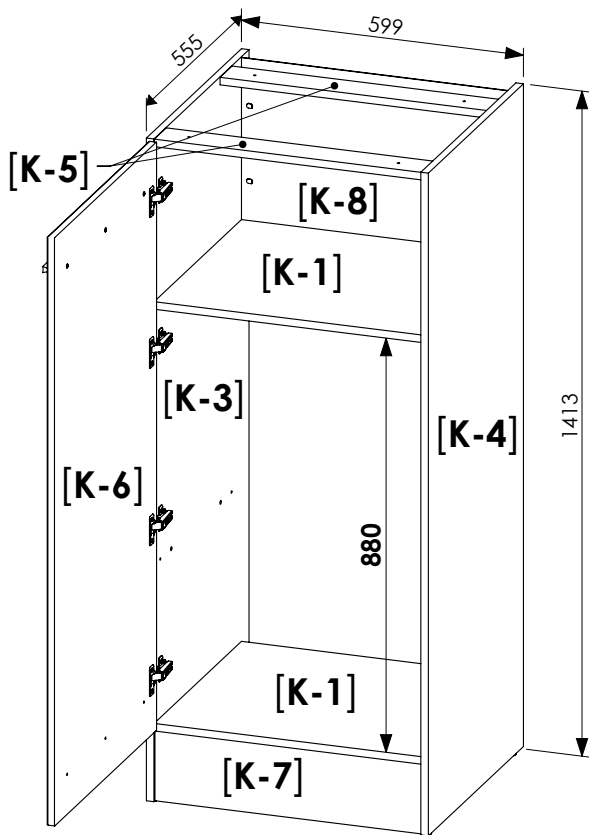

Nr				pcs	
K-1	567	510	16	2	4
K-3	1408	555	16	1	4
K-4	1408	555	16	1	4
K-5	567	70	16	2	4
K-6	1250	596	16	1	4
K-7	567	150	16	1	4
K-8	360	566	2	1	4

2

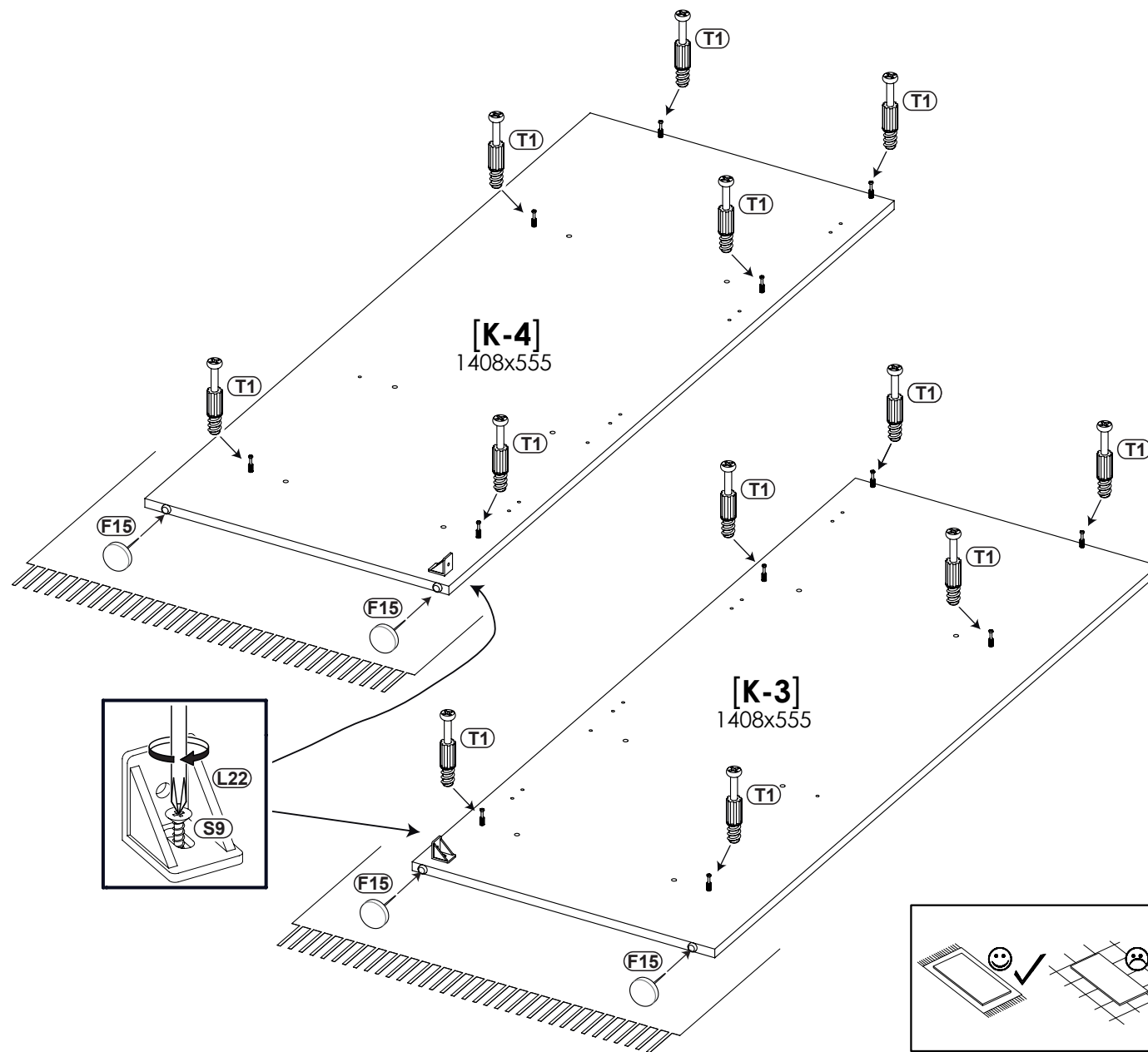
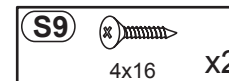
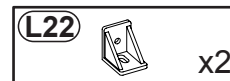
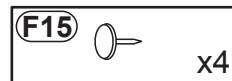
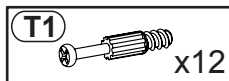

3

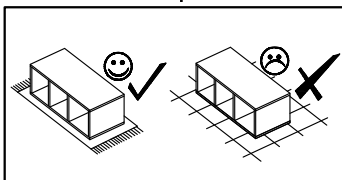
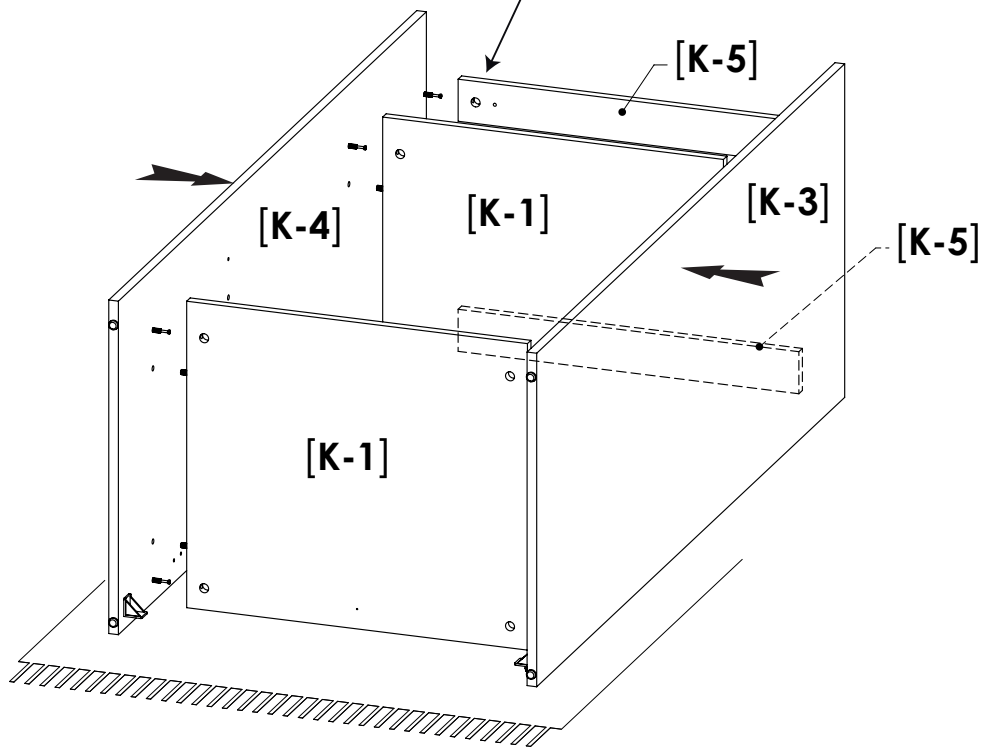
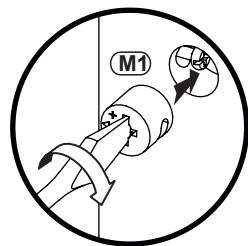

4

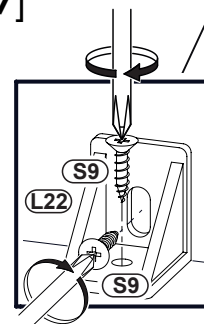
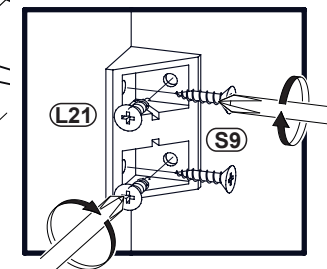
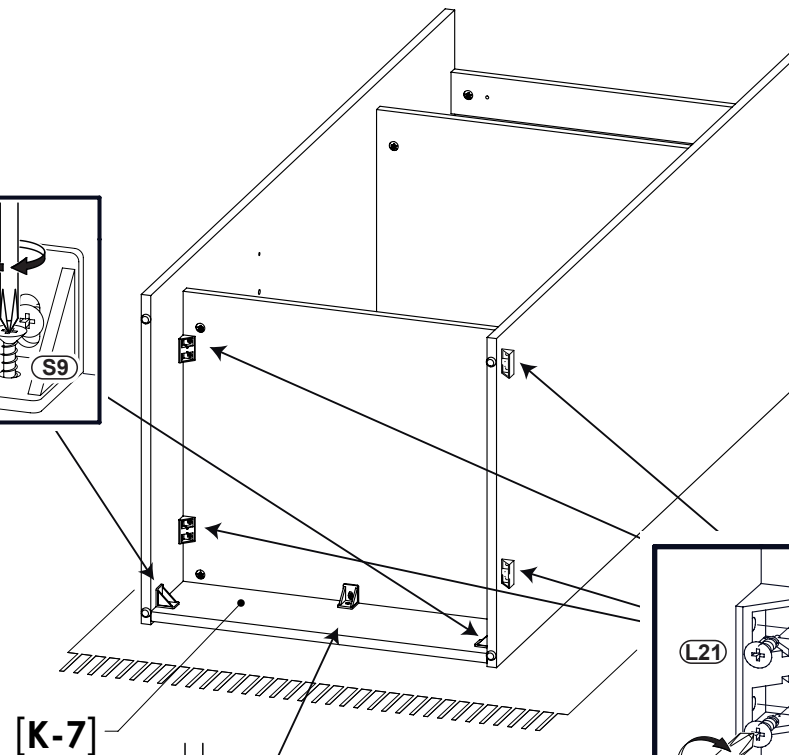
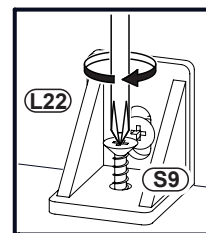
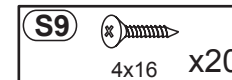
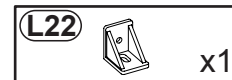
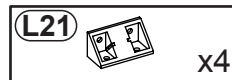

5

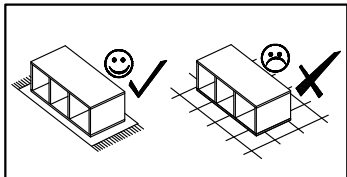
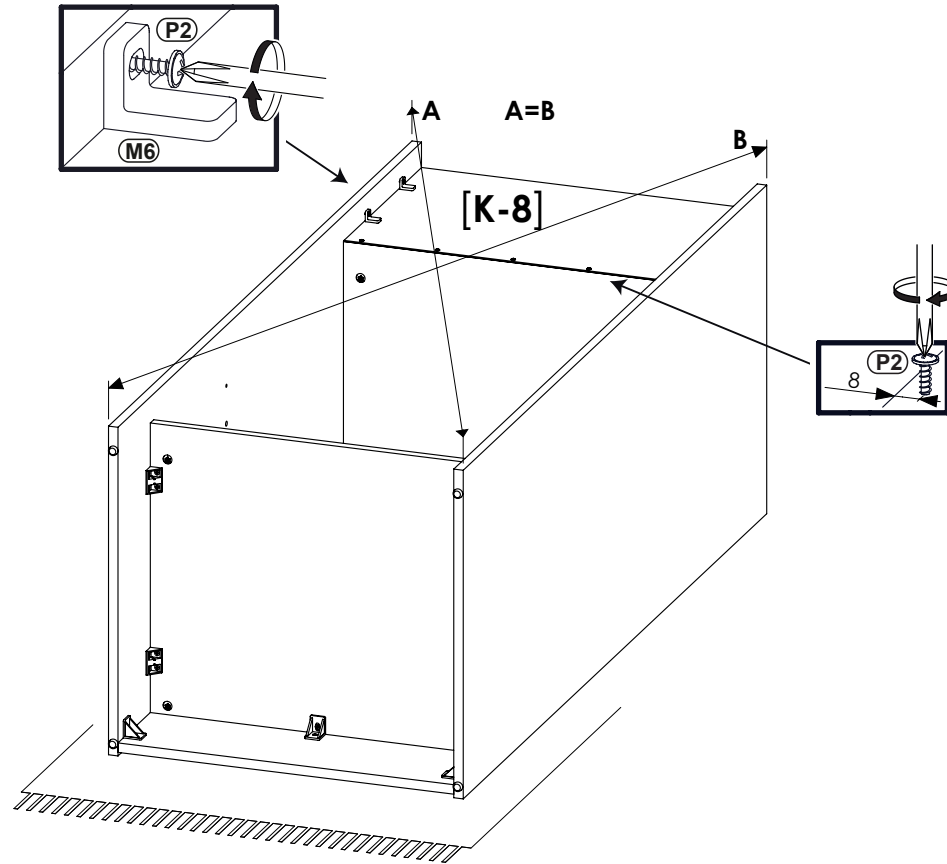
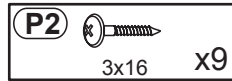
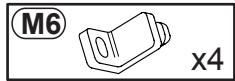

6

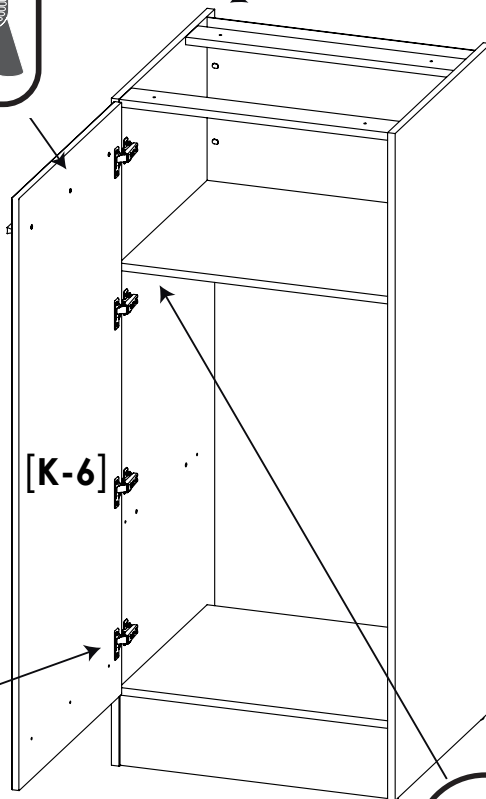
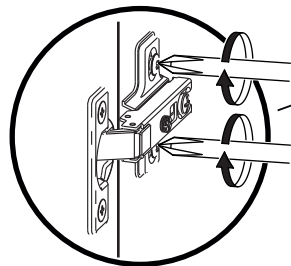
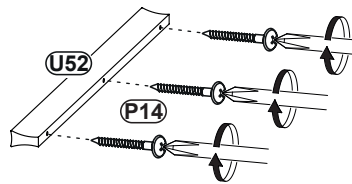
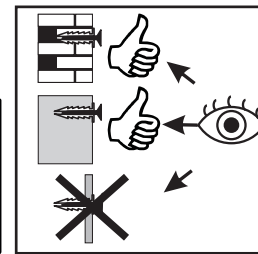
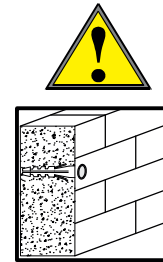
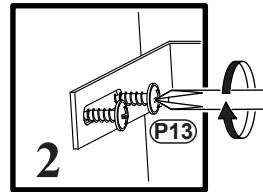
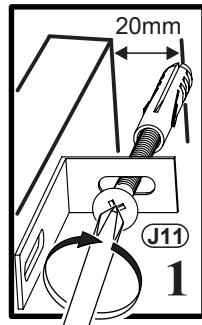
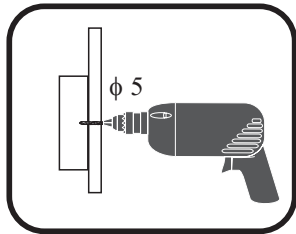
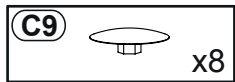
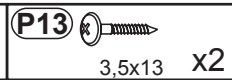
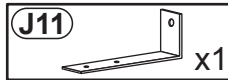
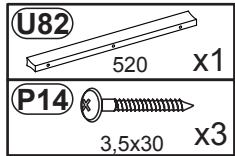

L

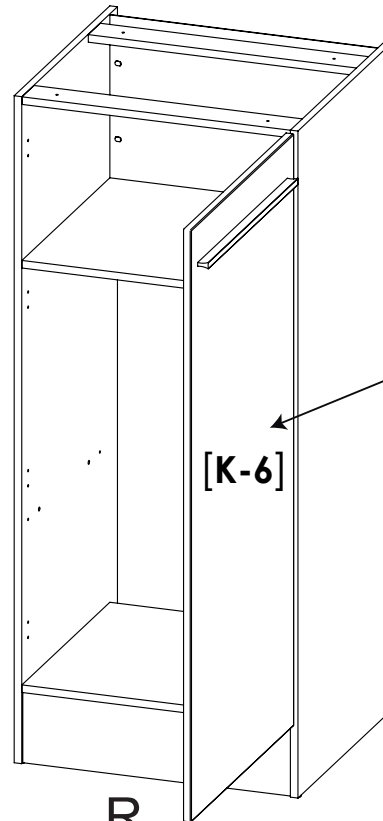
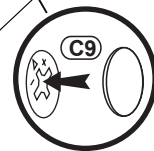

R

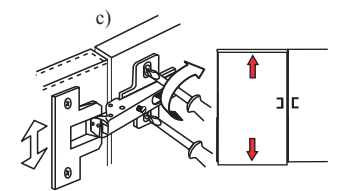
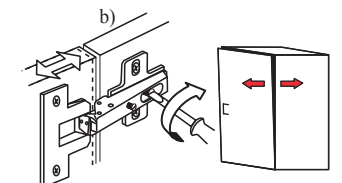
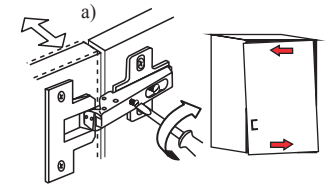
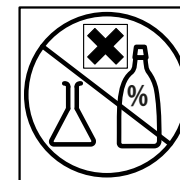

OPTION 3

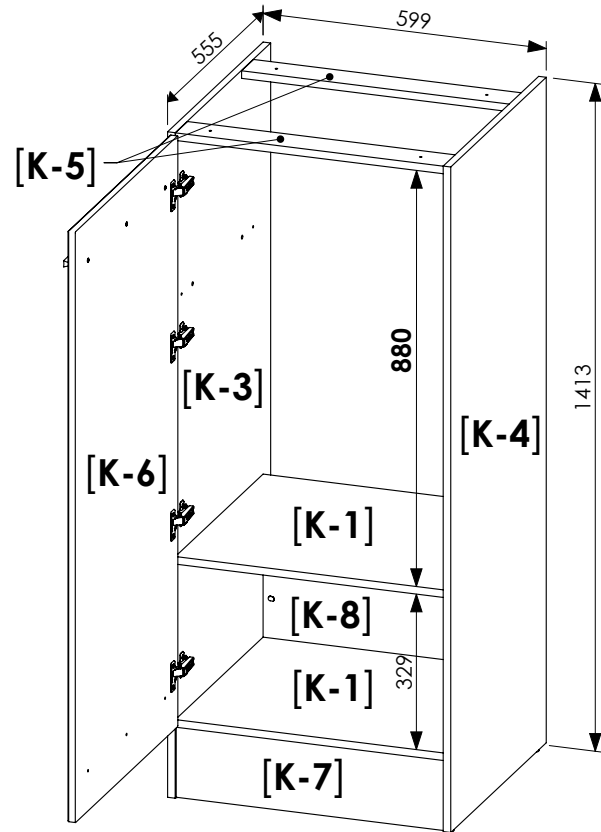

Nr	↔	↑	↗	pcs	
K-1	567	510	16	2	4
K-3	1408	555	16	1	4
K-4	1408	555	16	1	4
K-5	567	70	16	2	4
K-6	1250	596	16	1	4
K-7	567	150	16	1	4
K-8	360	566	2	1	4

2

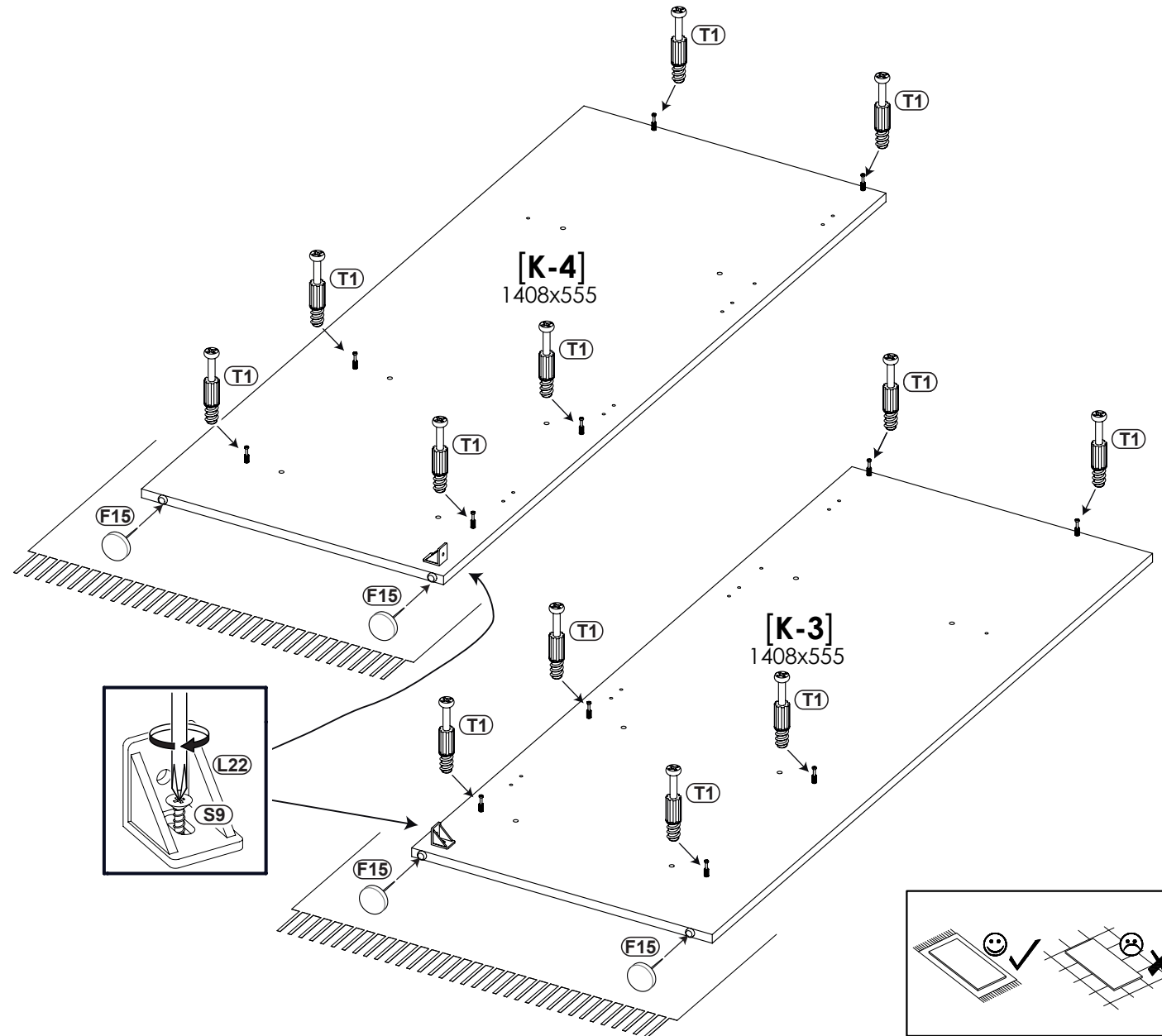
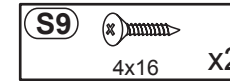
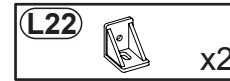
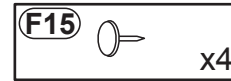
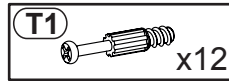

3

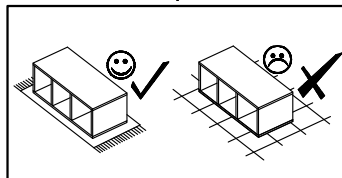
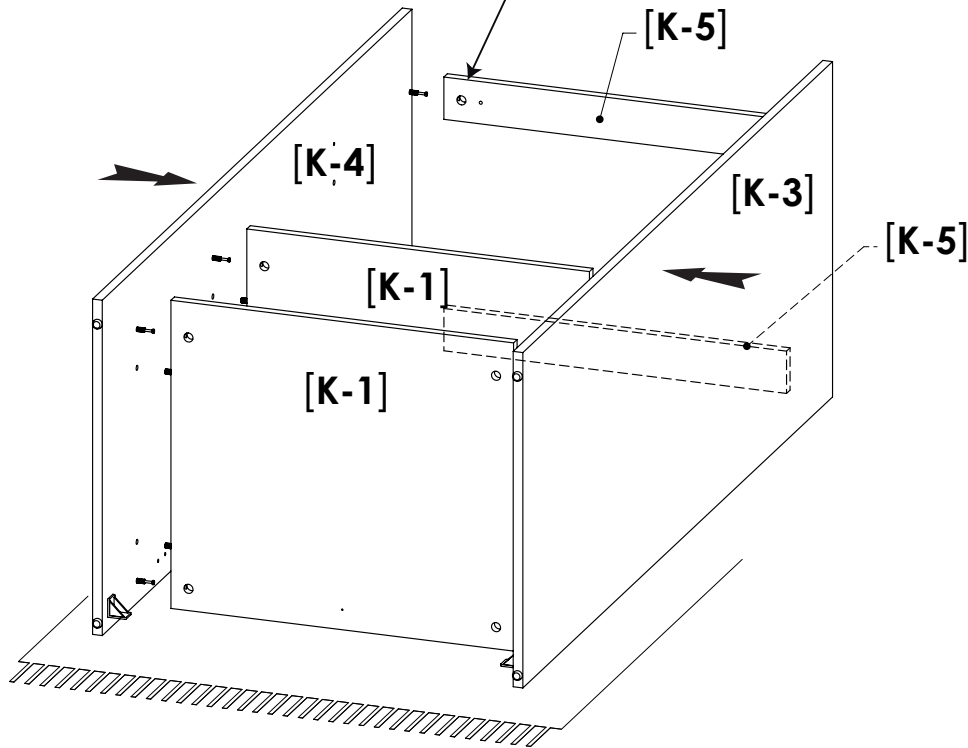
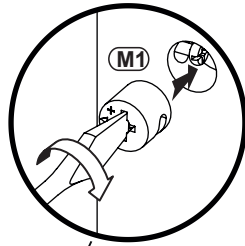

4

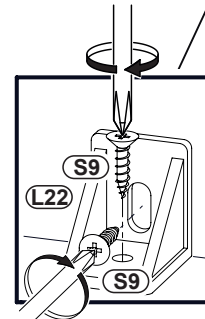
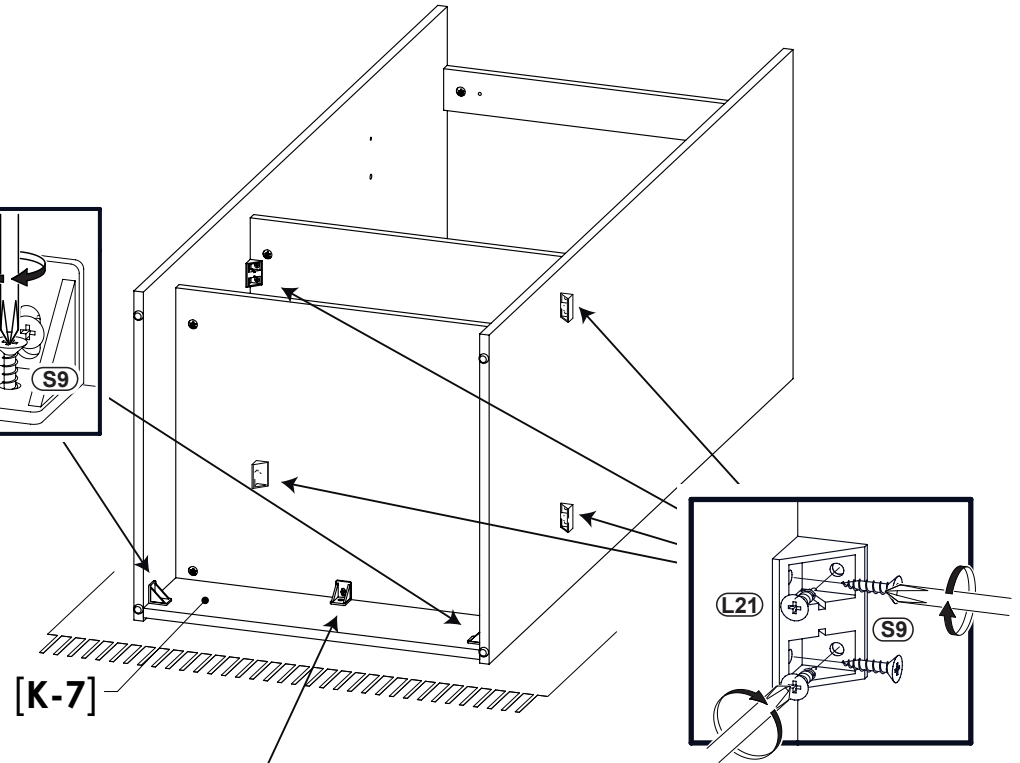
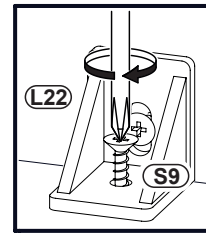
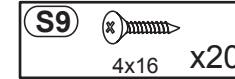
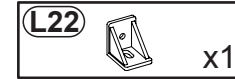
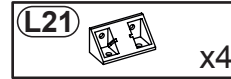

5

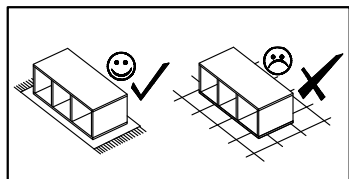
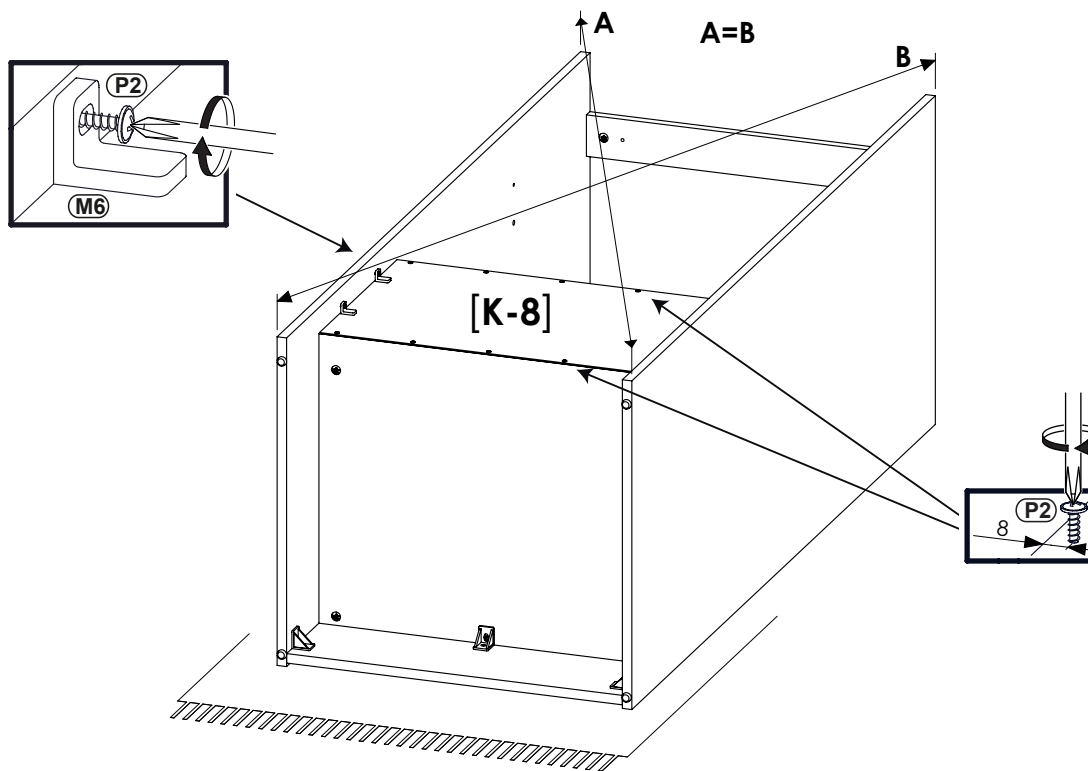
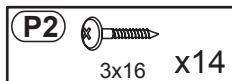
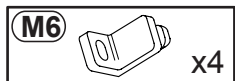



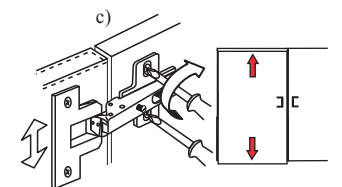
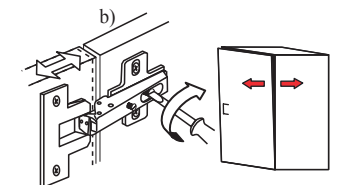
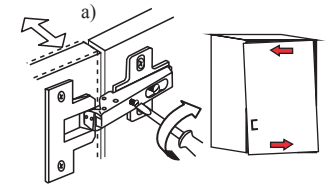
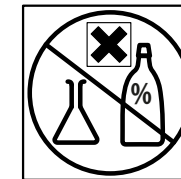
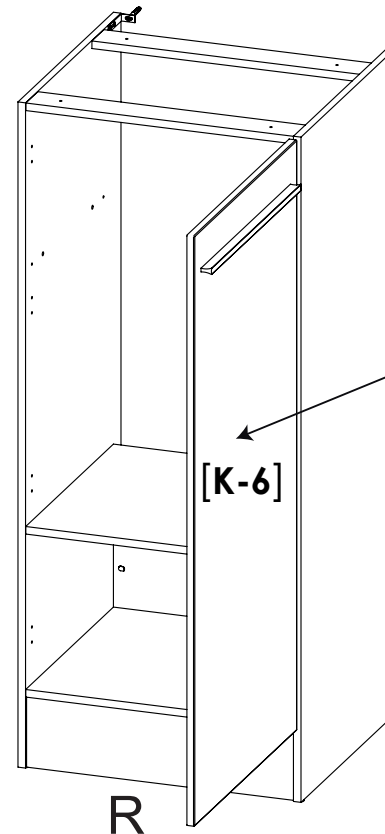
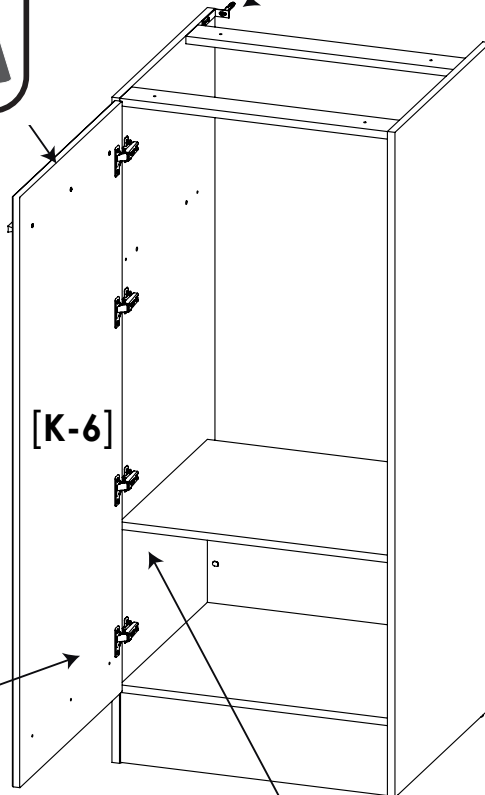
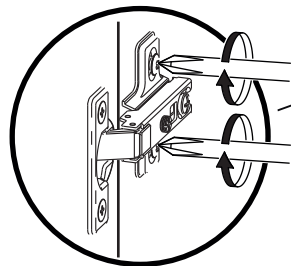
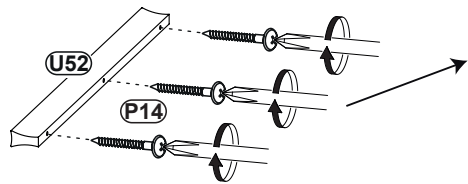
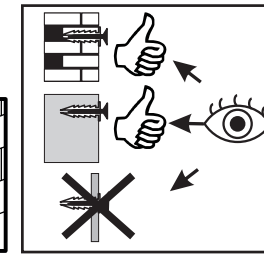
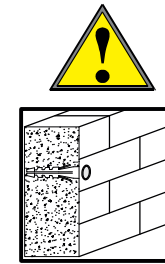
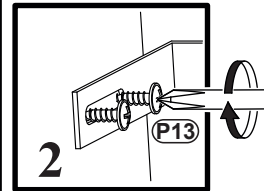
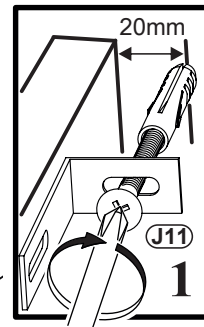
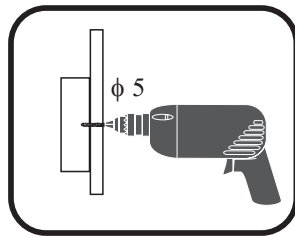
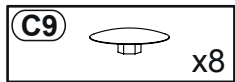
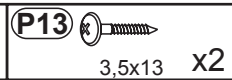
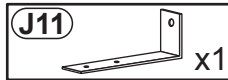
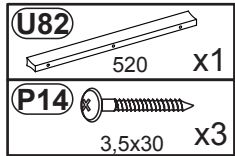

6

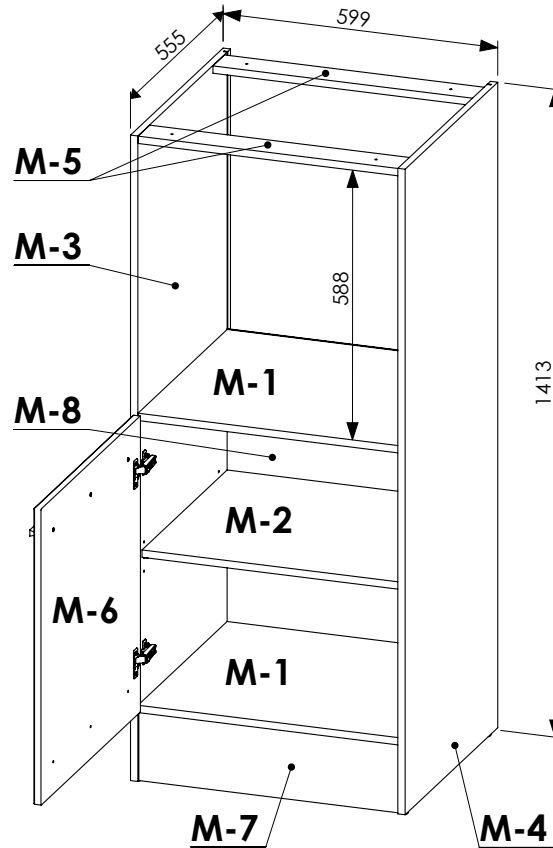
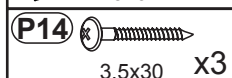
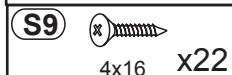
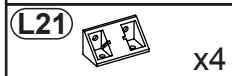
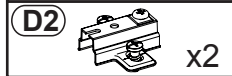
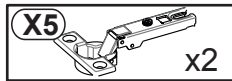
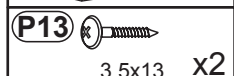
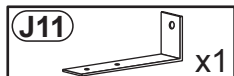
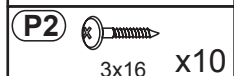
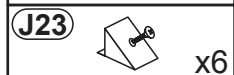
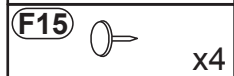
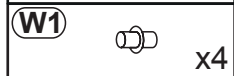
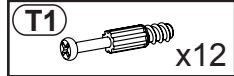
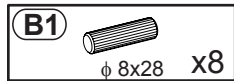

Colli 5/6



Nr				pcs	
M-1	567	534	16	2	3
M-2	567	510	16	1	3
M-3	1408	555	16	1	3
M-4	1408	555	16	1	3
M-5	567	70	16	2	3
M-6	646	596	16	1	3
M-7	567	150	16	1	3
M-8	654	581	2	1	3

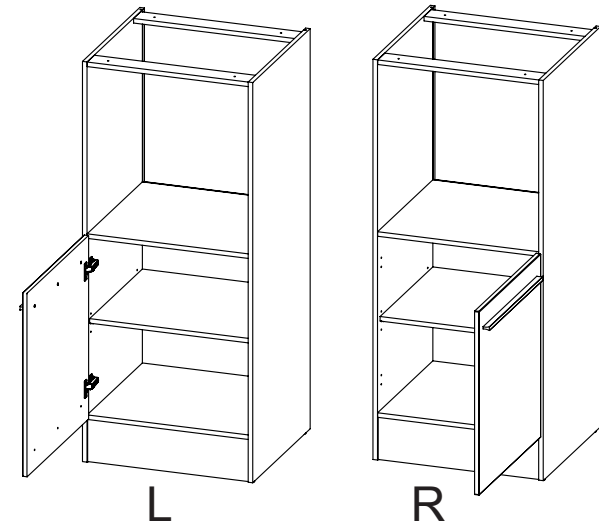

1

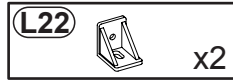
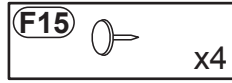
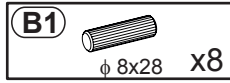
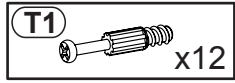

2

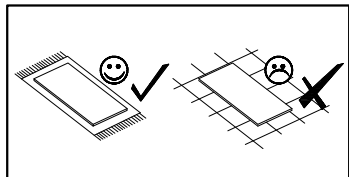
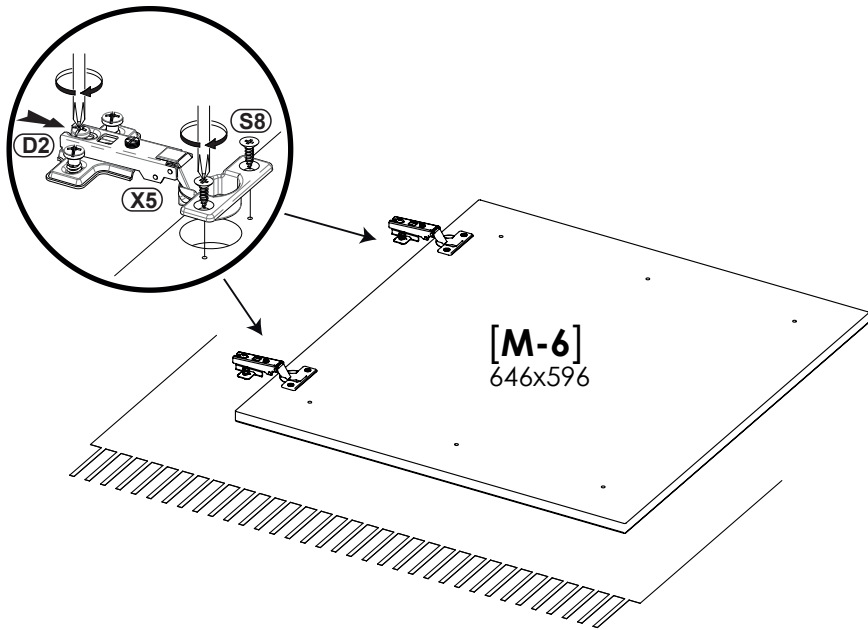
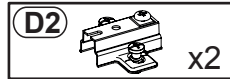
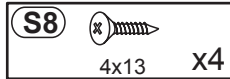
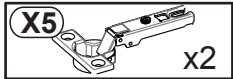

3

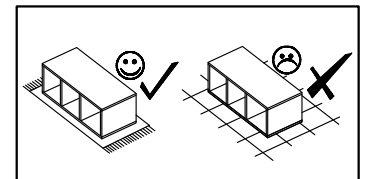
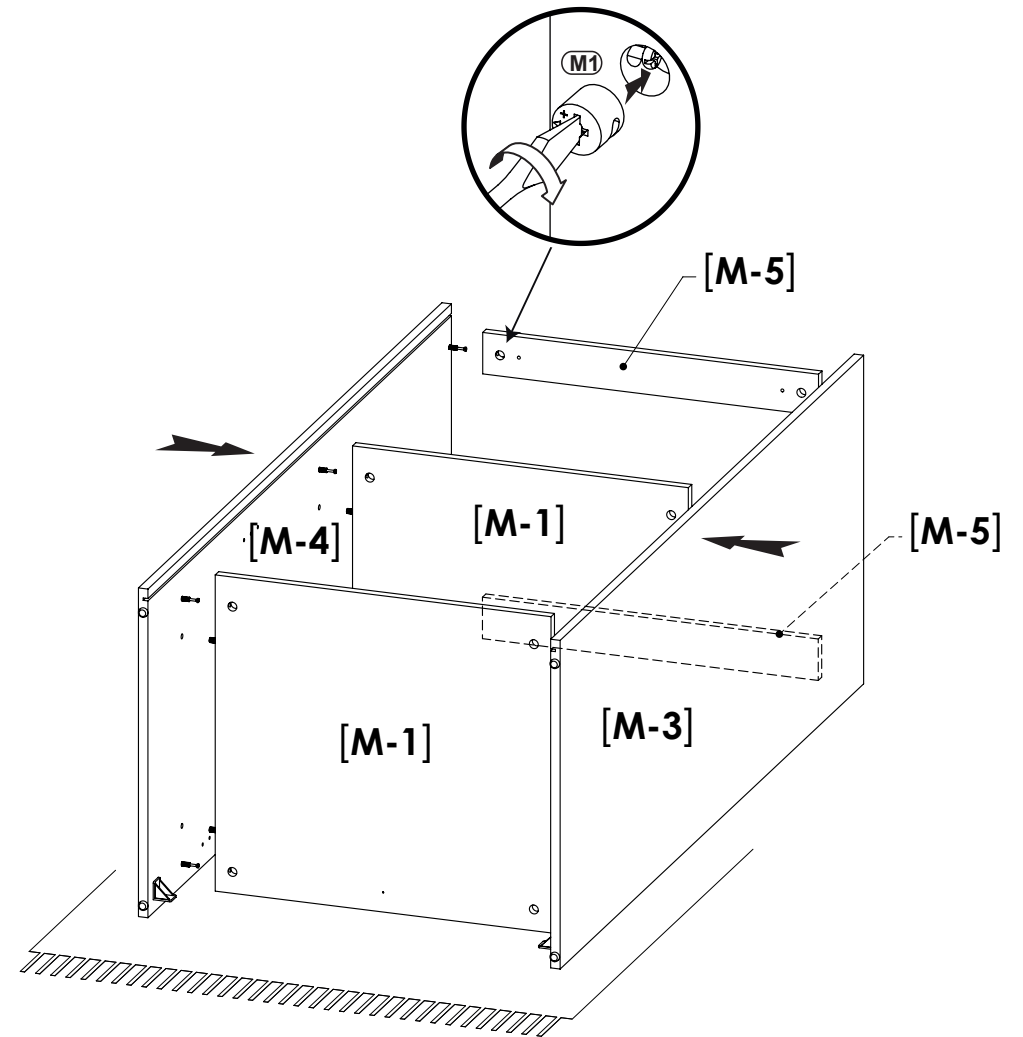

4

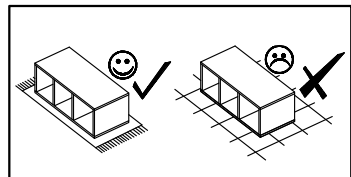
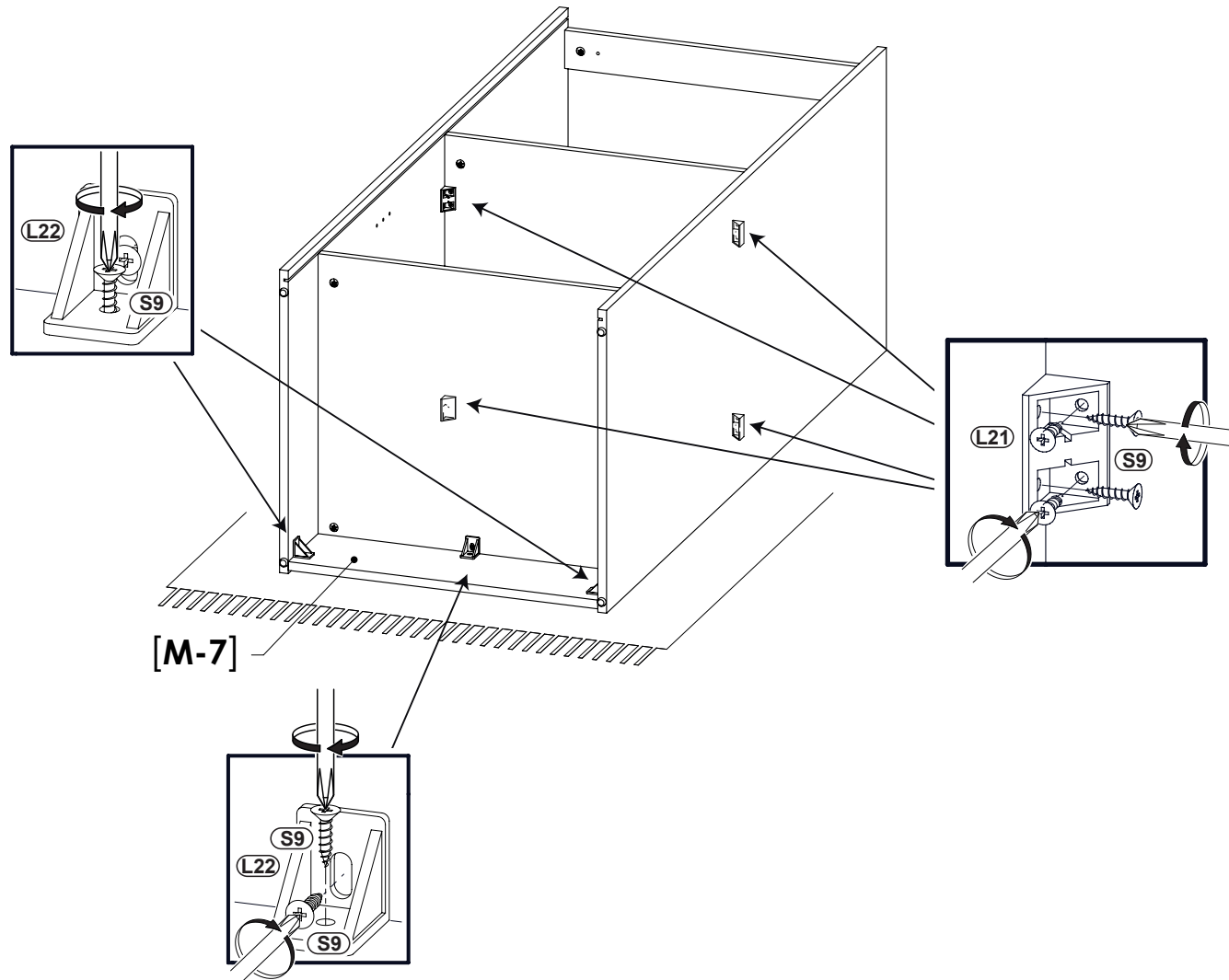
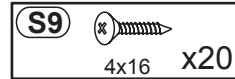
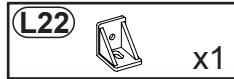
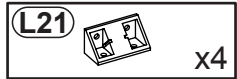

7

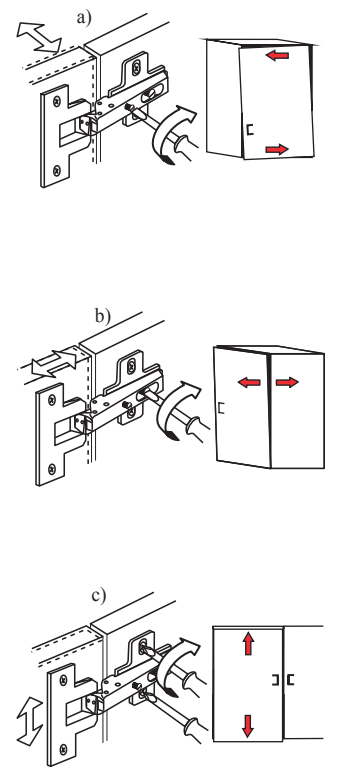
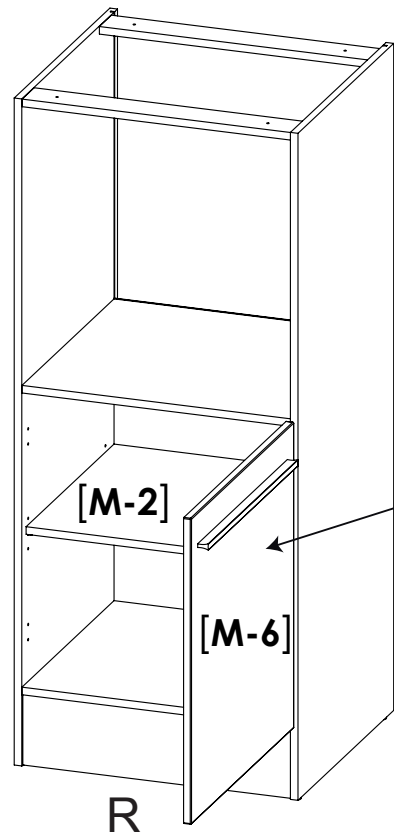
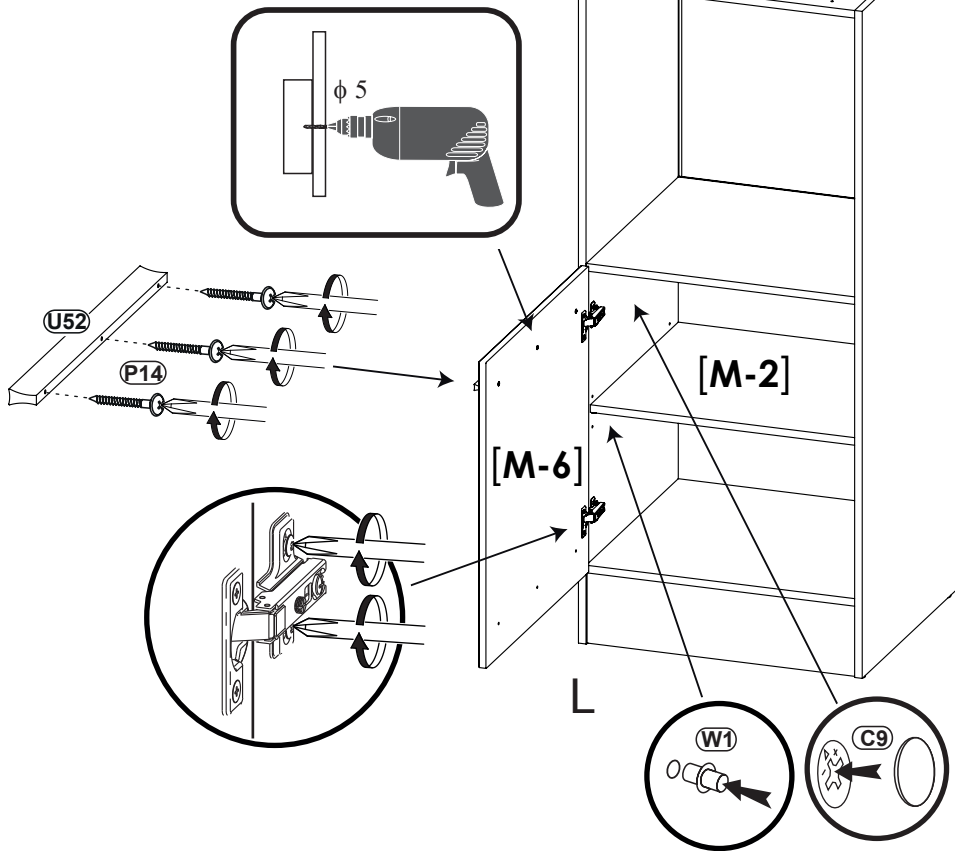
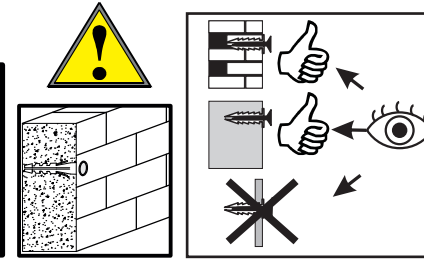
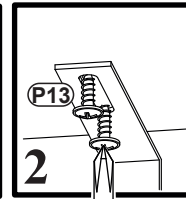
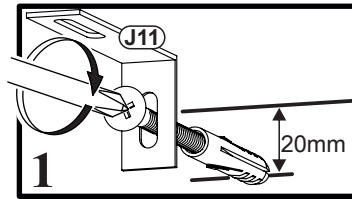
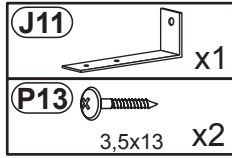
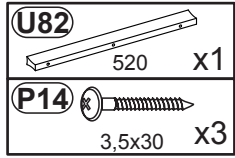

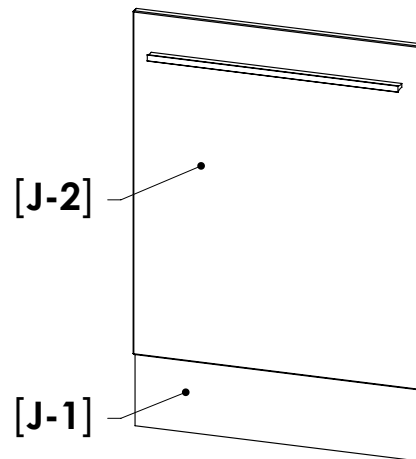
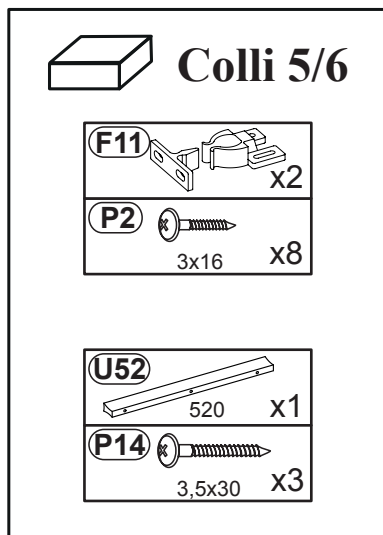

Nr				pcs	
J-1	600	150	16	1	3
J-2	713	596	16	1	3



1

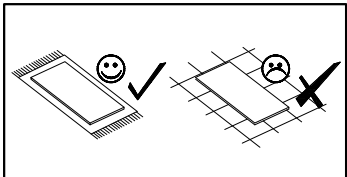
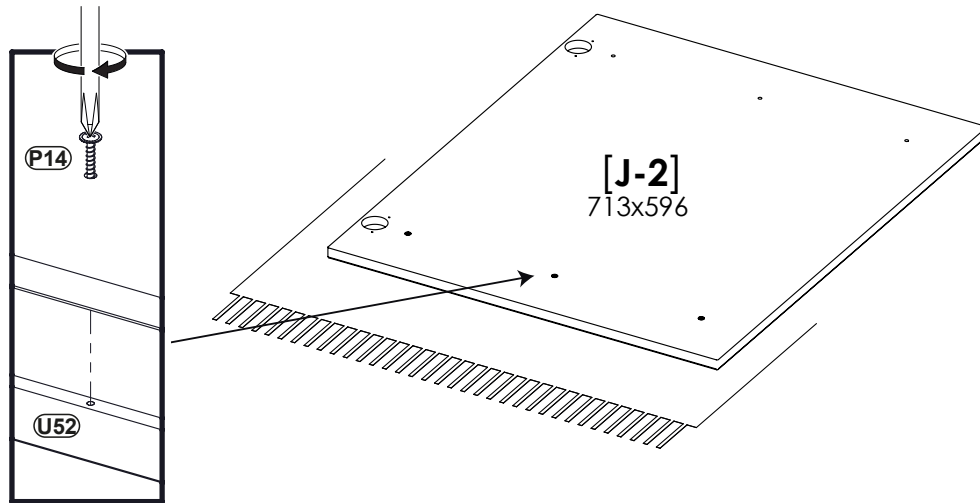
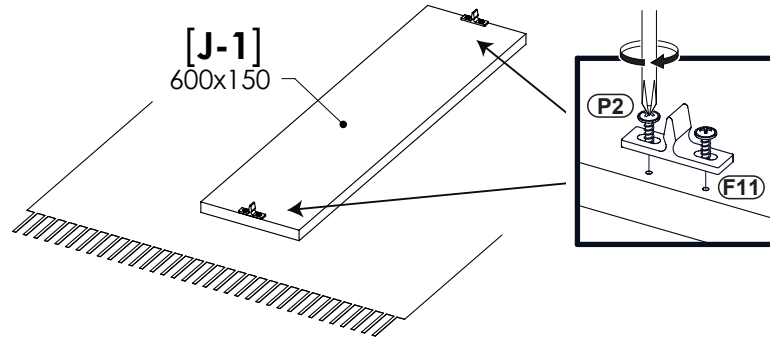



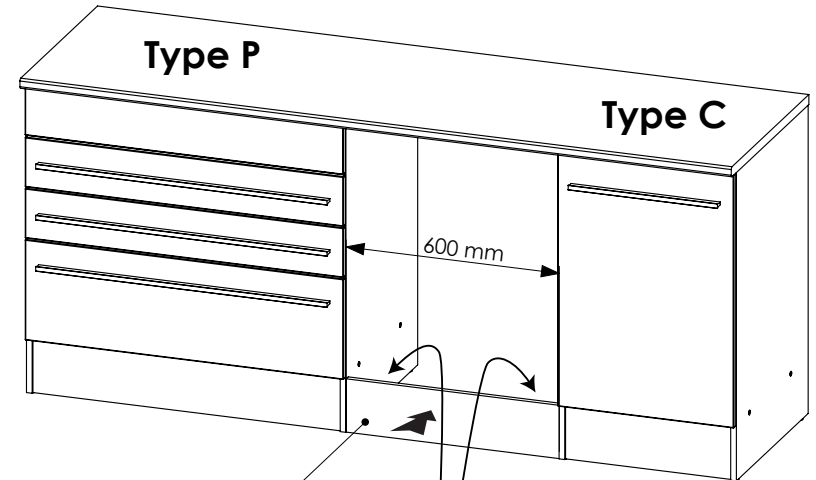
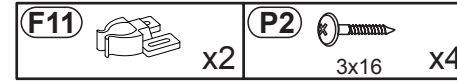

2

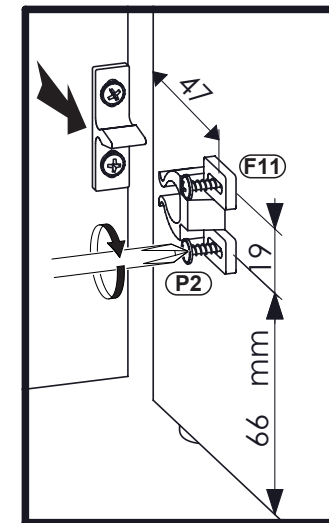

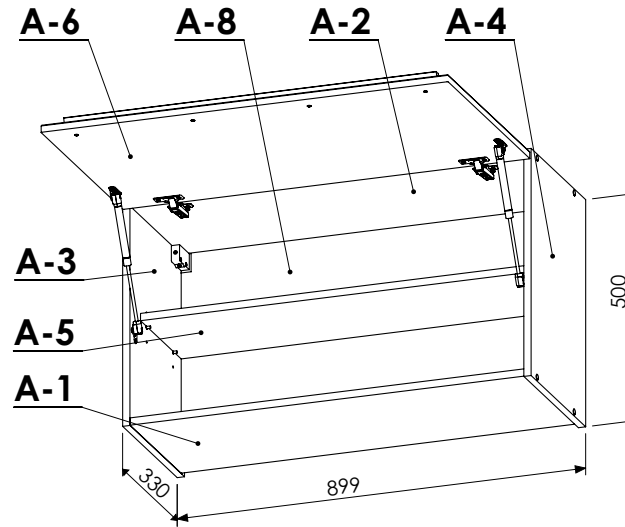
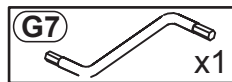
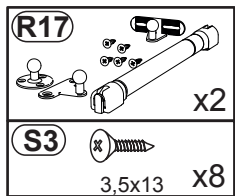
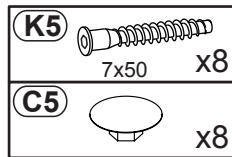
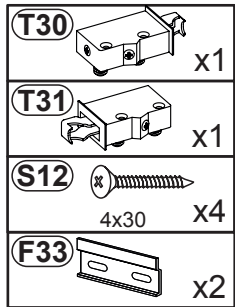
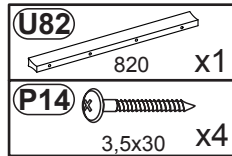
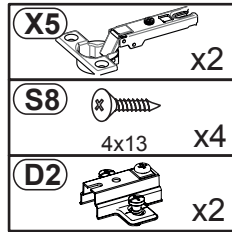
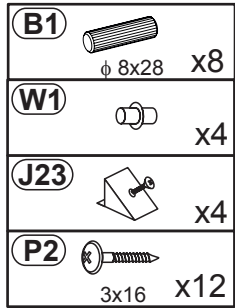
[J-1]





Nr				pcs	
A-1	867	309	16	1	5
A-2	867	309	16	1	5
A-3	500	330	16	1	5
A-4	500	330	16	1	5
A-5	867	246	16	1	5
A-6	896	496	16	1	5
A-8	495	881	2	1	5



1

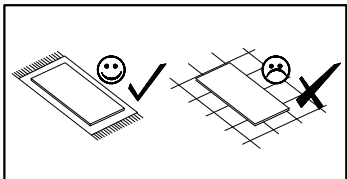
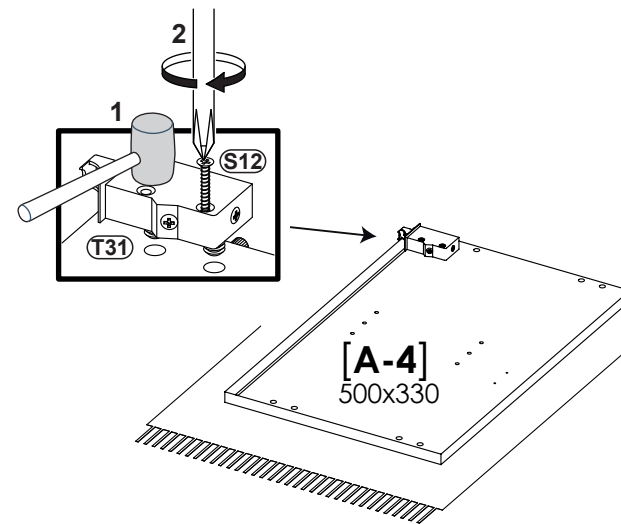
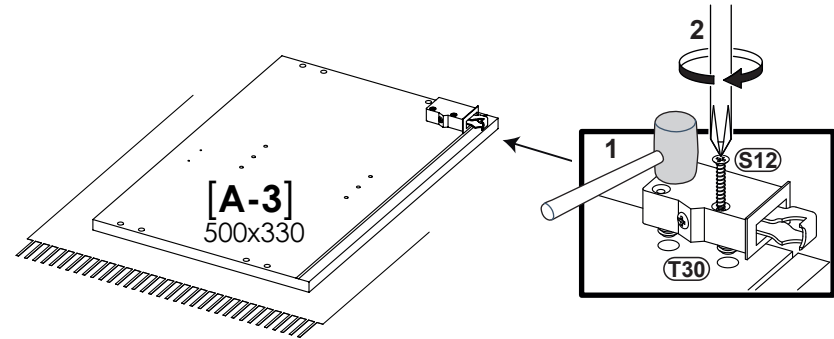
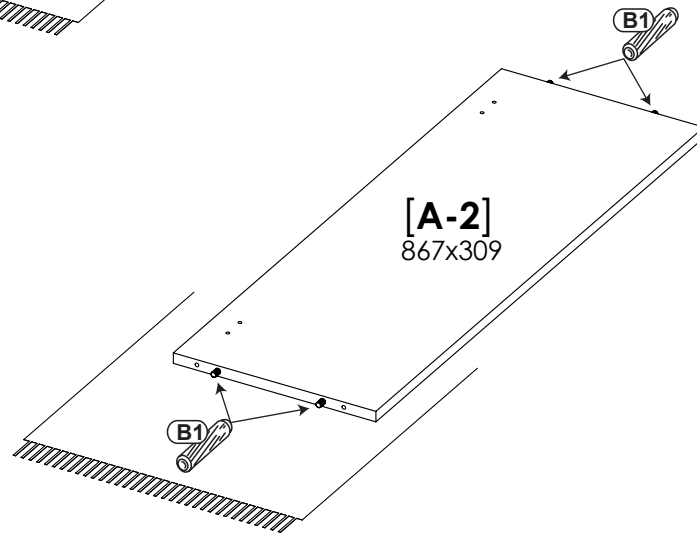
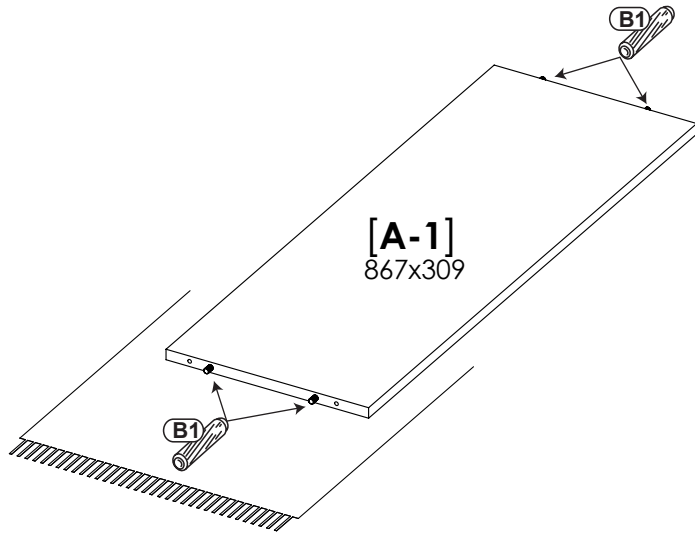
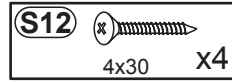
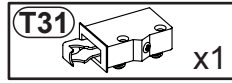
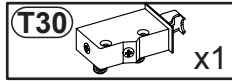
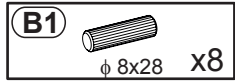

2

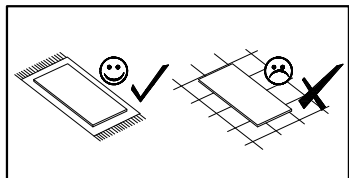
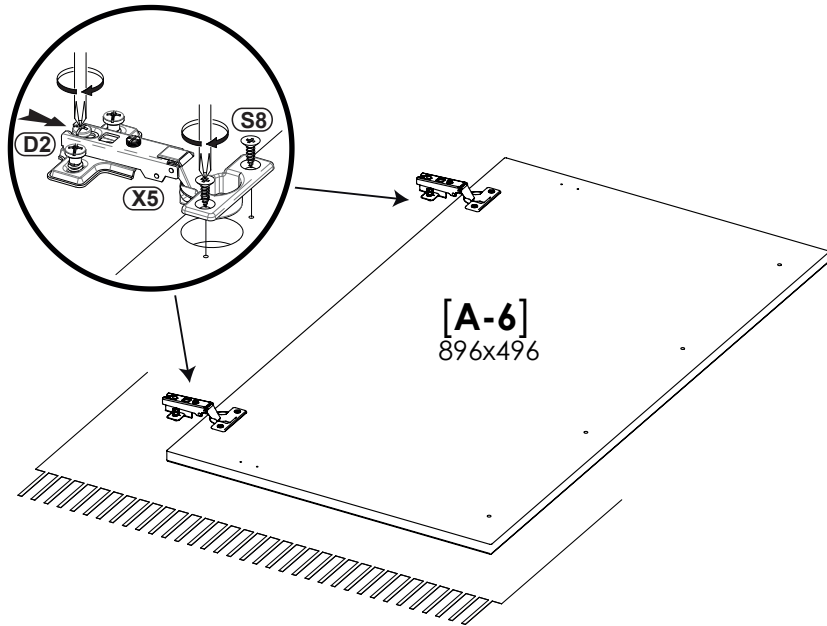
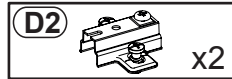
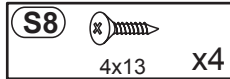
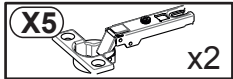

3

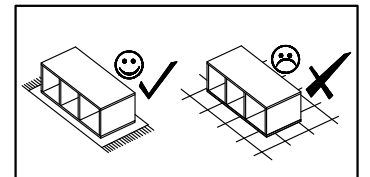
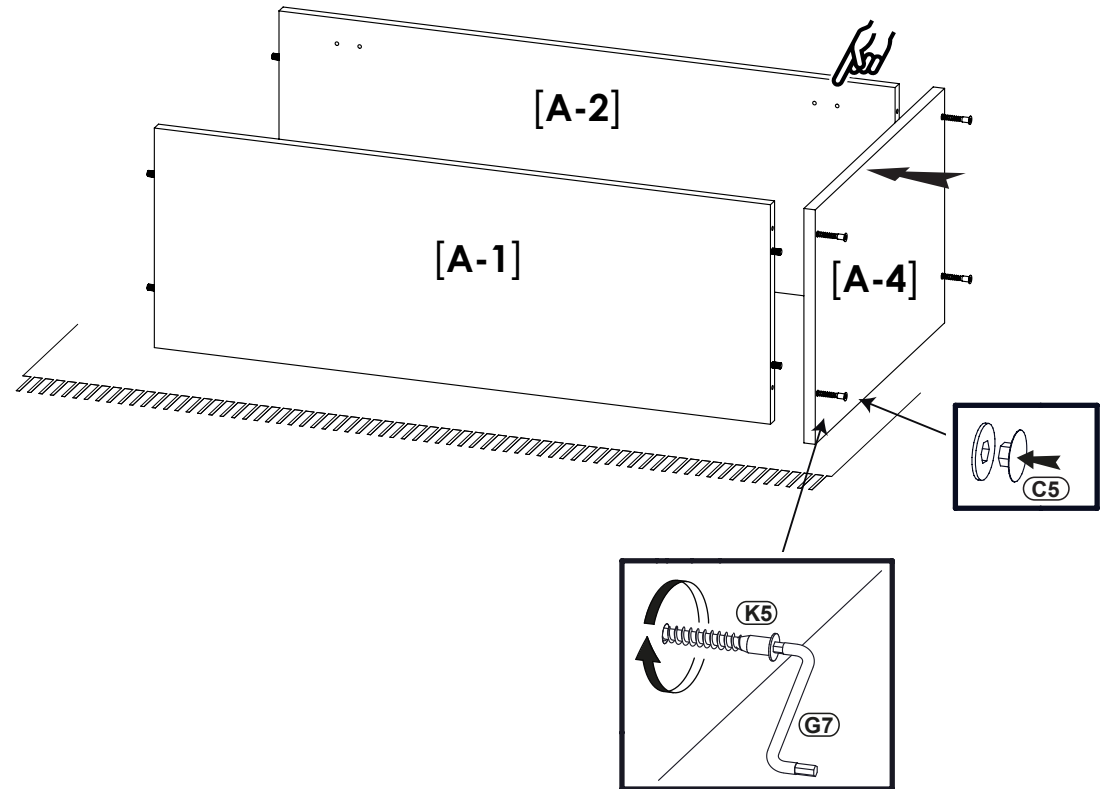
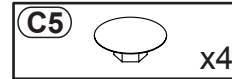
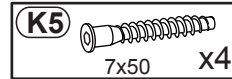

4

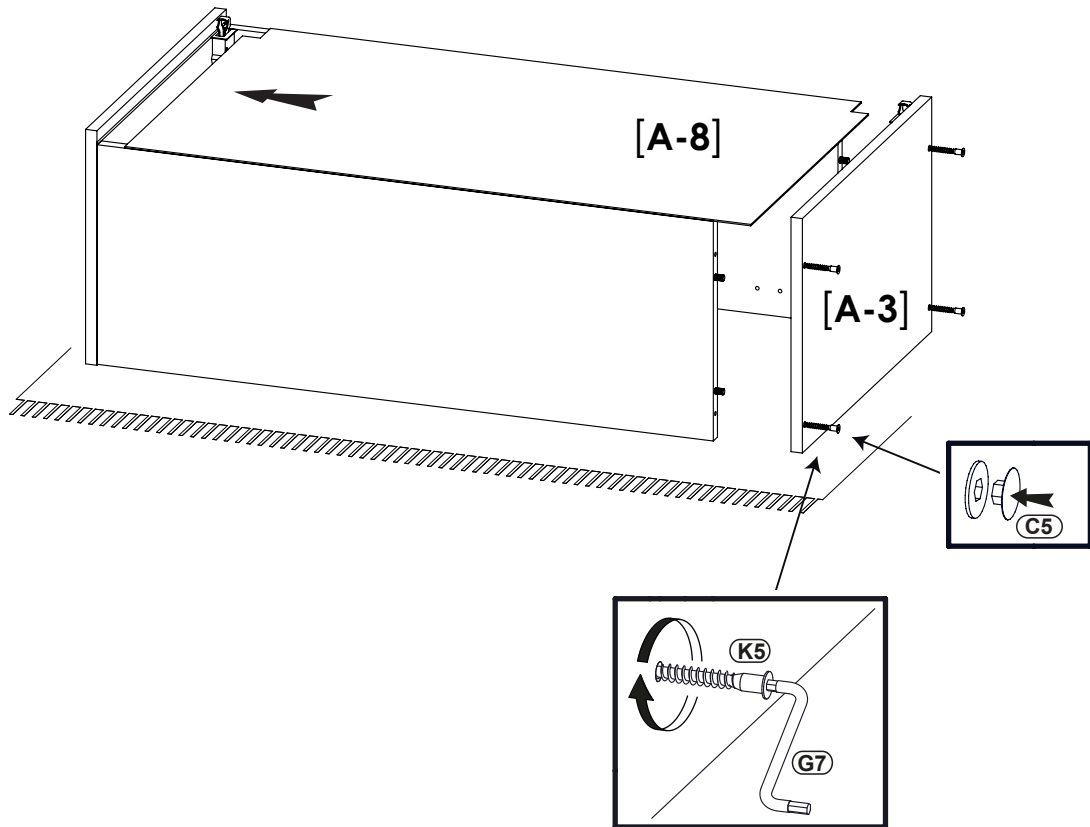
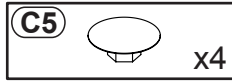
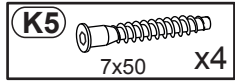

5

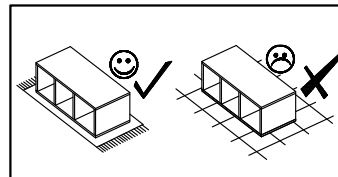
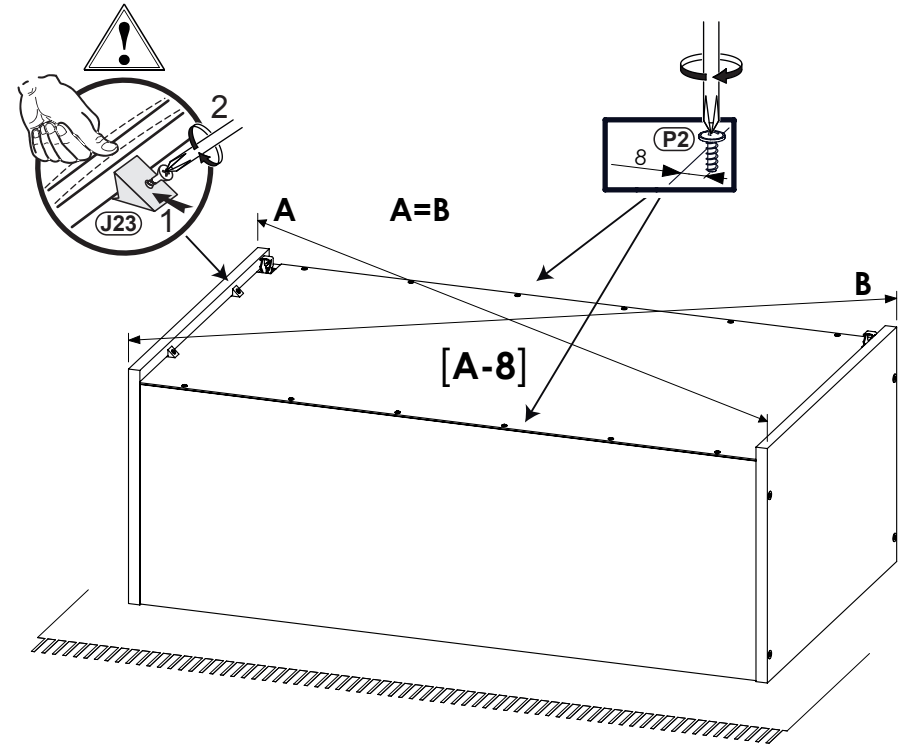
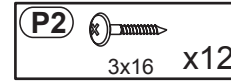
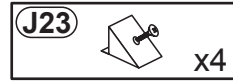



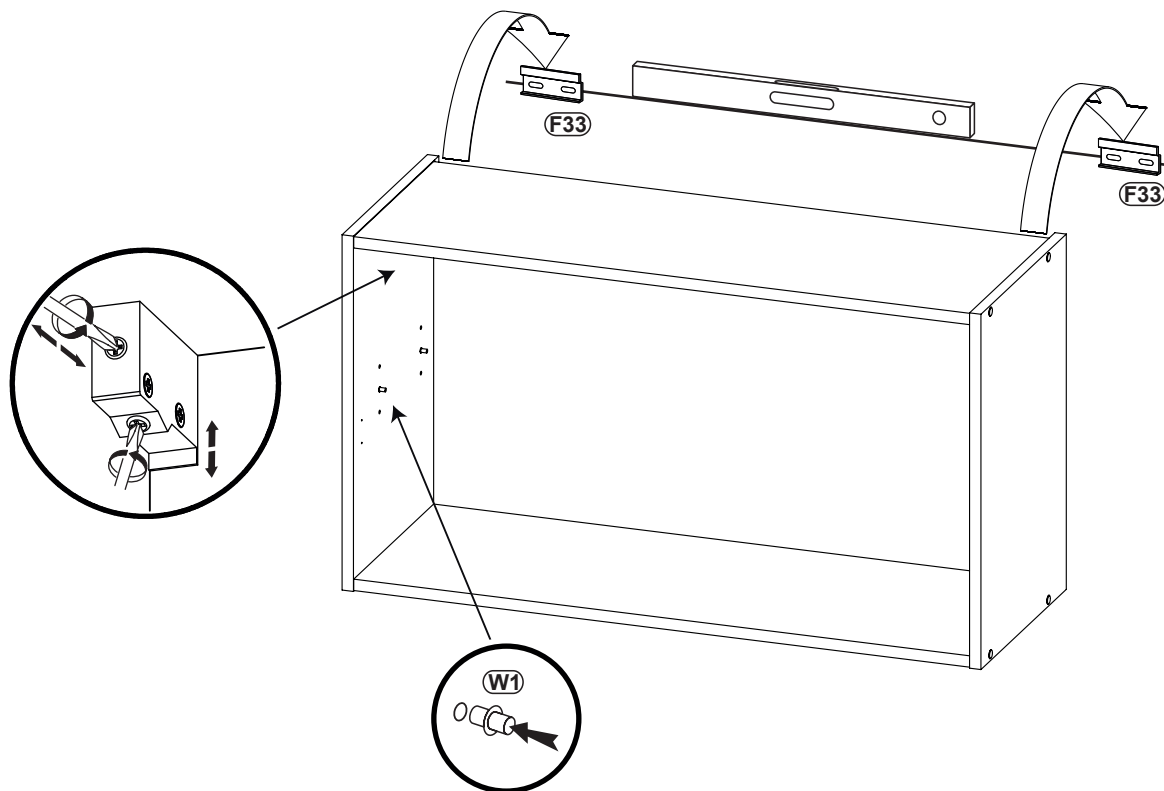
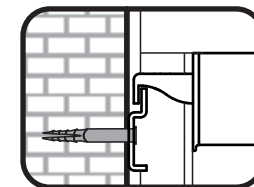
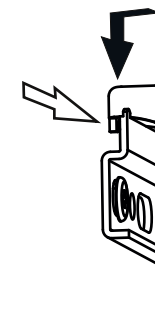
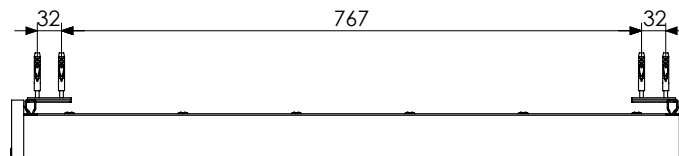
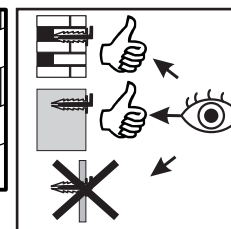
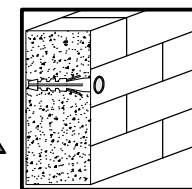
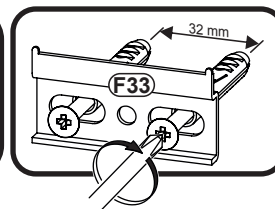
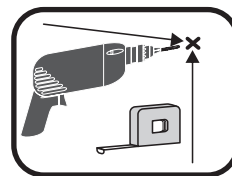
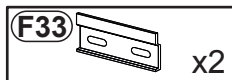
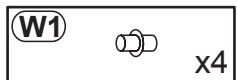

6

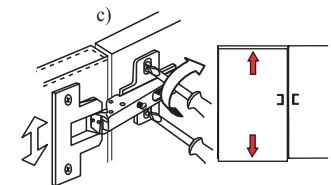
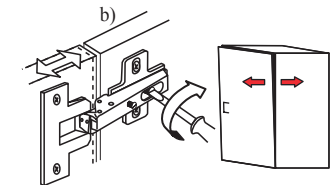
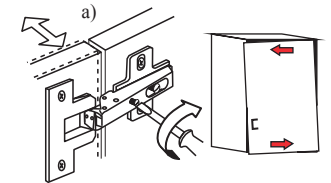
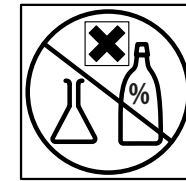
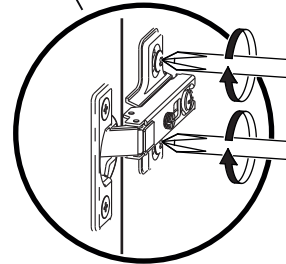
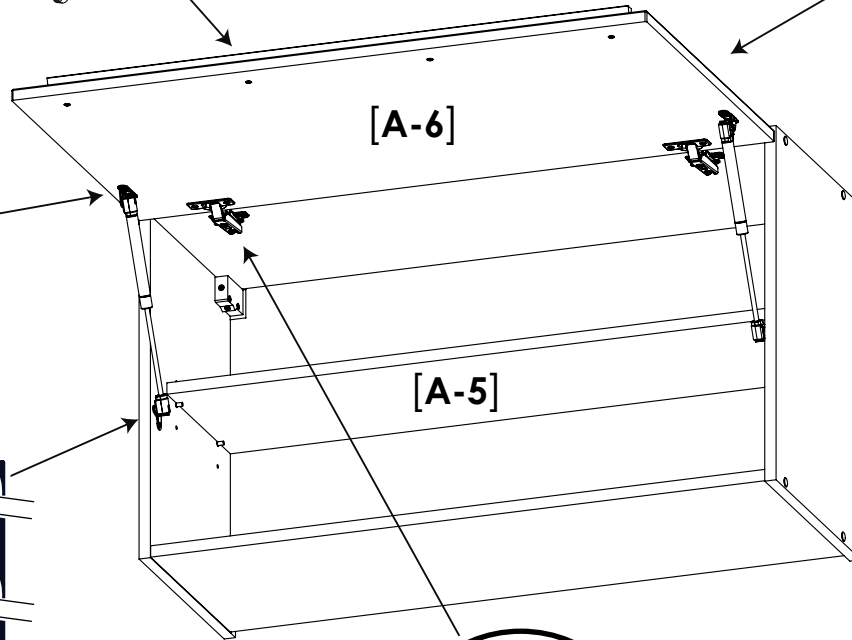
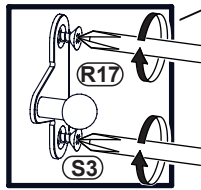
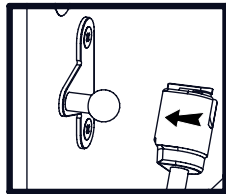
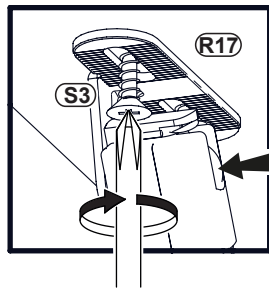
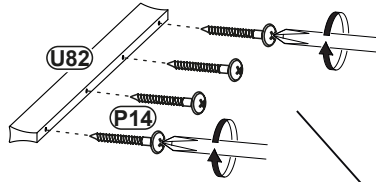
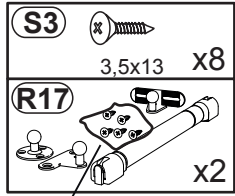

7



 **Colli 5/6**

L22		x8
S9		4x16 x16
S12		4x30 x8

