

HOMESTORY

WOHNEN, WIE ES DIR GEFÄLLT.

SPESIEN

AUFBAUANWEISUNG



BALTIMORE ESSTISCH MIT AUSZUGSFUNKTION

setone
by Musterring

(Bitte aufbewahren) (Stand 17.05.2024)

Nutzen Sie die Sicherheit einer großen Marke.



5 Jahre Garantie.

Auf set one Möbel ist Verlass.

Die Garantiebestimmungen, Gebrauchs- und Pflegeanweisungen sind im set one Möbel-Gütepass geregelt.



Service-Information

Sie erreichen uns per E-Mail oder über das Servicetelefon zu den üblichen Geschäftszeiten.



Individualität

Die set one Produktkennzeichnung belegt, dass Sie ein Unikat gekauft haben.



Pflege

Wir empfehlen Musterring Pflegeprodukte.

Lederpflege & Reinigung

Stoff-/ Mikrofaserpflege & Reinigung

Holzpflege und Sonderprodukte



Zu bestellen unter www.musterring-care.com
oder unter der kostenlosen Beratungsnummer
+ 49 (0) 800 / 88 88 885.

Bei Fragen sprechen Sie uns bitte an;
wir helfen Ihnen gerne weiter.

Zur Werterhaltung Ihrer Möbel

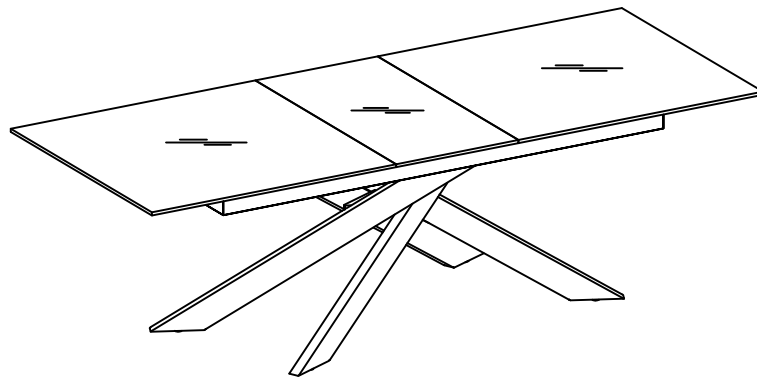
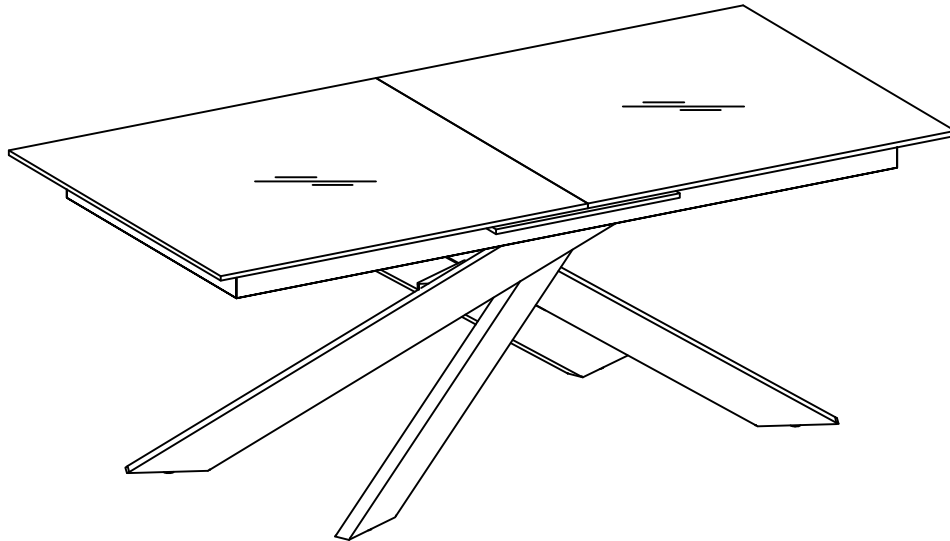

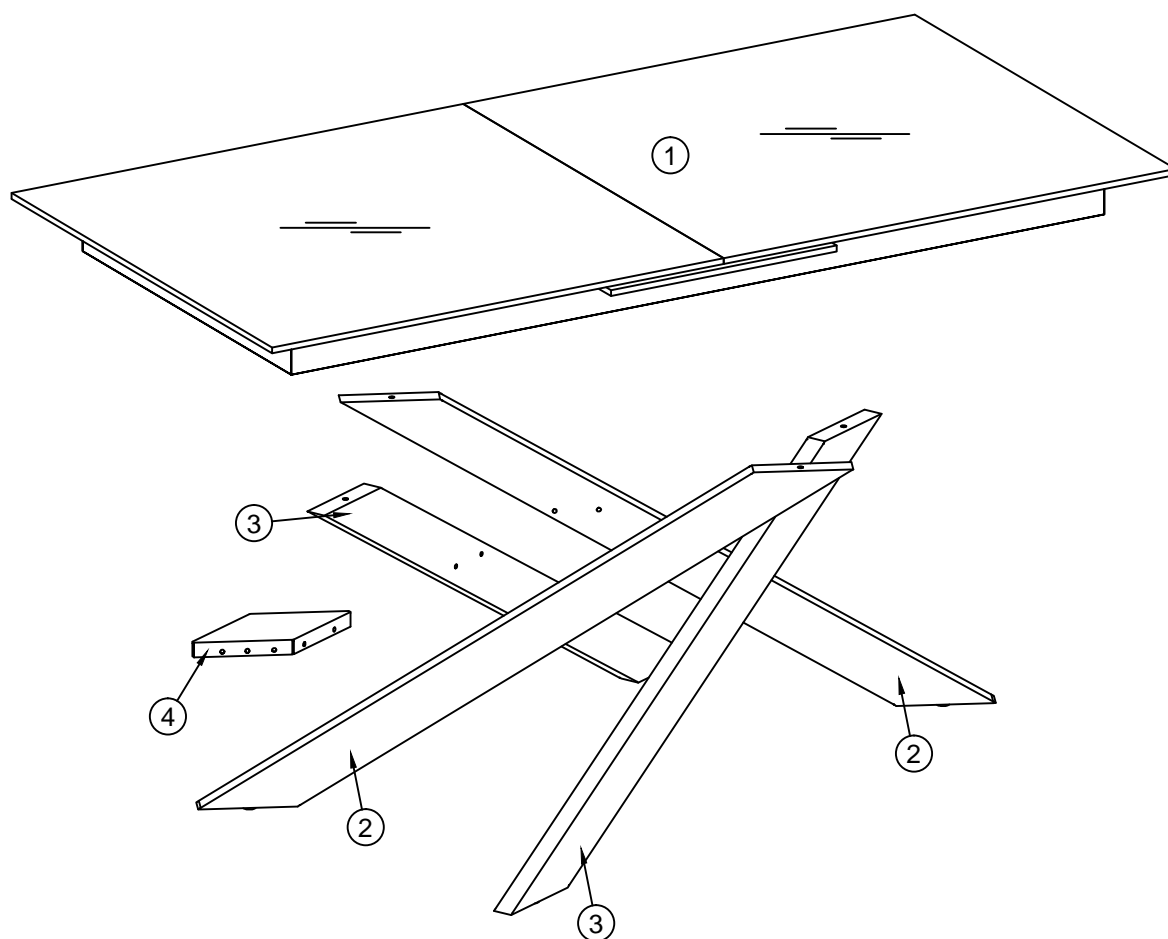

BALTIMORE

			✓
①	1	1000x2000x100	
②	2	1405x100x40	
③	2	1385x100x40	
④	1	356x168x30	

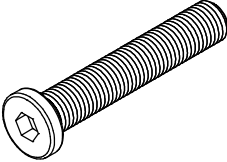
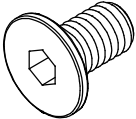

BALTIMORE

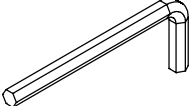
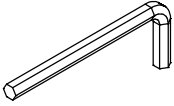
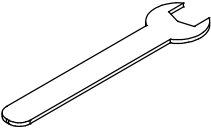
<p>A x 4</p>  <p>M8x50 mm</p>	<p>B x 8</p>  <p>M8x15 mm</p>	<p>C x 4</p>  <p>Ø30/M8</p>	<p>D x 1</p>  <p>5 mm</p>	<p>E x 1</p>  <p>4 mm</p>
<p>F x 2</p>  <p>14 mm</p>				

1

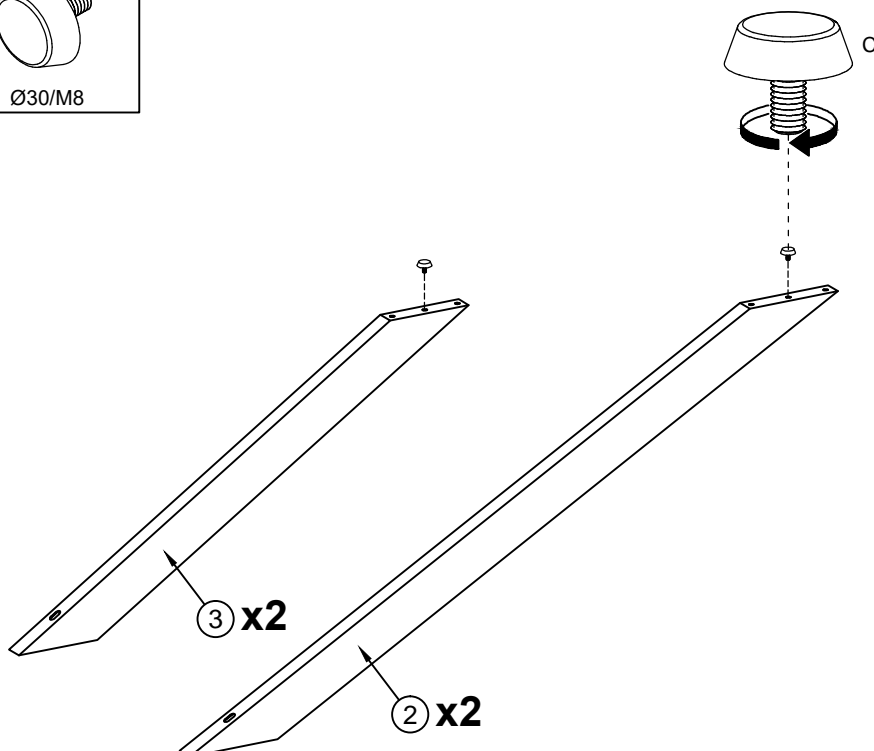
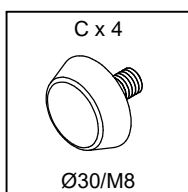

2

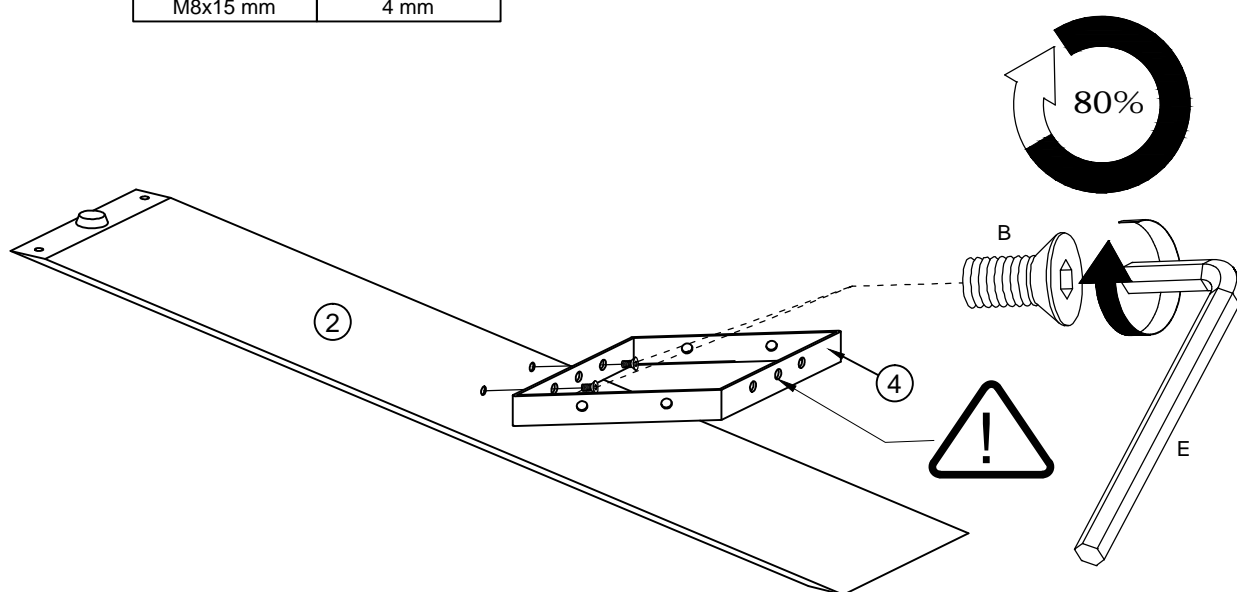
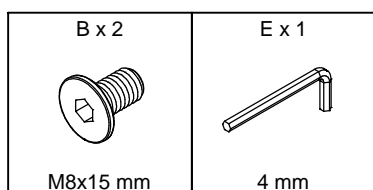

3

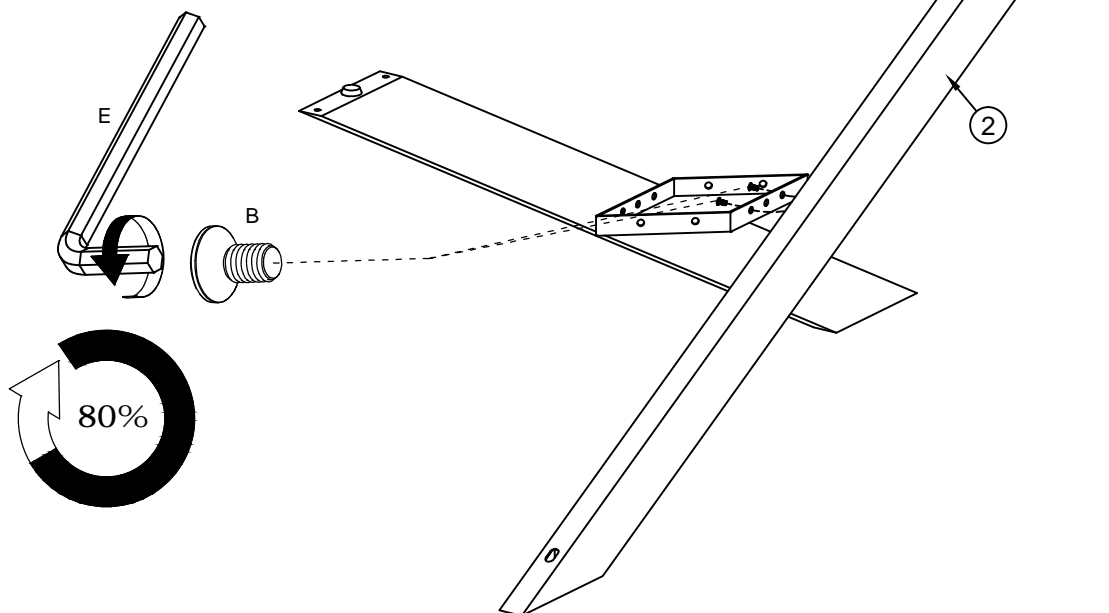
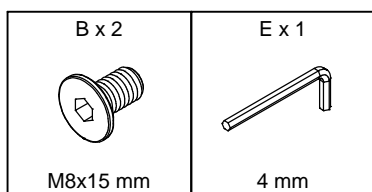

4

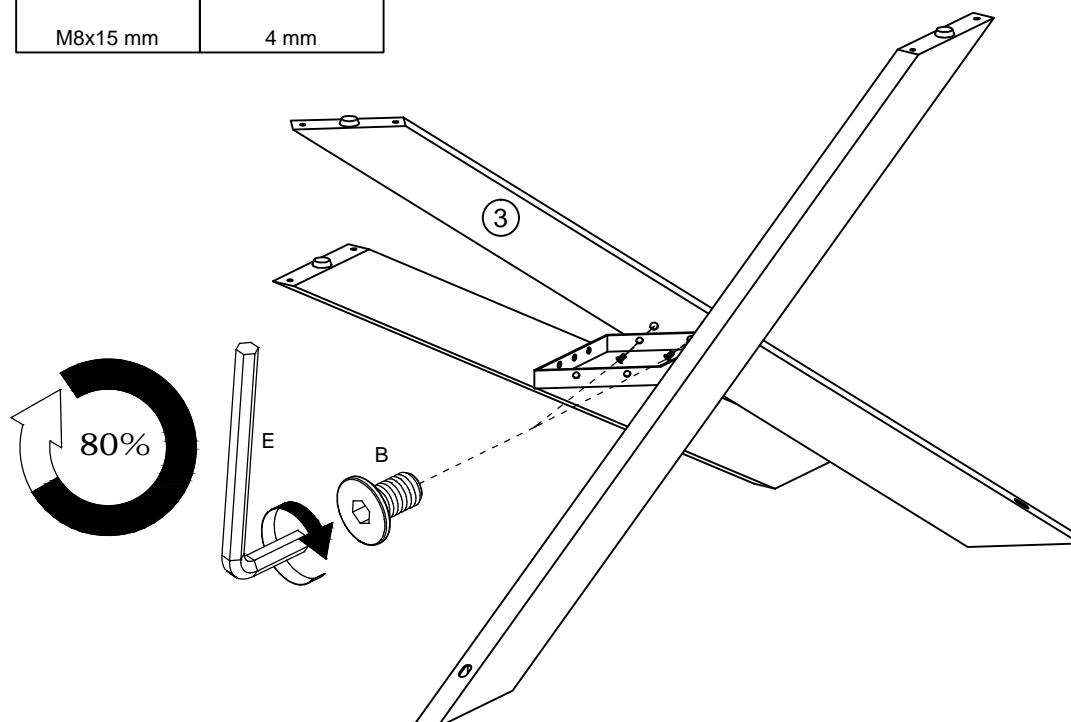
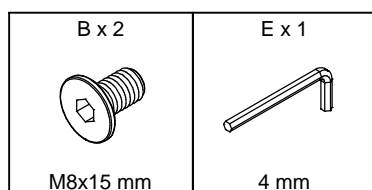

5

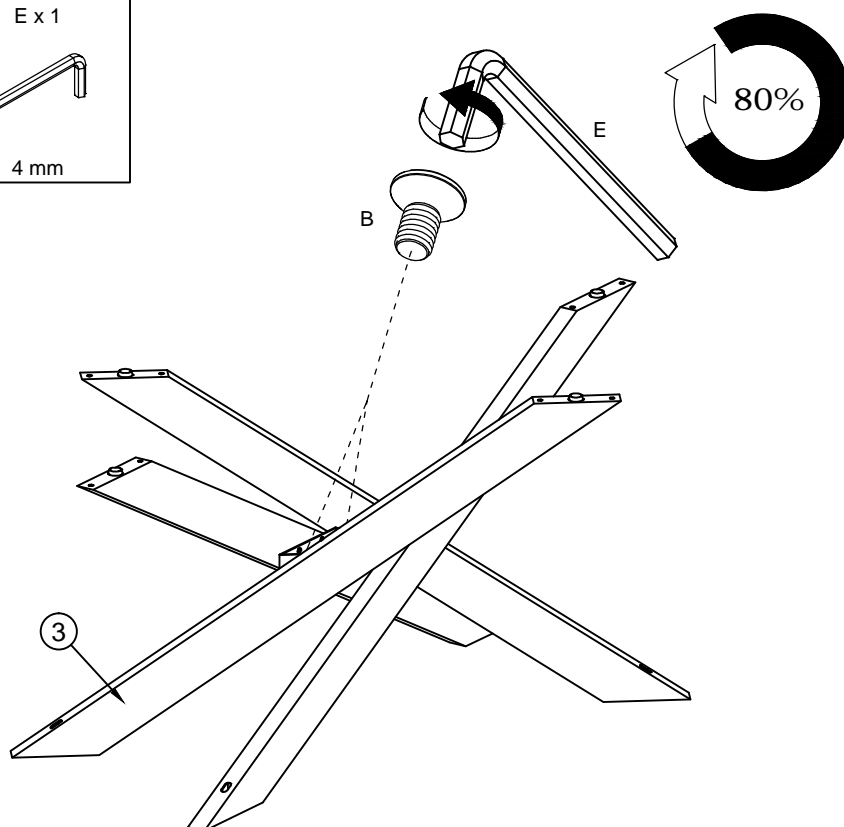
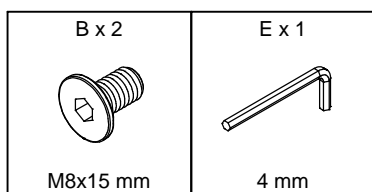

6

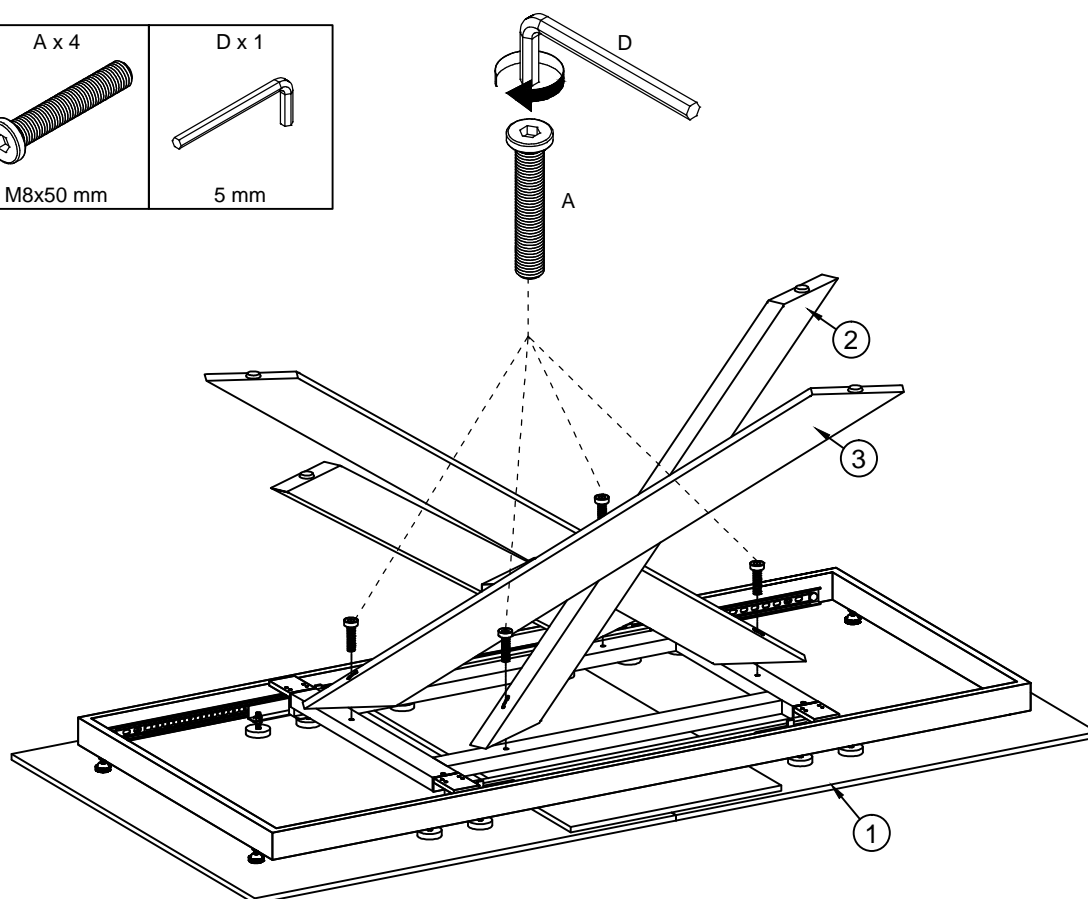
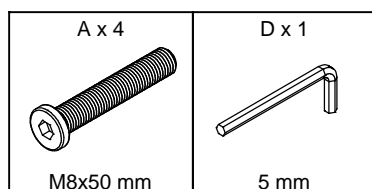

7

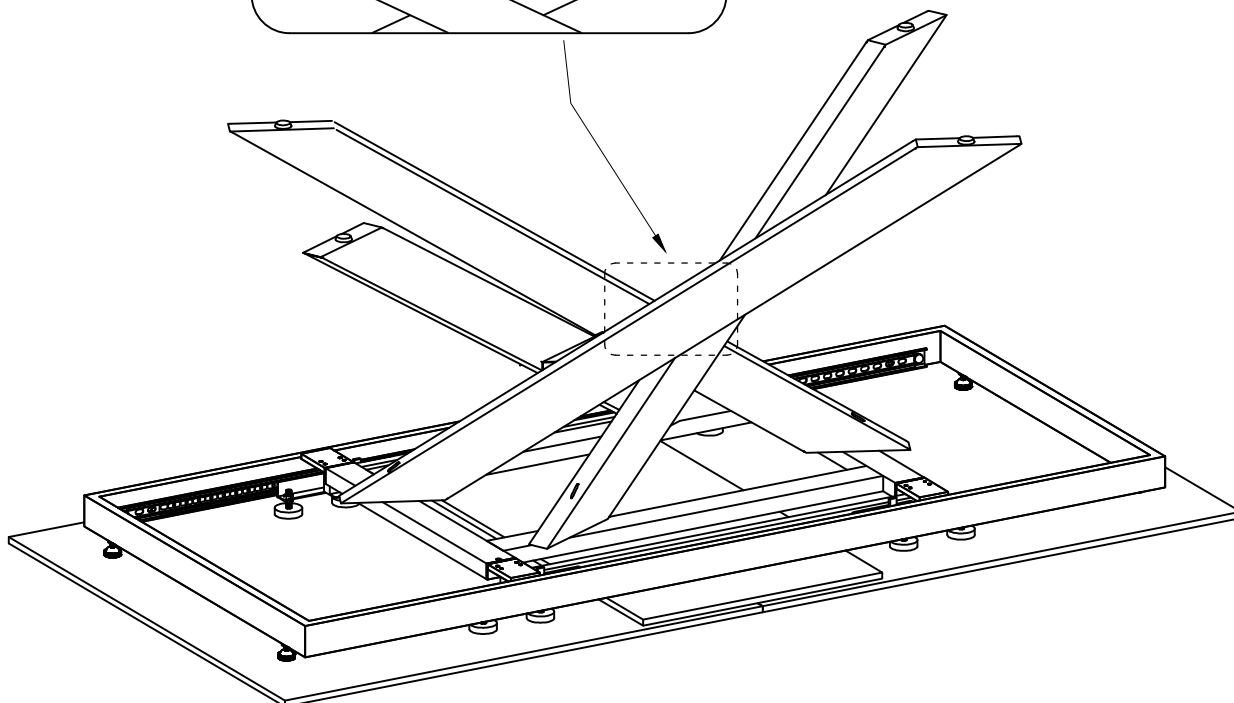
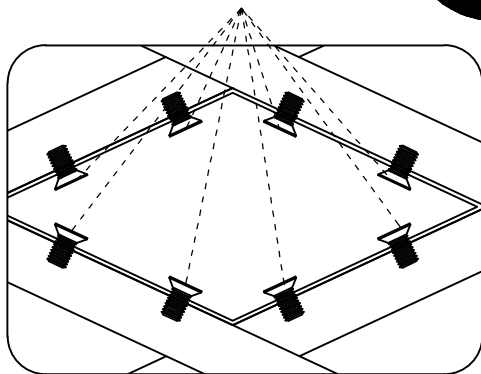
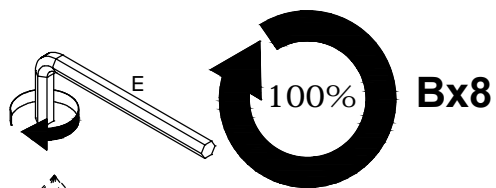
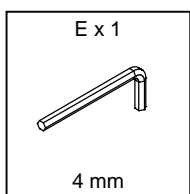

8

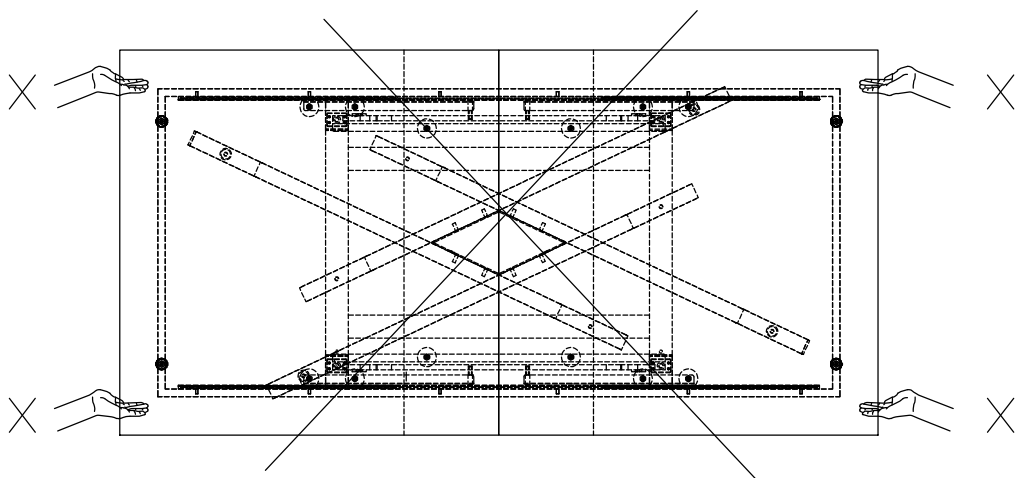
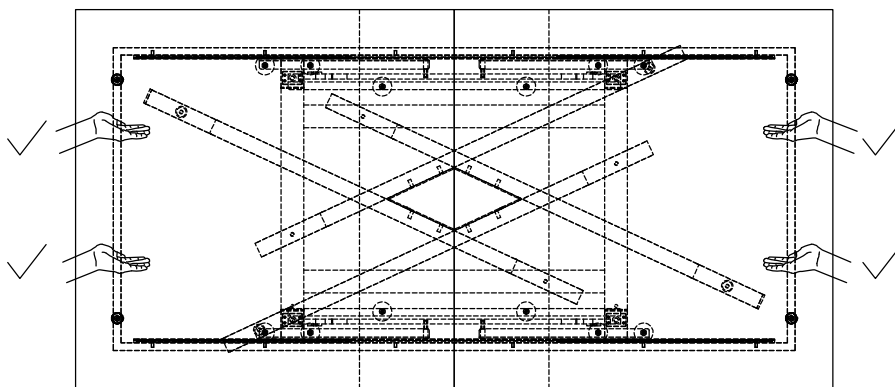
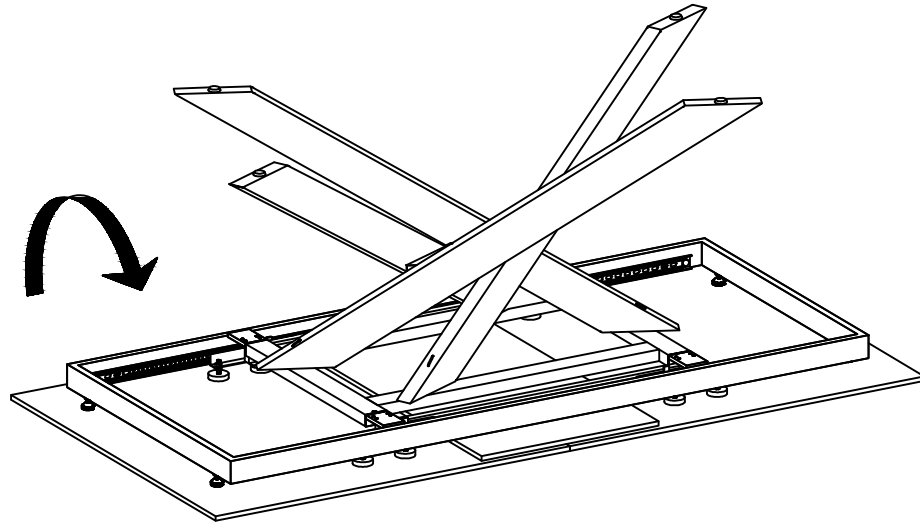

9

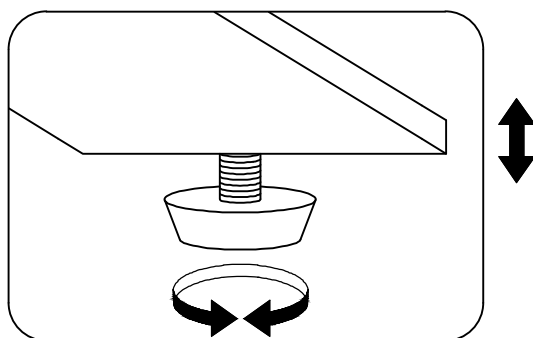
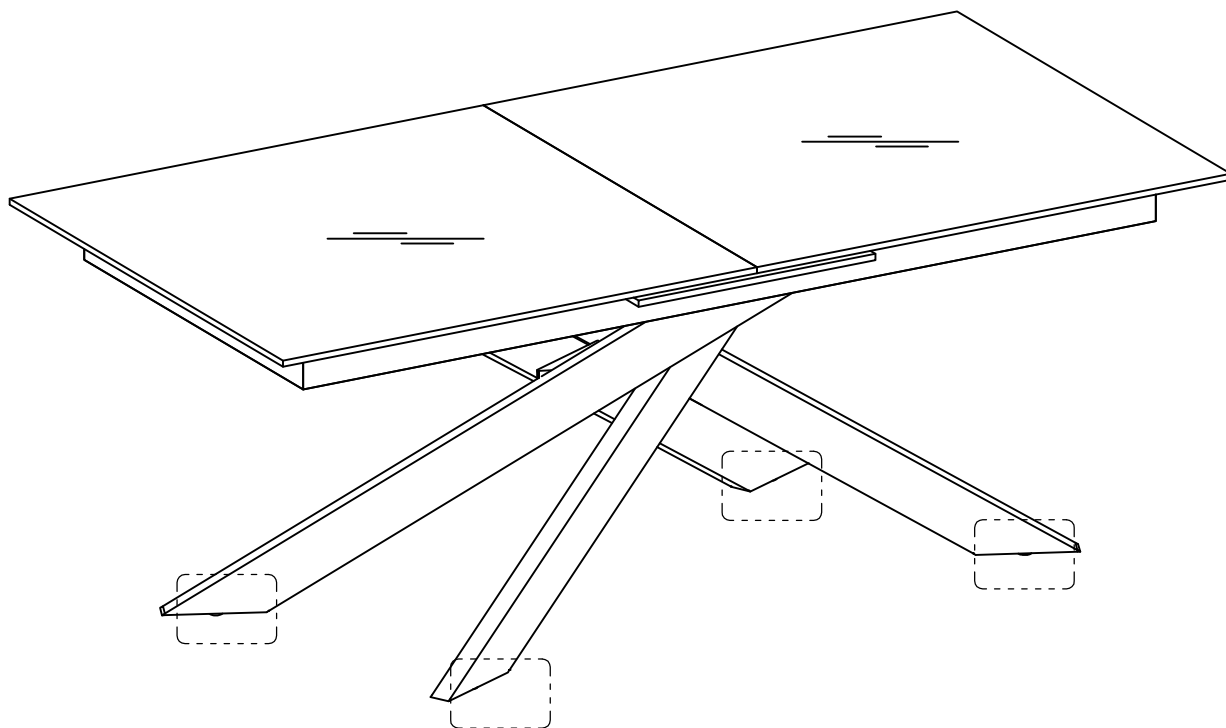

10

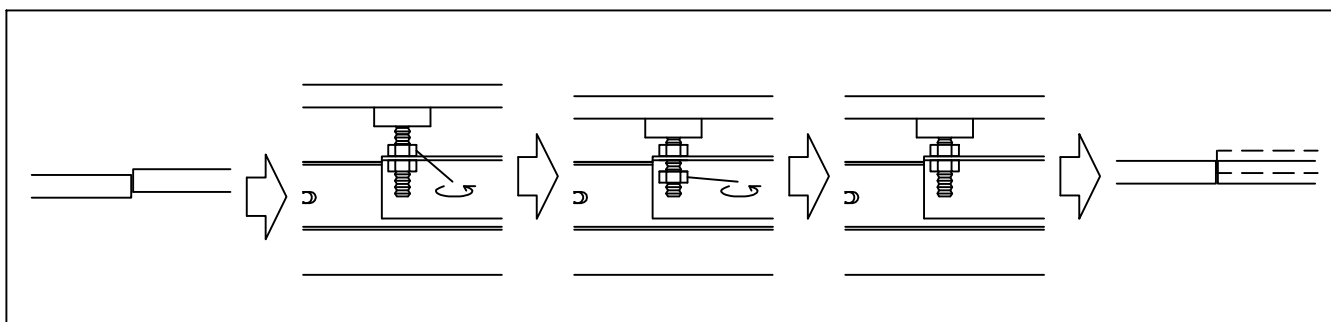
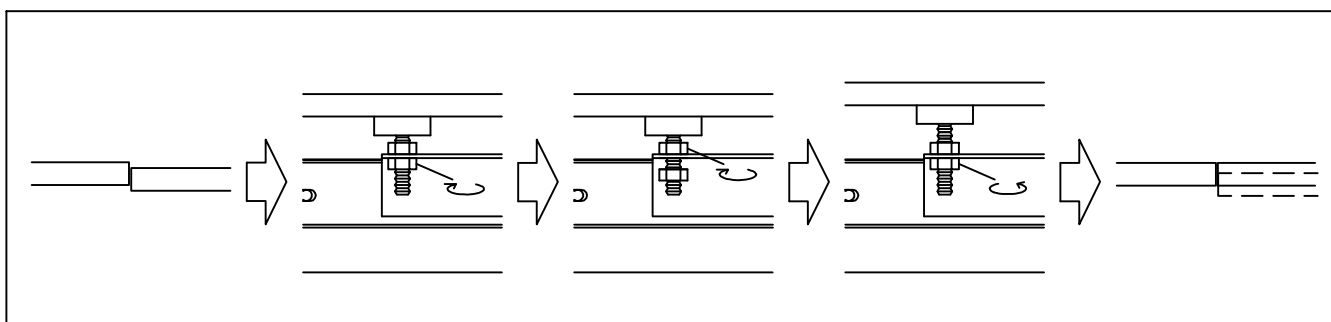
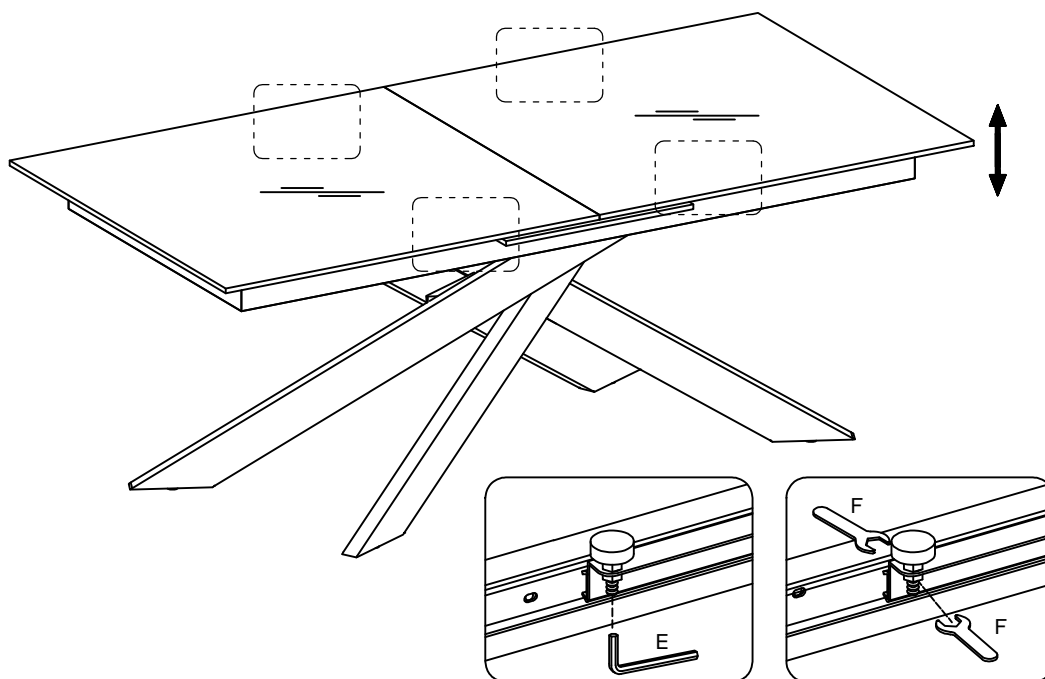
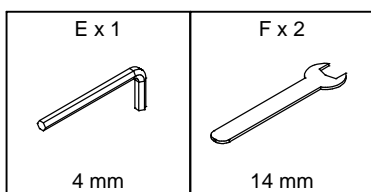

11

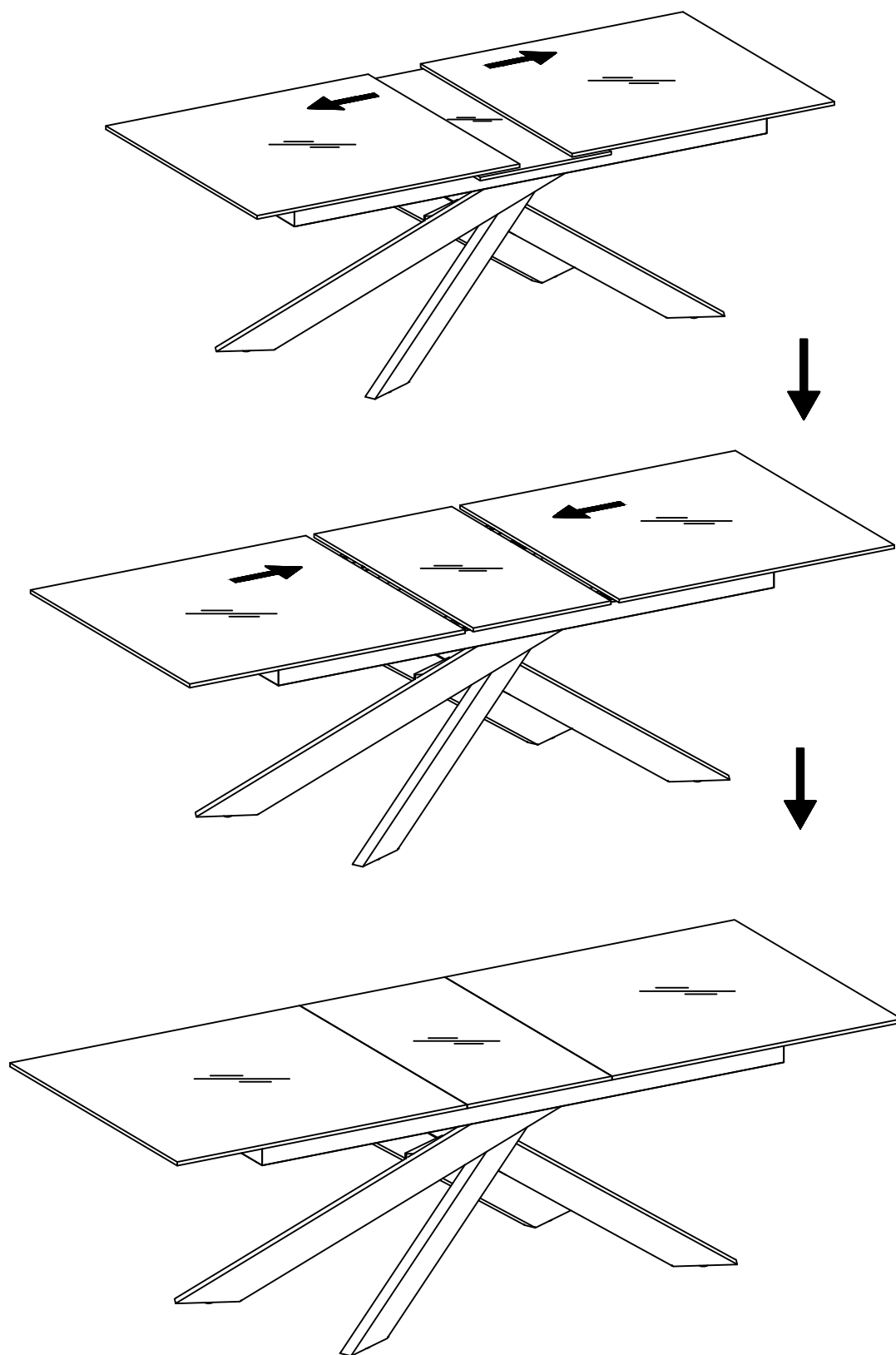

12

