

TIBOR-G

10 T3 RM 20

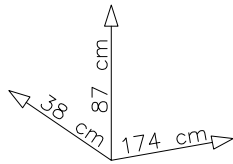

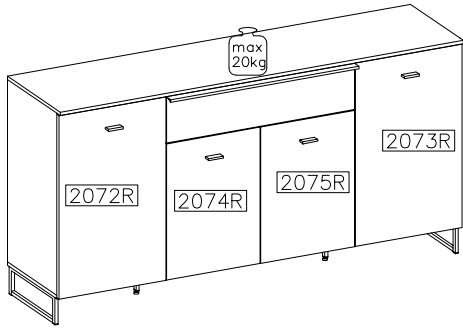

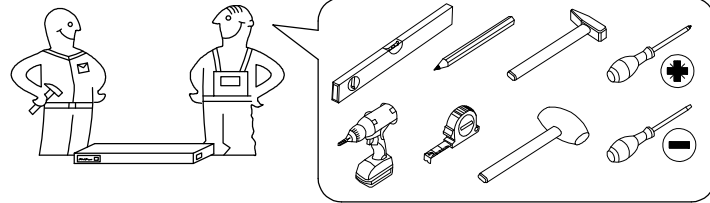
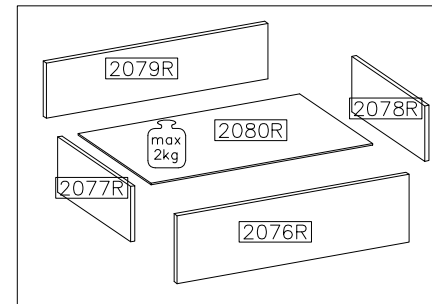
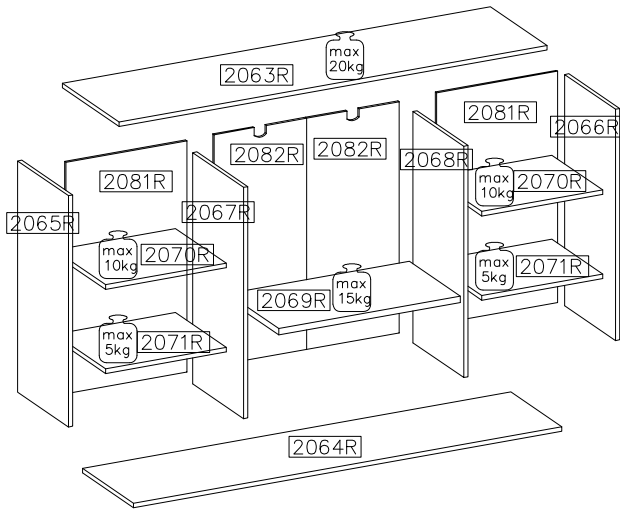
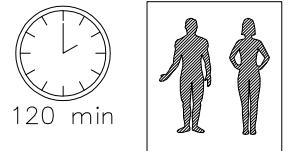
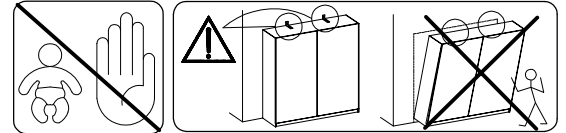
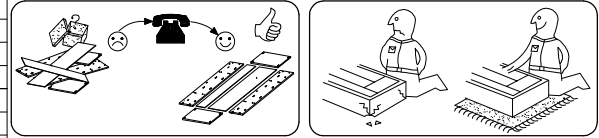
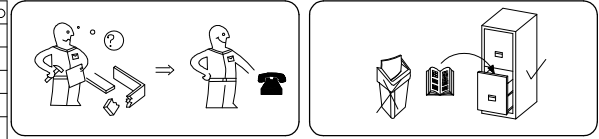

#	ART. NR	L	W	T	Q	Col.No
1	2063R	1736	380	16	1	2
2	2064R	1736	360	16	1	2
3	2065R	736	360	16	1	1
4	2066R	736	360	16	1	1
5	2067R	736	340	16	1	1
6	2068R	736	340	16	1	1
7	2069R	851	340	22	1	1
8	2070R	408	340	16	2	3
9	2071R	408	340	16	2	3
10	2072R	748	431	16	1	3
11	2073R	748	431	16	1	3
12	2074R	543	431	16	1	3
13	2075R	543	431	16	1	3
14	2076R	200	865	16	1	2
15	2077R	300	140	16	1	2
16	2078R	300	140	16	1	2
17	2079R	812	123	16	1	2
18	2080R	826	308	2,5	1	1
19	2081R	423	750	2,5	2	3
20	2082R	423	750	2,5	2	3



A 32	B 12	C 22	D1 22	E 22	G6 4	G8 4	L-300 1 SET	PR1 14	F8 2	P12 8	P39 2
J4 8	L 12	P1 28	P7 2	P9 20	R2 8	F5 2	P21 8	V3 1	N4 1	P4 2	
S1 4	O 1	U4 2	N 2	V1 1	V2 1	V4 1	V7 1				



1

$\varnothing 8 \times 30 \text{mm}$		A
	8	
$\varnothing 15 / 12 \text{mm}$		C
	4	
		J4
	4	

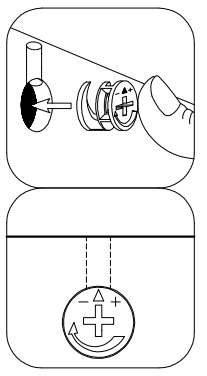
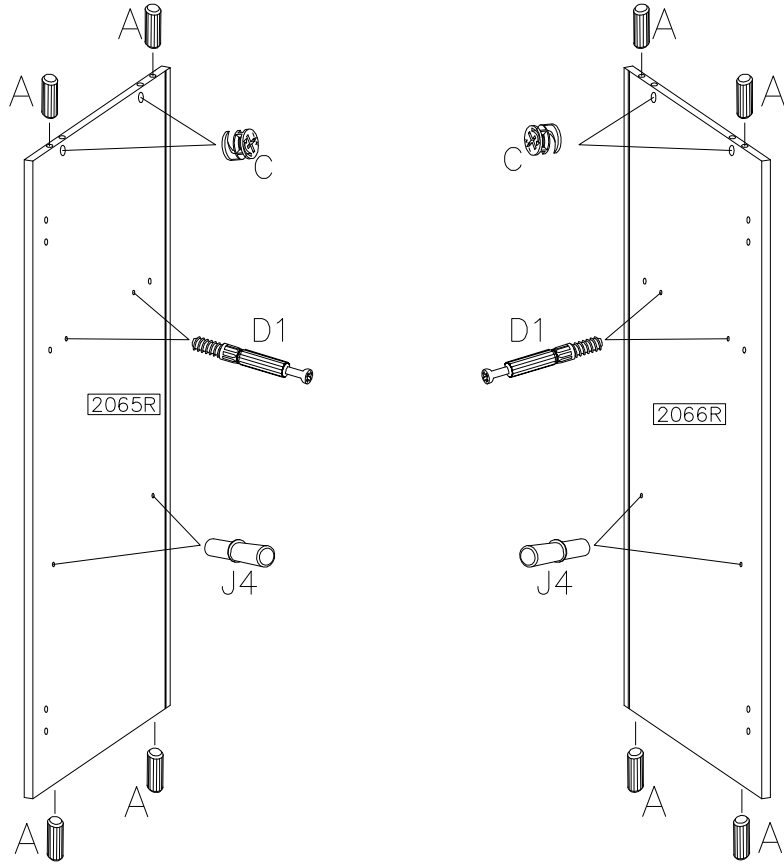
	D1
4	



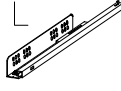
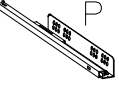

2

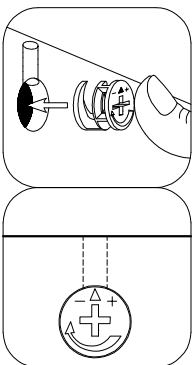
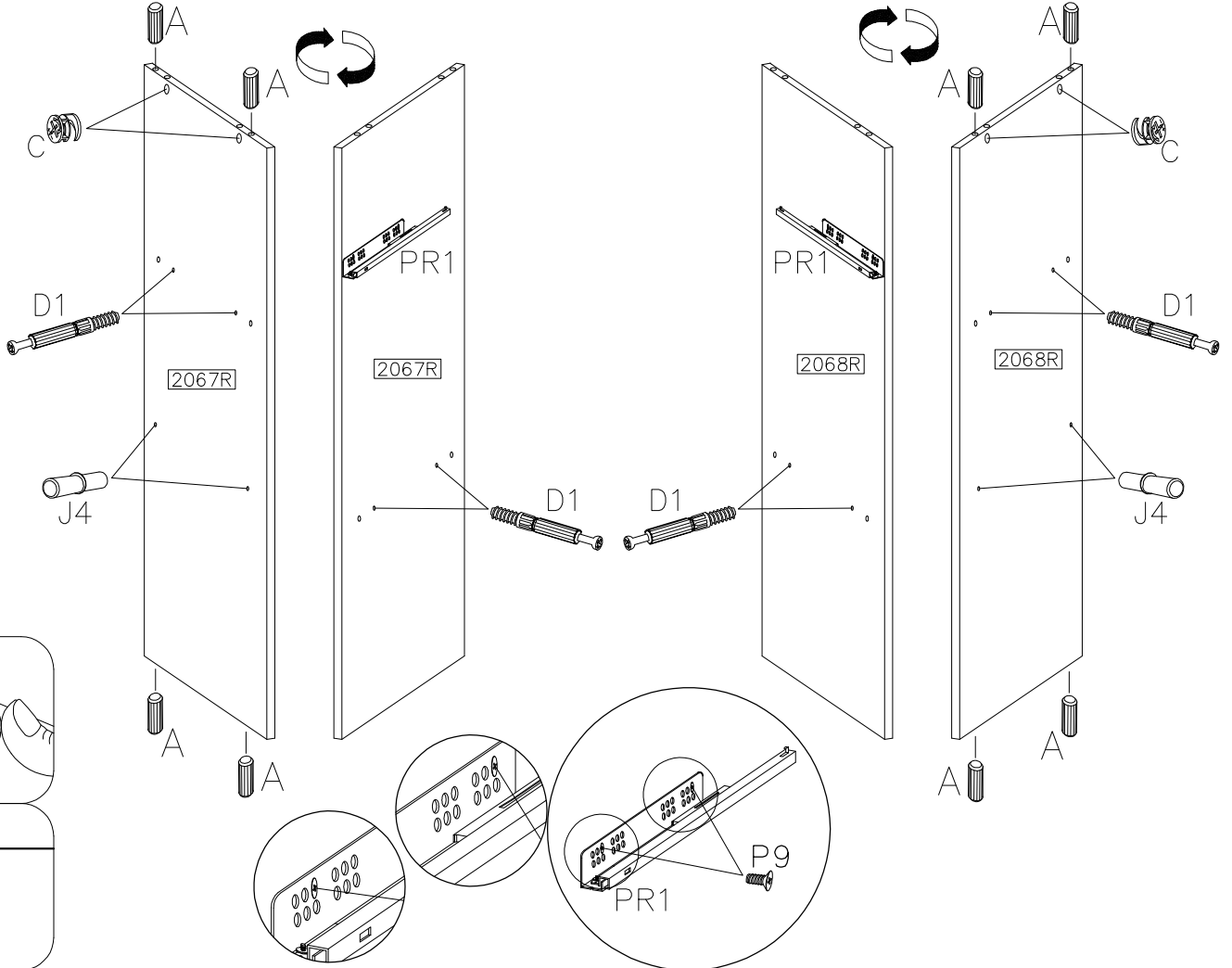
$\varnothing 8 \times 30 \text{mm}$	$\varnothing 15 / 12 \text{mm}$				$\varnothing 5.0 \times 13 \text{mm}$	
A	C	J4	L-300	P	P9	D1
8	4	4	1SET		4	8



3

∅8x30mm	∅15/12mm
	
A	C
12	12

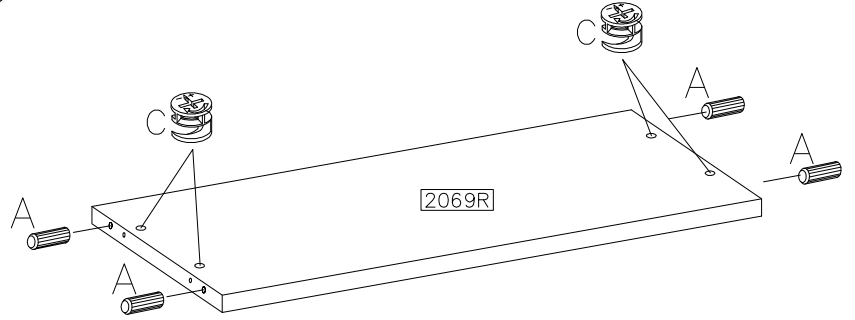
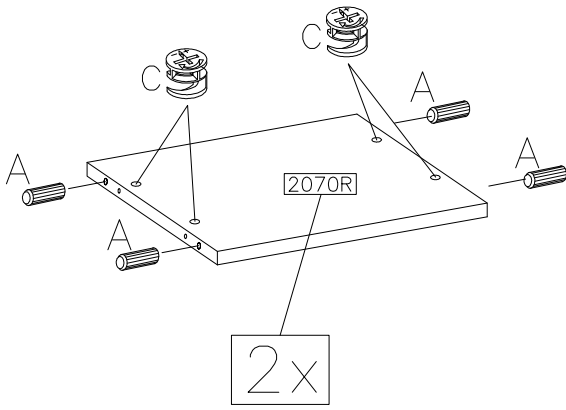
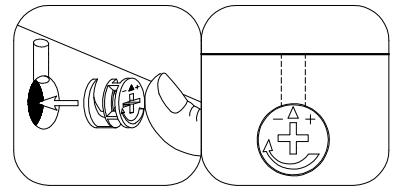

4

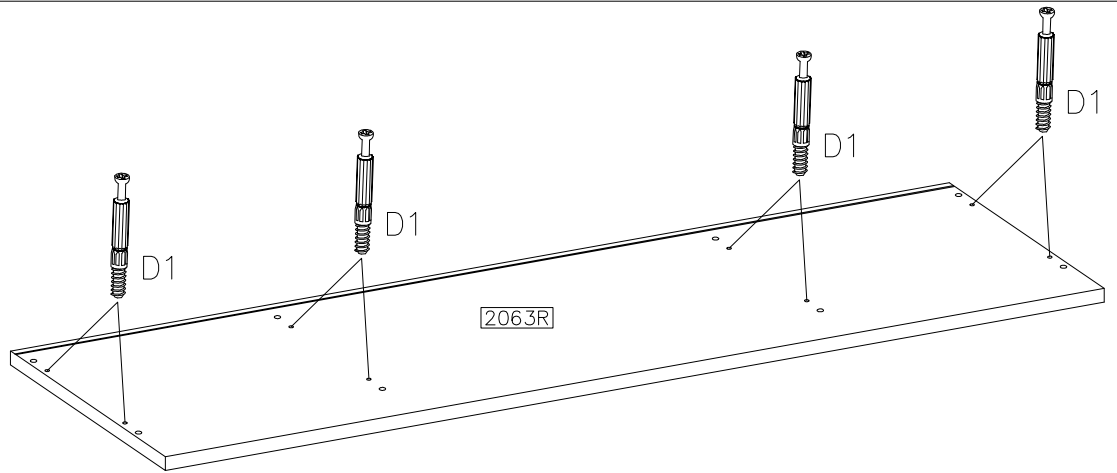
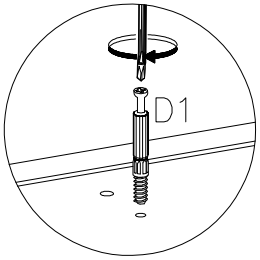
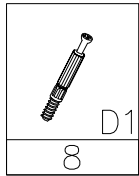

5

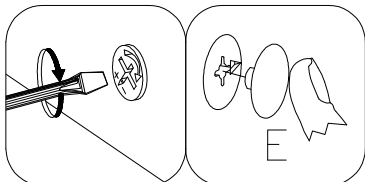
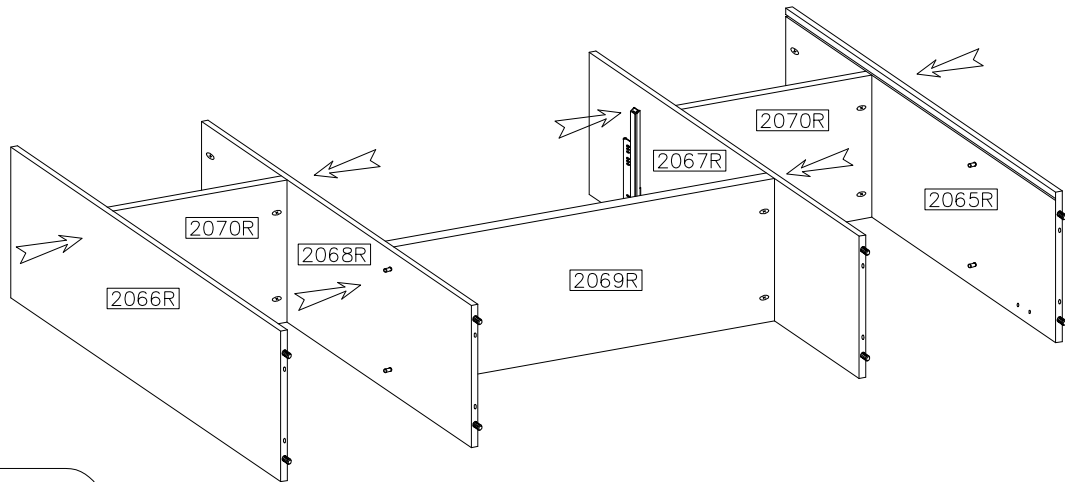
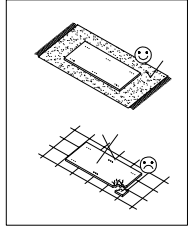
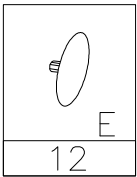

6

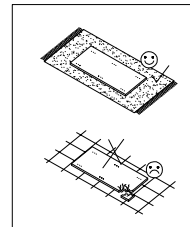
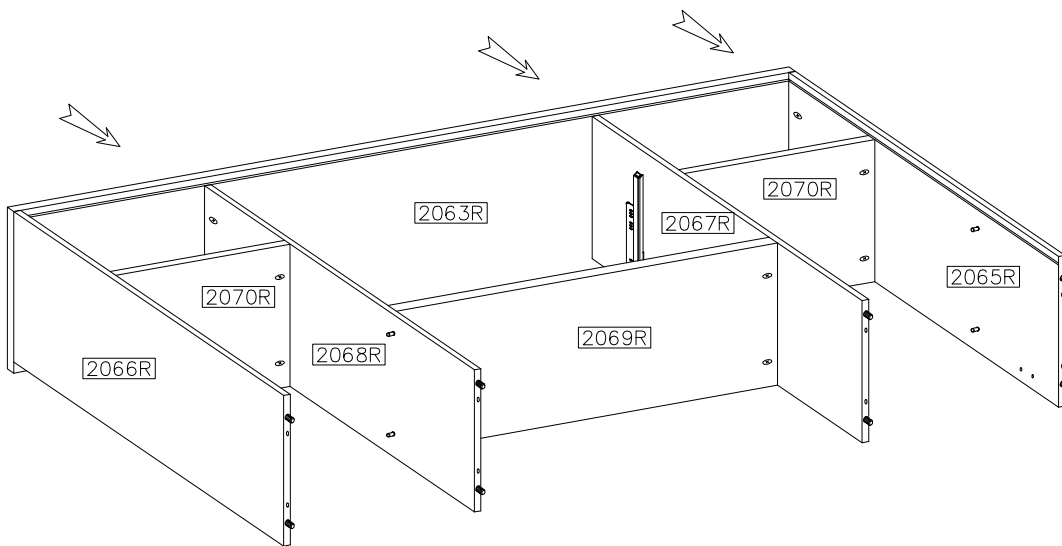
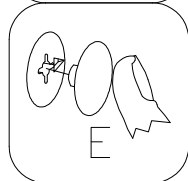
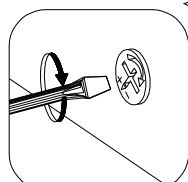
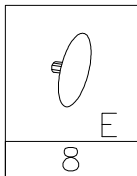

7

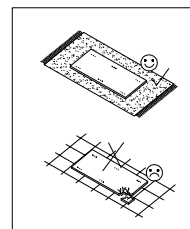
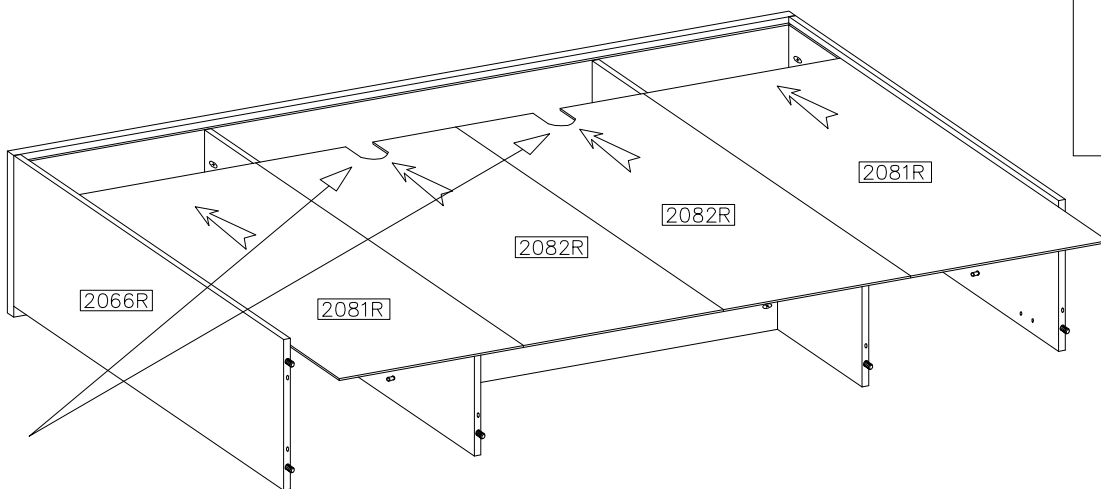

8

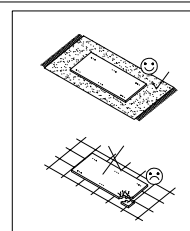
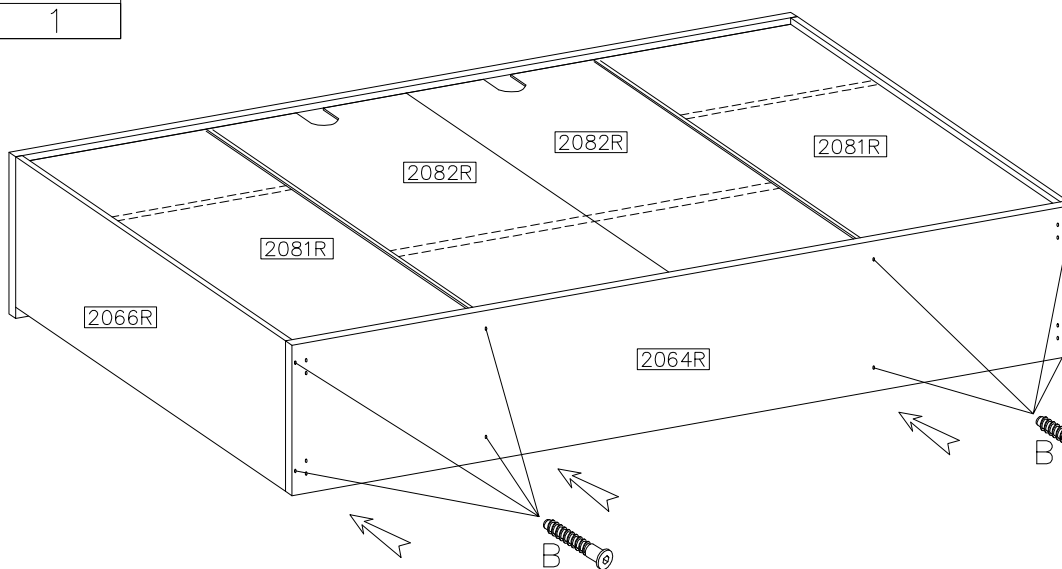
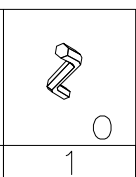
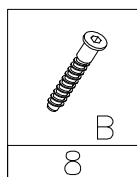

9

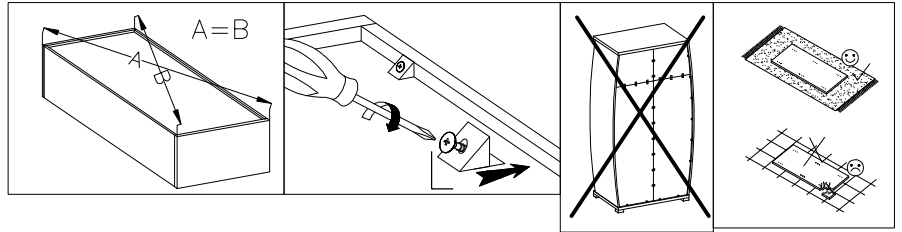

∅6,3x16mm



P39

8



L

12

∅3.0x16mm



P1

22



F8

14

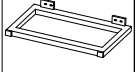

F6

2

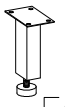

F5

2

4.0x16mm



P21

8

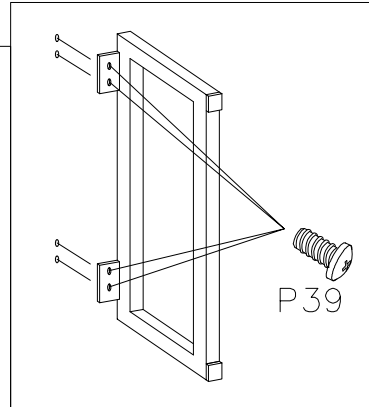
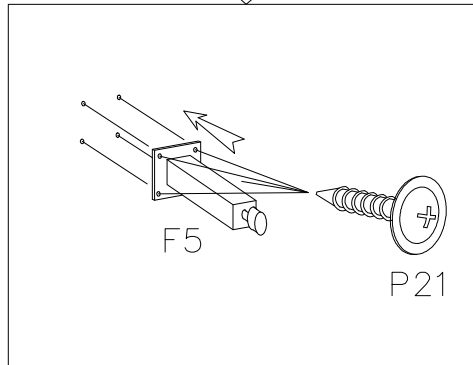
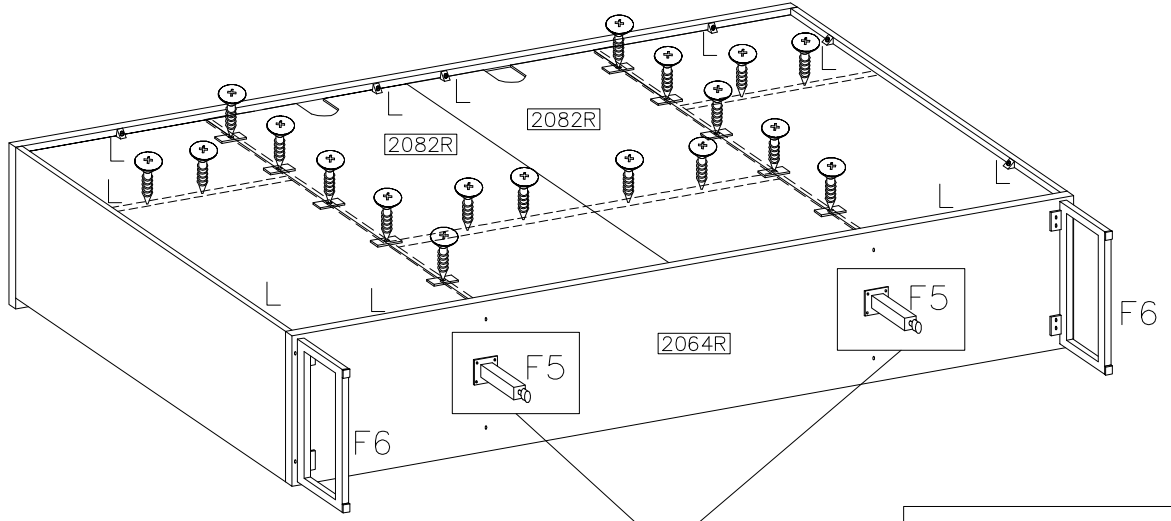

10

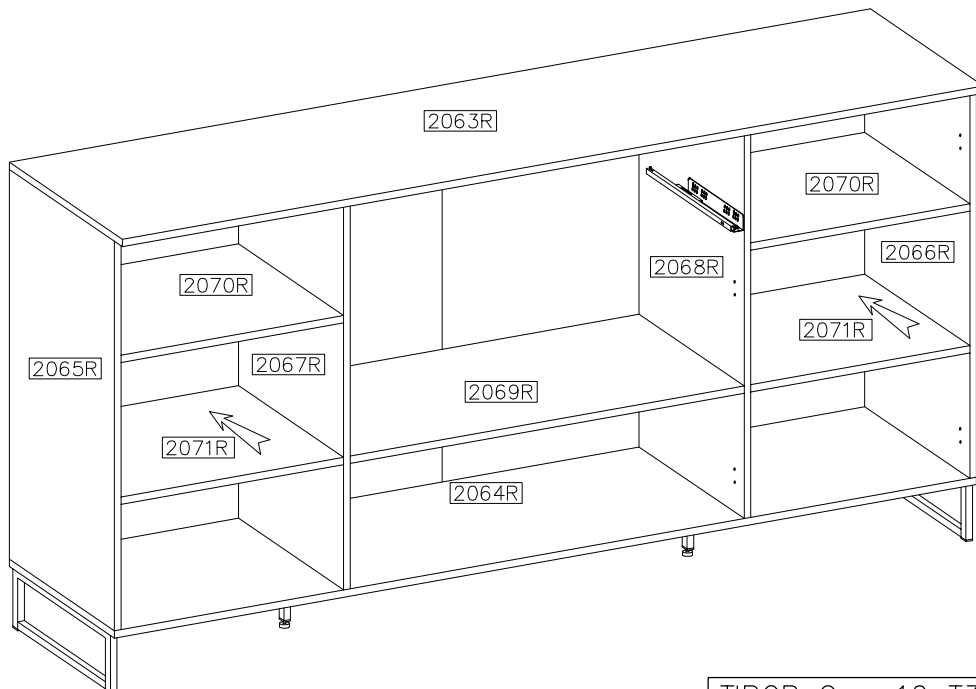
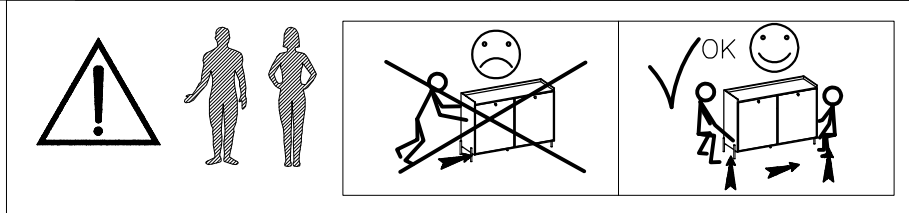

11

5.0x13mm



P9

16

M4.0x22mm



R2



S1

4

8

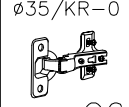

G6

4

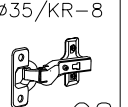

G8

4

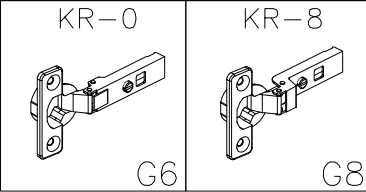

KR-0

G6

KR-8

G8

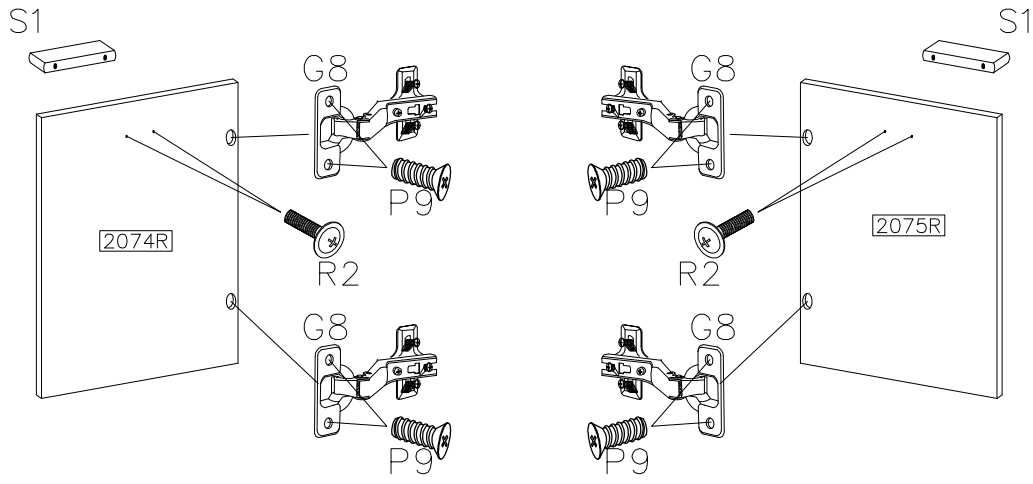
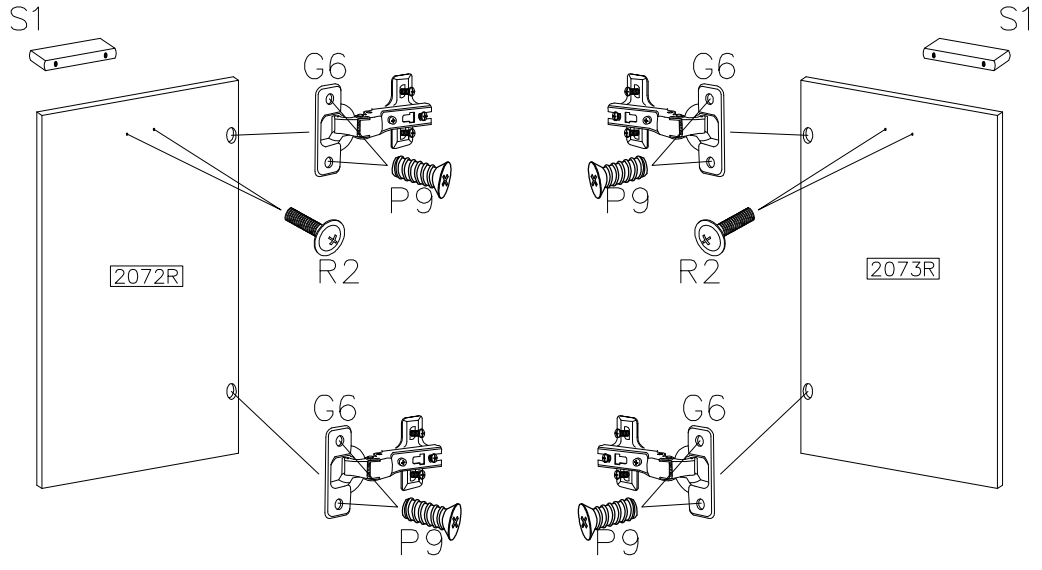

12

ø8x30mm



A

4

ø15/12mm



C

2



D1

2

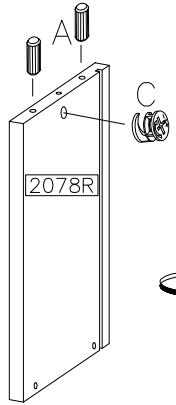

2078R

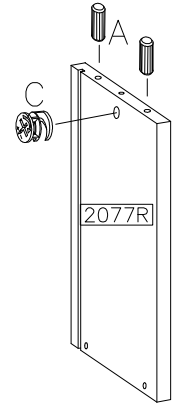

2077R

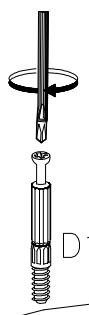

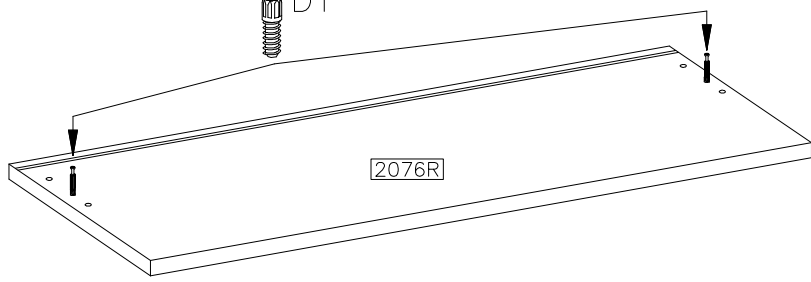

D1



2076R

13

	
B	O
4	1

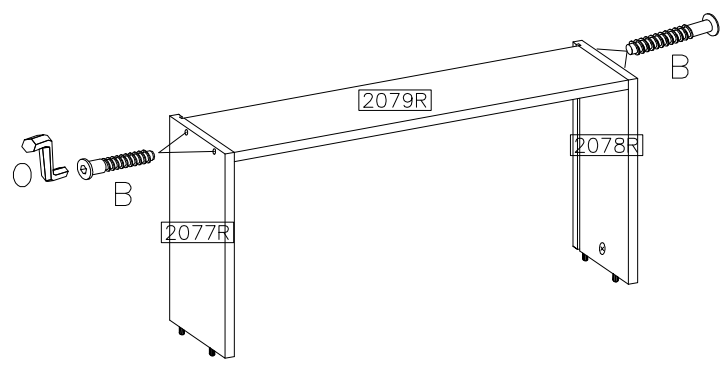

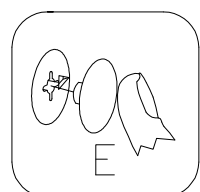
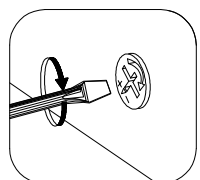
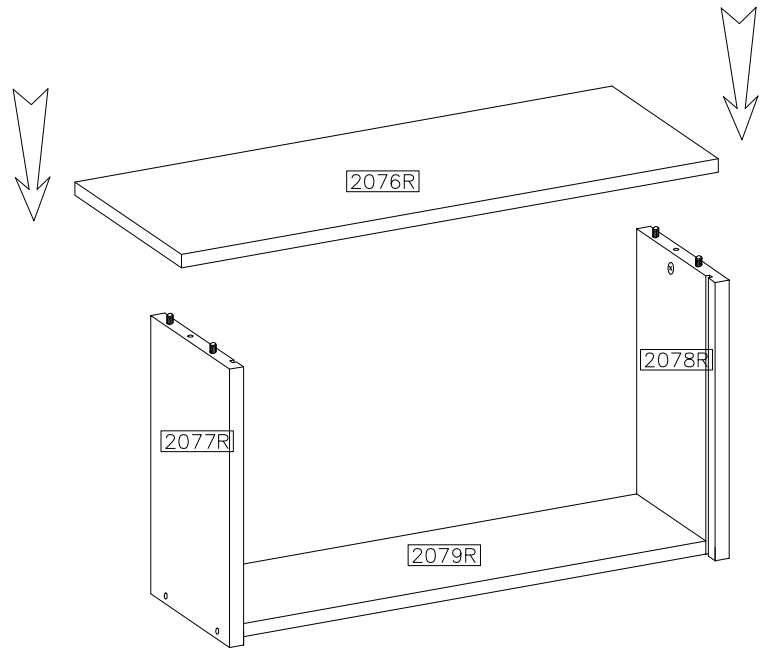

14

E
8



15

		
P1	N4	P4
6	1	2

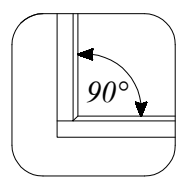
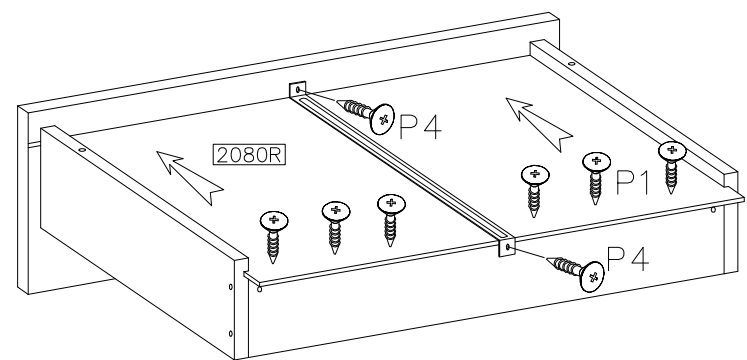

16

KA 260124
Lisa-GTP20

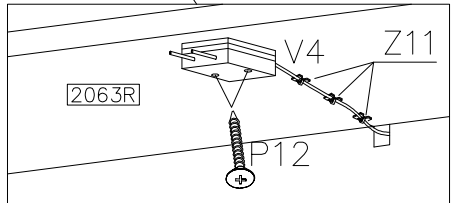
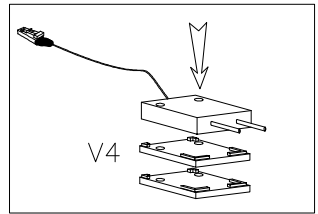
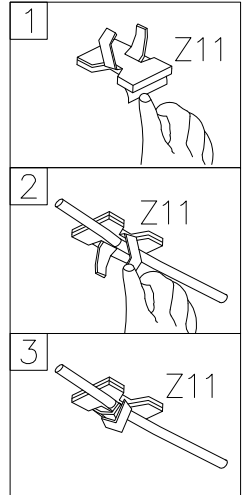
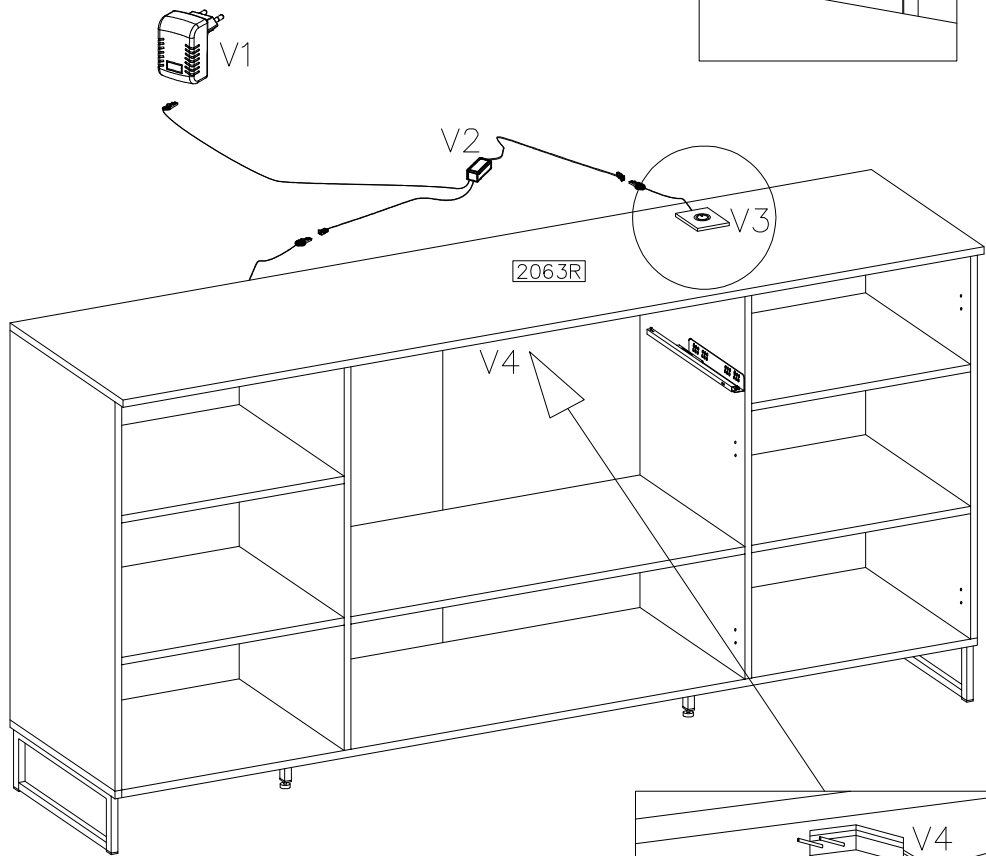
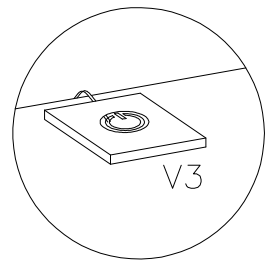
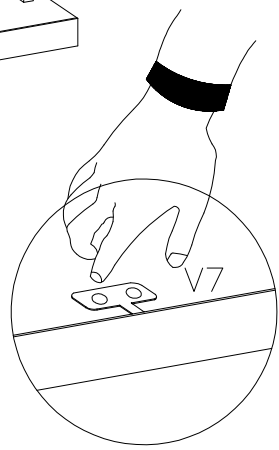
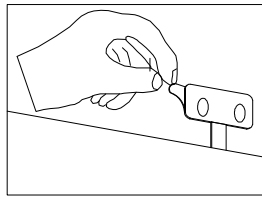
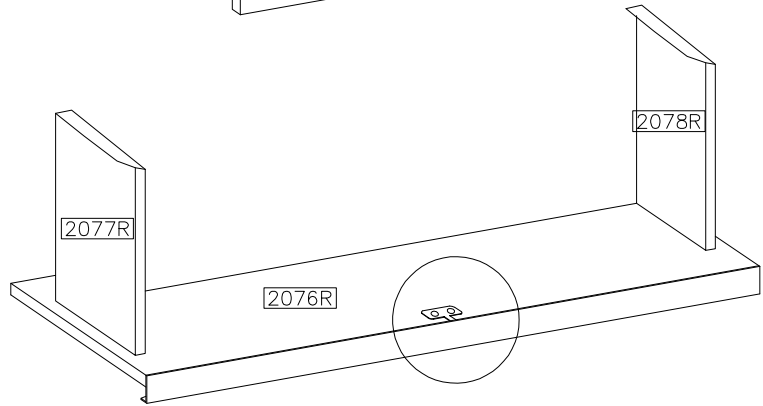
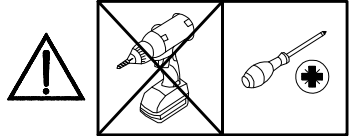
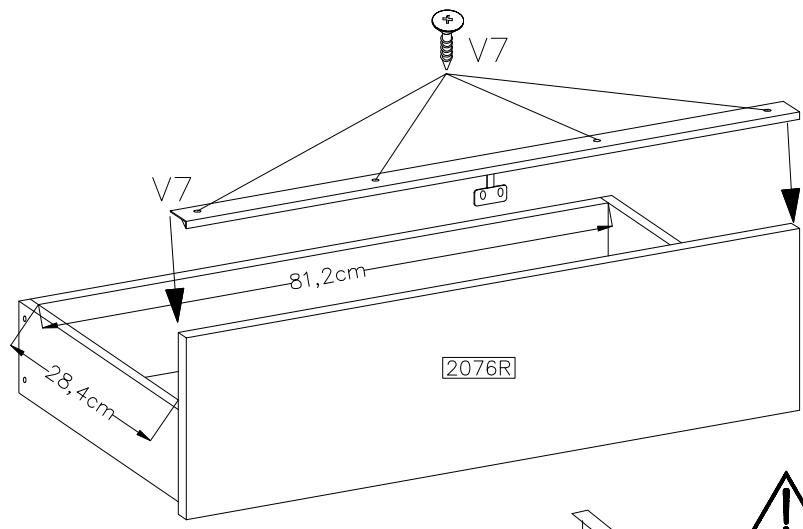
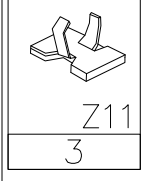
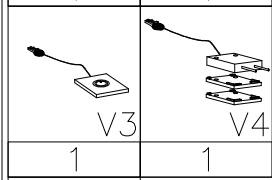
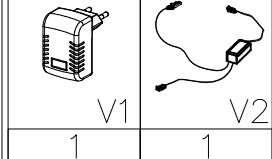
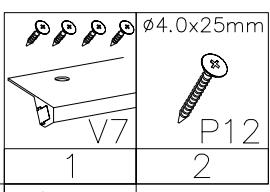

17

Ø3.0x20mm
P7
2

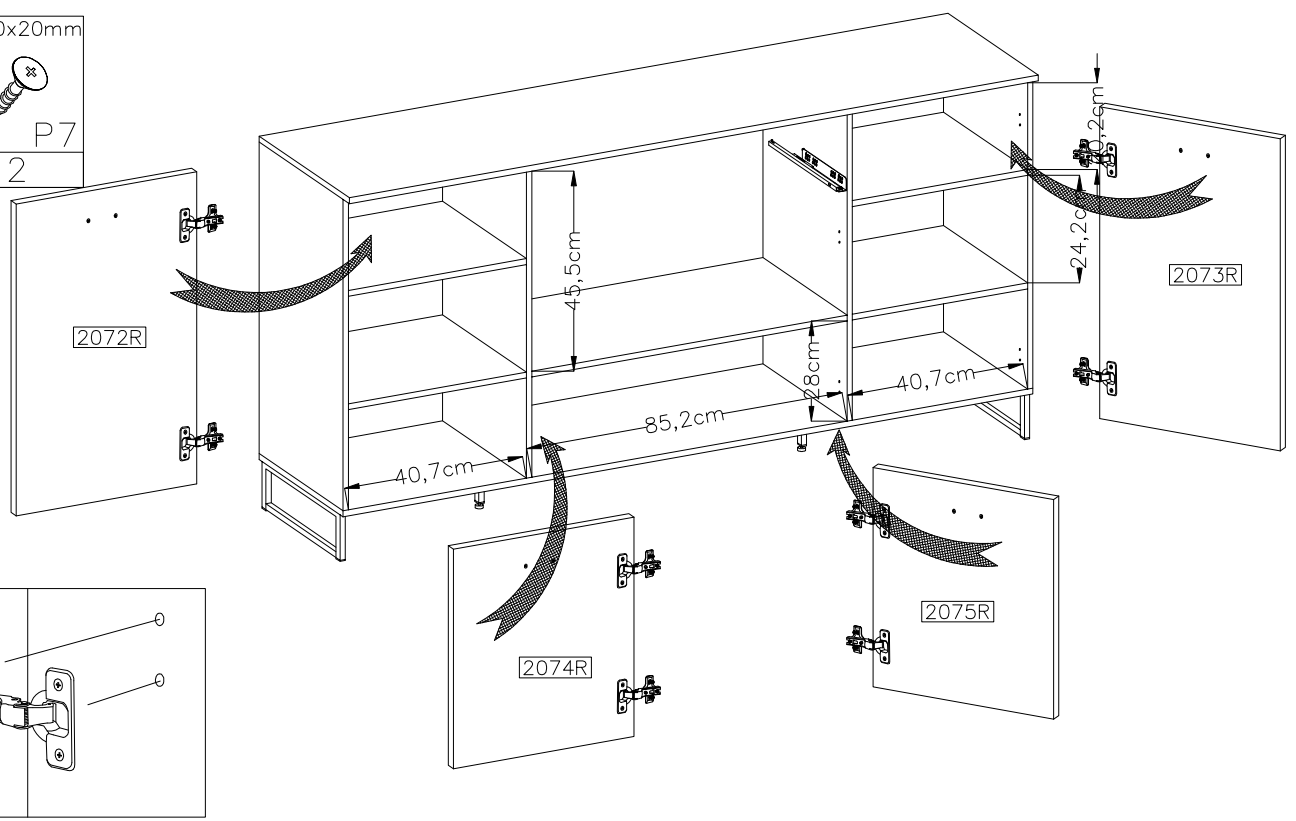

18

Ø8.0x50mm
U4
2

