

**MONTAGE**  
**ANLEITUNG**  
**ASSEMBLY INSTRUCTIONS**  
**MANUEL DE MONTAGE**

**LM: 29000 33**

# Inhaltsverzeichnis / Table of Contents / Contenu

## Auspacken, Unpacking, Déballage

Modellart / model type / Type de modèle

Seite / Side / Page

4

## Montagematerial, Assembly material, Matériel de montage

Modellart / model type / Type de modèle

Seite / Side / Page

5

## Stützfuß-Kufe montieren / Assembly of support feet and support runners / Montage du pied de support et du patin de support

Modellart / model type / Type de modèle

Seite / Side / Page

6 - 9

## Montage, Assembly, Montage

Modellart / model type / Type de modèle

Seite / Side / Page

108, 135/136, 173, 174, 591,

10 - 11

507/508

12 - 14

543/44, 545/46, 547/48, 553/54, 555/56, 557/58,

15 - 17

571/72, 573/74, 575/76, 577/78, 581/82, 583/84, 585/86, 587/88,

15 - 17

543, 544, 545, 546, 547, 548,

18

231, 232, 233, 234, 235, 236, 237, 238, 272, 274, 276, 278,

19

237, 238, 276, 278,

20 - 21

231, 232, 233, 234, 235, 236, 237, 238, 272, 274, 276, 278,

22 - 23

121, 122, 123, 124, 125, 126, 127, 128, 141, 142, 143, 144, 145,  
146, 147, 148, 151, 152, 153, 154, 155, 156, 157, 158, 162, 164,  
166, 168, 173, 174,

24

357, 358, 366, 368,

25

525, 526, 529, 530,

26 - 27

515, 516, 519, 520,

28

255, 256, 257, 258, 268, 283, 284,

29 - 31

## Funktionskontrolle, Functional check, Contrôle du fonctionnement

Modellart / model type / Type de modèle

Seite / Side / Page

32 - 33

Montagezeit ca. --- Min.  
Assembly time / Temps de montage

LM  
29000 33



Datum  
18.04.24

Version  
4.3

Kürzel  
HR

Seite  
2/37

## Demontage, Disassembly, Démontage

Modellart / model type / Type de modèle

Seite / Side / Page

532,

34 - 35

283, 284

36 - 37

- Bei nicht vorschriftsgemäßer und/oder fachgerechter Montage sowie unsachgemäßer Nutzung wird bei Personen- oder Sachschaden keinerlei Haftung übernommen!
- Wir empfehlen die Montage nur durch fachkundiges Personal.
- Die Montageanleitung und demontierte Bauteile sollten aufbewahrt werden.
- Bei veränderter Zusammenstellung kann sich die Montagezeit verändern.
- Am Aufstellort muss für eine geeignete Unterlage gesorgt werden, damit bei der Montage der Bodenbelag nicht beschädigt wird.
- Achten Sie bei der Montage darauf, dass Sie das Bezugsmaterial des Möbels nicht beschädigen.
- No liability can be assumed for personal injury or material damage in the event of incorrect and/or unprofessional assembly or improper use.
- We recommend that the assembly only be carried out by competent personnel.
- The assembly instructions and disassembled components should be kept for future reference.
- The assembly time may differ with a different configuration.
- A suitable underlay must be provided at the installation site so that the floor covering is not damaged during installation.
- During assembly, make sure that you do not damage the cover material of the furniture.
- Aucune responsabilité n'est assumée pour les dommages corporels ou matériels éventuels en cas de montage non conforme aux instructions et/ou inapproprié ainsi qu'en cas d'utilisation abusive.
- Nous recommandons de faire réaliser le montage par du personnel qualifié.
- Le manuel de montage et les pièces démontées doivent être conservés.
- Le temps de montage peut varier en cas d'assemblage différent.
- Merci de placer une protection de sol adaptée afin de ne pas endommager le sol pendant le montage.
- Faire attention de ne pas endommager le revêtement du meuble pendant le montage.

Montagezeit ca. --- Min.  
Assembly time / Temps de montage

LM  
29000 33



Datum	Version	Kürzel	Seite
18.04.24	4.3	HR	3/37

## Auspacken, Unpacking, Déballage



- Verpackung mit einem nicht spitzen Gegenstand öffnen z.B. Folienschneider
- Open packaging with a device that is not pointed or sharp, e.g. a foil cutter
- Ouvrir l'emballage à l'aide d'un outil non-pointu (p.e. un découpe plastique)



Montagematerial, Assembly material, Matériel de montage



- In dem Zubehörkarton befinden sich FüÙe, Kufen und das Montagematerial je nach ihrer Zusammenstellung.
- Feet, runners and the assembly material can be found in the box of accessories depending on the configuration.
- Ce carton d'accessoires contient les pieds, les patins et le matériel de montage correspondant à la configuration du meuble.



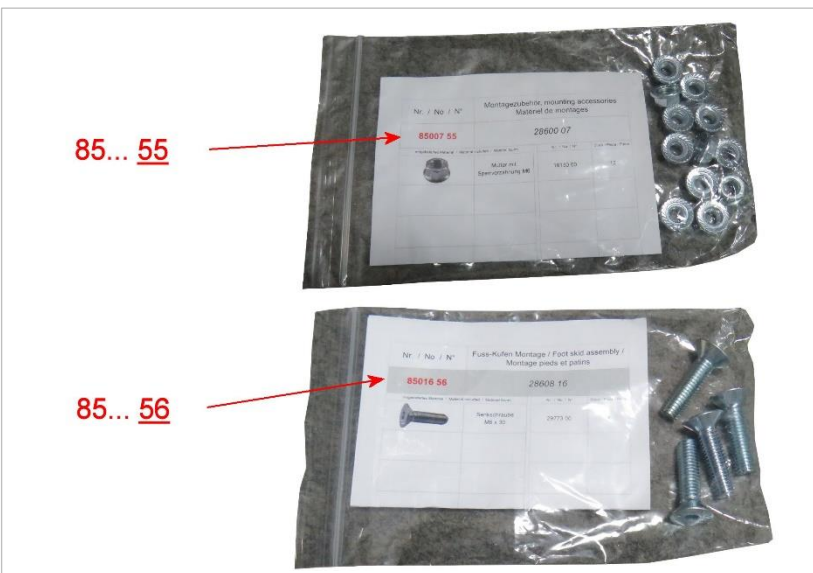

- Je nach Zusammenstellung ihrer Garnitur verändert sich das Montagematerial des Beipack Kartons.
- Die Fuss-Kufen Montageanleitung befindet sich in diesem Karton.
- The assembly material in the accessories box differs depending on the configuration of your furniture.
- The assembly instructions for the feet-runners can be found in this box.
- Le matériel de montage présent dans le carton d'accessoires varie en fonction de la configuration du meuble.
- La notice de montage des patins/pieds se trouve dans ce carton.



- Schrauben für die Montage der Elemente sind mit der Nummer **85...55** gekennzeichnet.
- Schrauben für die Fuss-Kufen Montage sind mit der Nummer **85...56** gekennzeichnet.
- Screws to assemble the elements are marked with the number **85...55**.
- Screws to assemble the feet-runners are marked with the number **85...56**.
- Les vis servant au montage des éléments sont identifiées par le numéro **85...55**.
- Les vis servant au montage des patins/pieds sont identifiées par le numéro **85...56**.

## Montage, Assembly, Montage,

mitgeliefertes Material / Material included / Matériel fourni		Größe / Size / Taille	Nr. / No / N°	Montagezubehör, mounting accessories Matériel de montages
	Senkschraube	M8 x 20	13637 00	85027 55
	Stützkufe		14024 00	





- Auf der Laschen Seite die Stützkufe mit den Senkschrauben montieren.
- Fit the support runner with the countersunk screws on the lug side.
- Monter le patin de support du côté des languettes avec les vis à tête fraisée.



- Wenn vorhanden, Stecker verbinden
- Connect the plug, where present
- Le cas échéant, connecter la fiche



## Montage, Assembly, Montage,

mitgeliefertes Material / Material included / Matériel fourni		Größe / Size / Taille	Nr. / No / N°	Montagezubehör, mounting accessories Matériel de montages
	Senkschraube	M8 x 20	13637 00	85027 55
	Stützkufe		14024 00	



- Auf der Laschen Seite die Stützkufe mit den Senkschrauben montieren.
- Fit the support runner with the countersunk screws on the lug side.
- Monter le patin de support du côté des languettes avec les vis à tête fraisée.



- Stützfuß eindrehen
- Screw in the support foot
- Visser le pied de support

**Montagezeit ca. 10 Min.**  
 Assembly time / Temps de montage

**LM**  
**29000 33**



Datum	Version	Kürzel	Seite
18.04.24	4.3	HR	7/37



# Montage Stützkufe / Assembly of support runner / Montage du patin de support

## Einsitzig Stützkufe / One-seater support runner / Patin de support – une place

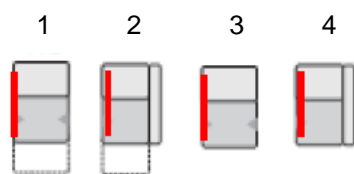

Modellart / model type / Type de modèle	
1	111, 112, 113, 114,
2	122, 124, 126, 128,
3	311, 312, 313, 314,
4	322, 324, 326, 328,
Seite / Side / Page	
6	

## Zweisitzig Stützkufe / Two-seater support runner / Patin de support - deux places

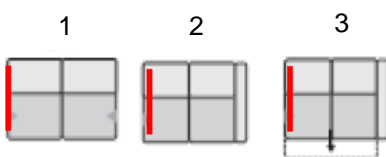

Modellart / model type / Type de modèle	
1	316, 317, 318, 319,
2	352, 354, 356, 358,
3	252, 254, 256, 258,
Seite / Side / Page	
6	

## Zweisitzig 2 Teile / Two-seater 2 parts / Deux places en 2 parties

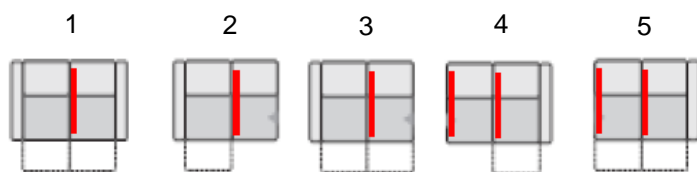

Modellart / model type / Type de modèle	
1	162, 164, 166, 168,
2	141, 143, 145, 147,
3	151, 153, 155, 157,
4	142, 144, 146, 148,
5	152, 154, 156, 158,
Seite / Side / Page	
6	

## Recamiere, Bett, / Recamier, bed / Méridienne, lit

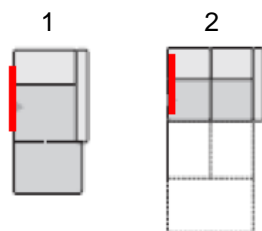

Modellart / model type / Type de modèle	
1	516, 520, 526, 530,
2	232, 234, 236, 238,
Seite / Side / Page	
6	

## Eckteile, / Corner parts, / Angles,

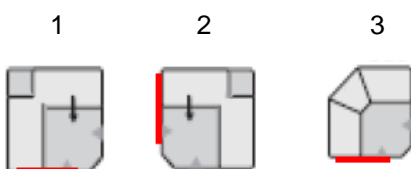

Modellart / model type / Type de modèle	
1	531, 532, 534, 535,
2	536,
3	539, 540,
Seite / Side / Page	
7	

Montagezeit ca. --- Min.  
Assembly time / Temps de montage

LM  
29000 33



Datum	Version	Kürzel	Seite
18.04.24	4.3	HR	8/37



## Integrierte Eckteile / Integrated corner parts / Angles intégrés

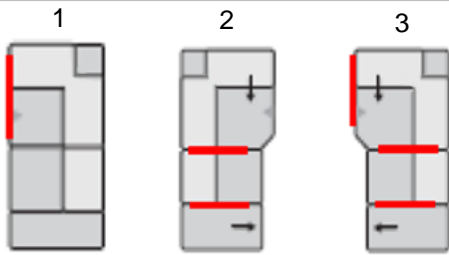

Modellart / model type / Type de modèle	
1	562, 564,
2	581, 583, 585, 587,
3	582, 584, 586, 588,
	Seite / Side / Page
	6 - 7

## Offener Abschluss / Open end element / Extrémité ouverte



Modellart / model type / Type de modèle	
1	543, 545, 547,
2	544, 546, 548,
3	553, 555, 557,
4	554, 556, 558,
	Seite / Side / Page
	11

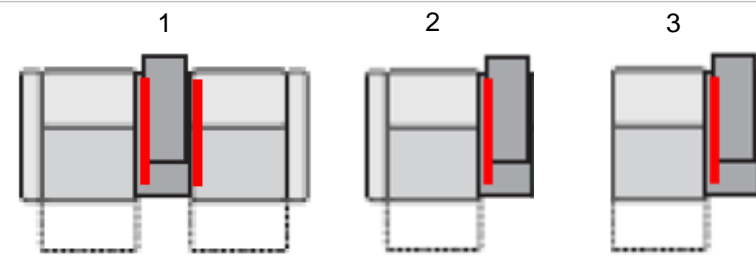

Modellart / model type / Type de modèle	
1	173, 174,
2	135, 136,
3	108
	Seite / Side / Page
	6



## Montage Stützfuß / Assembly of the support foot / Montage du pied de support

## Eckteile / Corner parts / Angles

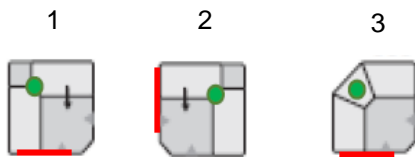

Modellart / model type / Type de modèle	
1	531, 532, 534, 535, 581, 583, 585, 587,
2	536, 582, 584, 586, 588,
3	539, 540,
	Seite / Side / Page
	7

## Integrierte Eckteile / Integrated corner parts / Angles intégrés

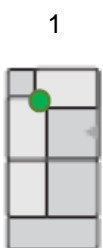

Modellart / model type / Type de modèle	
1	561, 562, 563, 564,
	Seite / Side / Page
	7

Montagezeit ca. --- Min.  
Assembly time / Temps de montage

LM  
29000 33



Datum	Version	Kürzel	Seite
18.04.24	4.3	HR	9/37



**Montage, Assembly, Montage,**

mitgeliefertes Material / Material included / Matériel fourni		Größe / Size / Taille	Nr. / No / N°	Montagezubehör, mounting accessories Matériel de montages
	Gewindesttiff	M8 x 70	29724 00	85020 55
	Sechskantmutter	M8	17623 00	
	Unterlegscheibe	8,4 x 25	29342 00	



- Winkelgleiter entfernen.
- Remove the angled slide.
- Retirer le patin d'angle.



<b>Montagezeit ca. 10 Min.</b> Assembly time / Temps de montage	<b>LM</b> 29000 33	  	Datum	Version	Kürzel	Seite
			18.04.24	4.3	HR	10/37

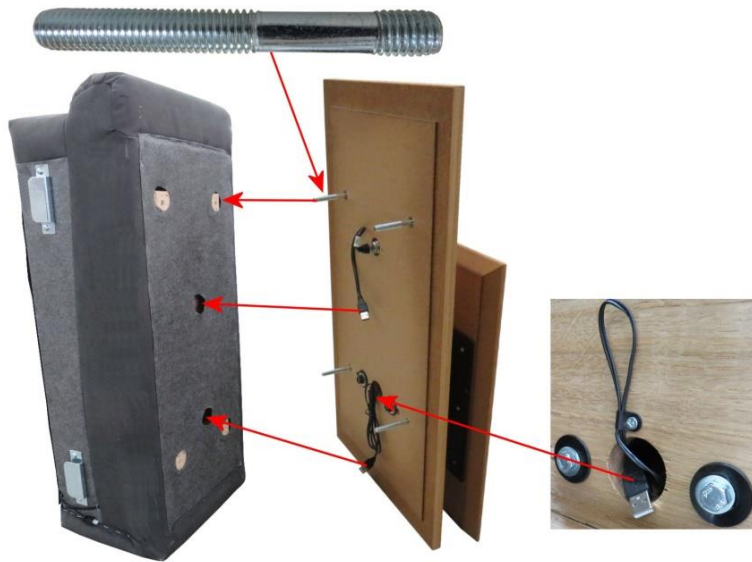

- Gewindestifte mit dem kurzen Gewinde in die Platte eindrehen.
- Nessel am Klettband öffnen.
- Gewindestifte und Kabel in die vorgesehenen Bohrungen beim Ablagetisch schieben.
- Screw the short thread of the grub screw into the table surface.
- Open the Velcro fastener on the calico flap.
- Push the grub screws and cables into the designated drilled holes in the table.
- Visser les tiges filetées avec le filetage court dans la plaque.
- Ouvrir la toile au niveau de la bande Velcro.
- Introduire les tiges filetées et câbles dans les perçages de la tablette prévus à cet effet.

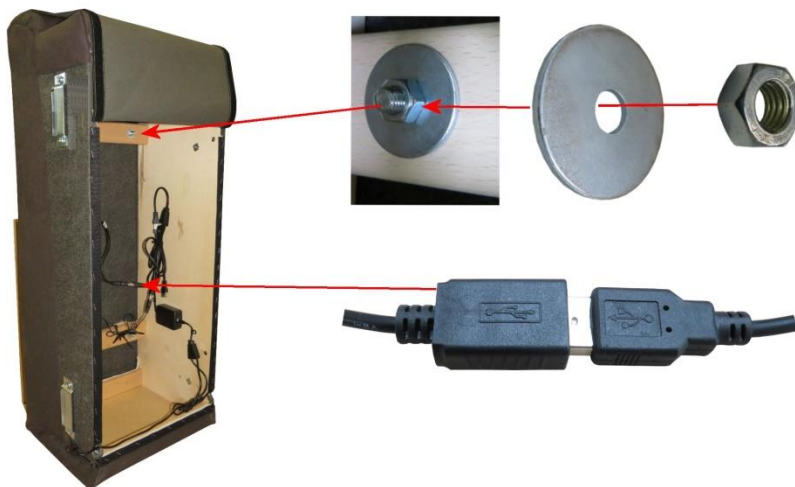

- Jeden Gewindestift mit Unterlegscheibe und Mutter montieren und festziehen.
- Alle vorhandenen Stecker verbinden.
- Nessel am Klettband schließen.
- Fit each grub screw with a washer and tighten.
- Connect all of the plugs, where present.
- Close the Velcro fastener on the calico flap.
- Monter et serrer chaque tige filetée à bloc avec une rondelle et un écrou.
- Connecter toutes les fiches fournies.
- Fermer la toile au niveau de la bande Velcro.

## Montage, Assembly, Montage,

mitgeliefertes Material / Material included / Matériel fourni		Größe / Size / Taille	Nr. / No / N°	Montagezubehör, mounting accessories Matériel de montages
	Gewindestift	M8 x 80	29725 00	85023 55
	Sechskantschraube	M8 x 80	13656 00	
	Unterlegscheibe	8,4 x 25	29342 00	

mitgeliefertes Material / Material included / Matériel fourni		Größe / Size / Taille	Nr. / No / N°	Montagezubehör, mounting accessories Matériel de montages
	Sechskantmutter	M8	17623 00	85023 55
	Senkkopfschraube	M6 x 25	23981 00	85009 55



- Rückenverbinder vom Rücken entfernen.
- Sitz- und Rückenelement auf die Seite stellen und Rücken ganz anstellen.
- Remove back connector from back
- Place the seat and back elements on their side and position the back up against the side element.
- Retirez le connecteur arrière de l'arrière
- Placer l'élément d'assise et de dossier sur le côté et relever entièrement le dossier.

Montagezeit ca. 20 Min.  
Assembly time / Temps de montage

LM  
29000 33



Datum	Version	Kürzel	Seite
18.04.24	4.3	HR	12/37



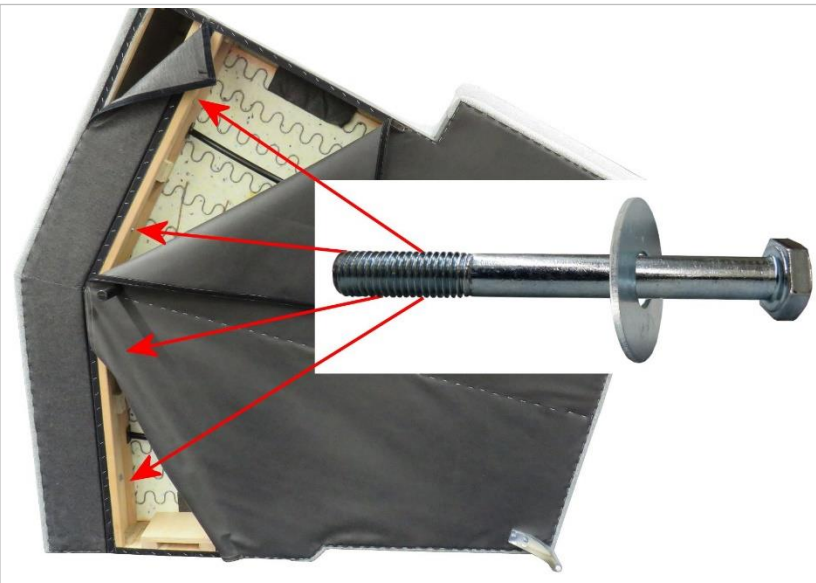

- Nessel am Klettband öffnen.
- Rücken mit Sechskantschrauben mit Unterlegscheiben ansetzen.
- Open the Velcro fastener on the calico flap.
- Insert the hex head screws with washers into the backrest.
- Ouvrir la toile au niveau de la bande Velcro.
- Installer le dossier avec des vis à six pans et des rondelles.



- Rückenverbinder mit 5 Stück Senkkopfschrauben montieren.
- Fit the back connector with 5 countersunk screws.
- Monter le connecteur du dossier avec 5 vis à tête fraisée.

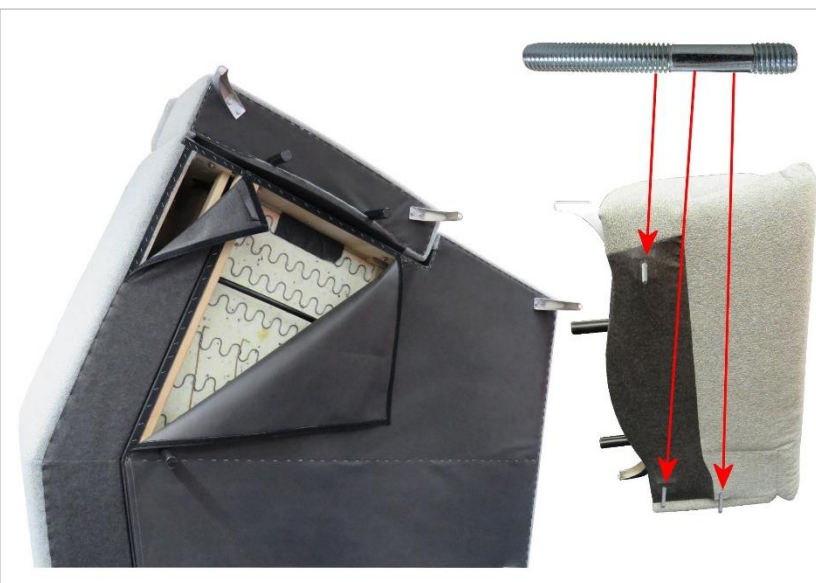

- Gewindestifte mit dem kurzen Gewinde in das Seitenteil eindrehen.
- Gewindestifte bei den vorgesehenen Bohrungen am Korpus einschieben.
- Screw the short thread of the grub screw into the side part.
- Insert grub screws into the designated drilled holes in the body.
- Visser les tiges filetées avec le filetage court dans la partie latérale.
- Insérer les tiges filetées dans les perçages prévus sur le corps.



- Seitenteil mit Unterlegscheibe und Muttern verschrauben.
- Nessel am Klettband schließen.
- Bolt the side part together with washers and nuts.
- Close the Velcro fastener on the calico flap.
- Visser la partie latérale avec des rondelles et des écrous.
- Fermer la toile au niveau de la bande Velcro.



- Jetzt die FüÙe oder Kufen nach beiliegender Anleitung montieren.
- Now fit the feet or runners according to the enclosed instructions.
- Monter à présent les pieds ou les patins selon le manuel fourni.



- Rückenverbinder auf der zweiten Seite mit 5 Stück Senkkopfschrauben montieren.
- Fit the back connector to the second element with 5 countersunk screws.
- Monter le connecteur du dossier du deuxième côté avec 5 vis à tête fraisée.

Montagezeit ca. 15 Min.  
Assembly time / Temps de montage

LM  
29000 33





Datum	Version	Kürzel	Seite
18.04.24	4.3	HR	14/37



**Montage, Assembly, Montage,**

mitgeliefertes Material / Material included / Matériel fourni		Größe / Size / Taille	Nr. / No / N°	Montagezubehör, mounting accessories Matériel de montages
	Gewindestift	M8 x 50	29726 00	85030 55
	Senkschraube	M8 x 16	17565 00	
	Hülsenmutter	M8	29719 00	

mitgeliefertes Material / Material included / Matériel fourni		Größe / Size / Taille	Nr. / No / N°	Montagezubehör, mounting accessories Matériel de montages
	Unterlegscheibe	40 x 13	27281 00	85030 55
	Unterlegscheibe Gekappt	40 x 13	27281 01	
	Stützkufe		14024 00	



- Deckel von Anbauhocker öffnen.
- Stützkufe außen mit M8x16 und innen mit siehe nächstes Bild verschrauben.
- Open the lid of the footstool end section.
- Bolt the support runner on the outside with M8x16. For the inside, see next image.
- Ouvrir le couvercle du pouf d'extrémité.
- Visser le patin de support à l'extérieur avec des vis M8x16 et à l'intérieur, voir la photo suivante





- Innen Hülse und Unterlegscheibe mit der äußeren Schraube verbinden.
- Beim Beschlag die gekappte Unterlegscheibe verwenden.
- Connect the inner sleeve and washer with the outer screw.
- Use the capped washer for the fittings
- Raccorder la douille intérieure et la rondelle avec la vis extérieure.
- Utiliser la rondelle coupée pour la garniture.

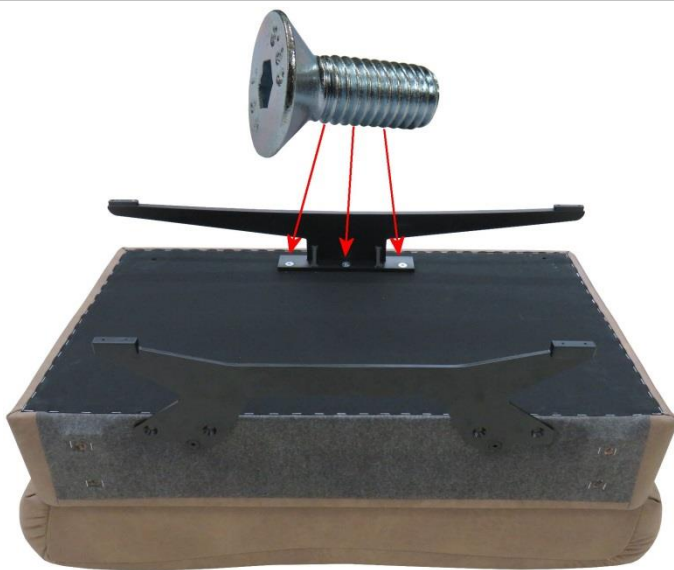

- Siehe Fußmontage
- See assembly of the foot
- Voir le montage des pieds



- Winkelgleiter entfernen.
- Stützkufe nach Anleitung auf Seite 6 montieren.
- Remove the angled slide.
- Fit the support runner according to the instructions on page 6.
- Retirer le patin d'angle.
- Monter le patin de support selon les instructions de la page 6.

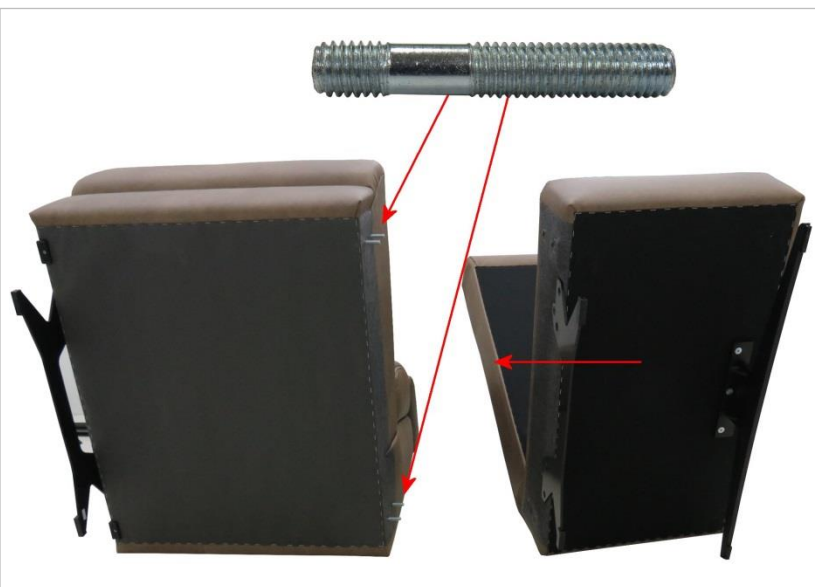

- Gewindestifte mit der kurzen Seite in die Einschlagmutter eindrehen.
- Anbauhocker mit den vorgesehenen Bohrungen über die Gewindestifte schieben.
- Screw the short side of the grub screw into the drive-in nut.
- Align the designated holes drilled in the footstool end section over the grub screws.
- Visser les tiges filetées avec le côté court dans l'écrou à enfoncer.
- Faire glisser le pouf d'extrémité sur les tiges filetées en utilisant les perçages prévus à cet effet.

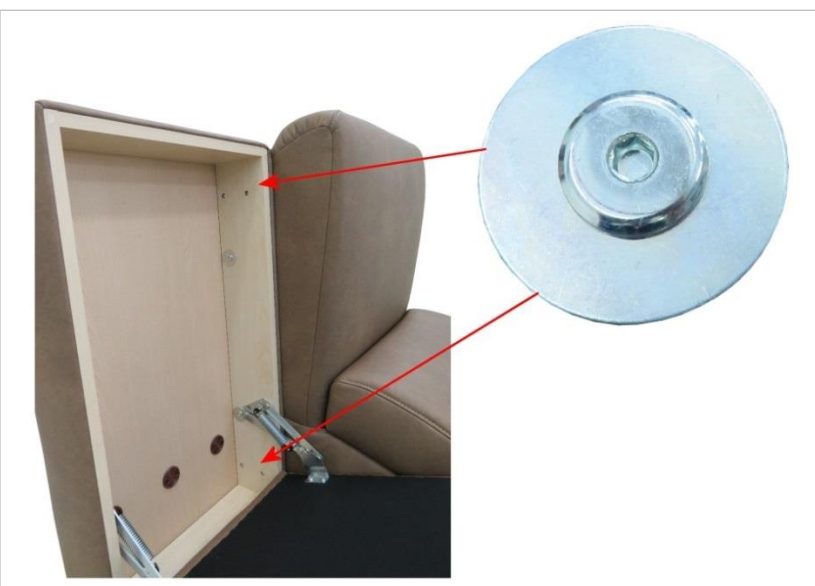

- Unterlegscheibe und Hülsenmutter in die Bohrungen des Anbauhockers stecken und mit Inbusschlüssel festziehen.
- Insert the washers and sleeve nuts into the holes drilled in the footstool end section and tighten with an Allen key.
- Placer la rondelle et l'écrou douille dans les perçages du pouf d'extrémité, puis serrer avec la clé Allen.



## Montage, Assembly, Montage,

mitgeliefertes Material / Material included / Matériel fourni		Größe / Size / Taille	Nr. / No / N°	Montagezubehör, mounting accessories Matériel de montages
	Sechskantmutter	M8	17623 00	85020 55
	Unterlegscheibe	8,4 x 2	29342 00	
	Gewindestift	M8 x 70	29724 00	

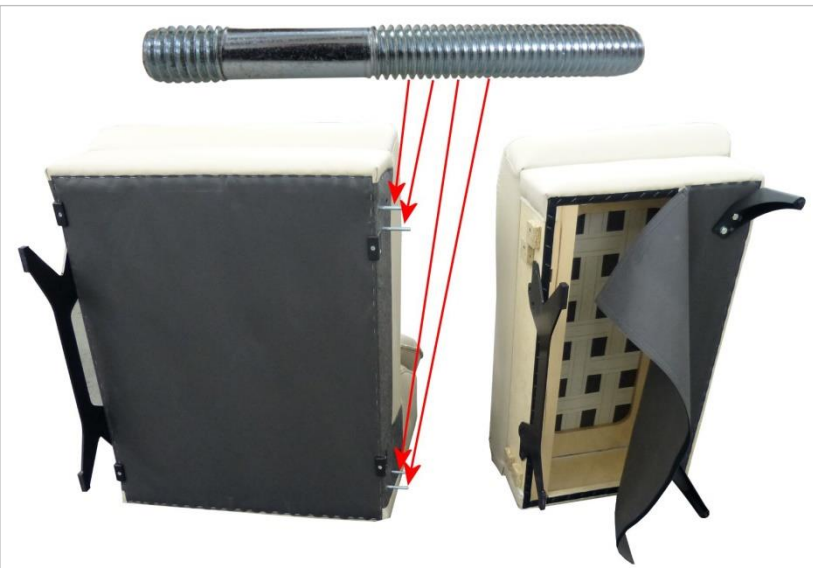

- Nessel am Klettband öffnen.
- Gewindestifte bei den vorgesehenen Bohrungen am Korpus ansetzen.
- Open the Velcro fastener on the calico flap.
- Insert grub screws into the designated drilled holes in the body.
- Ouvrir la toile au niveau de la bande Velcro.
- Insérer les tiges filetées dans les perçages prévus sur le corps.

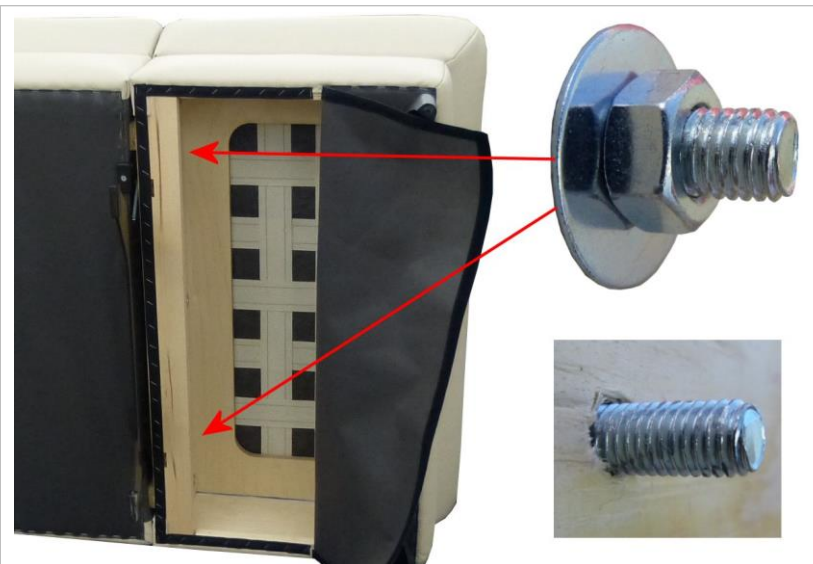

- Anbauhocker mit Unterlegscheibe und Muttern verschrauben.
- Nessel am Klettband schließen.
- Bolt end stool together with washers and nuts.
- Close the Velcro fastener on the calico flap.
- Visser le pouf d'extrémité avec des rondelles et des écrous.
- Fermer la toile au niveau de la bande Velcro.

Montagezeit ca. 10 Min.  
Assembly time / Temps de montage

LM  
29000 33



Datum	Version	Kürzel	Seite
18.04.24	4.3	HR	18/37



**Montage, Assembly, Montage,**

mitgeliefertes Material / Material included / Matériel fourni	
	Senkschraube

Größe / Size / Taille	Nr. / No / N°	Montagezubehör, mounting accessories Matériel de montages
M6 x 55	17568 00	85029 55



**ACHTUNG!**  
Kabelbinder müssen entfernt werden! Funktionsbeschlag steht unter Spannung, es besteht Verletzungsgefahr!

**ATTENTION!**  
Cable ties must be removed! Functional fitting is under tension, there is a risk of injury!

**ATTENTION!**  
Les serre-câbles doivent être retirés! La ferrure fonctionnelle est sous tension, il y a risque de blessure!

- Kabelbinder und Transportschutz entfernen.
- **Achtung: Untergestell steht beim aufklappen durch einer Feder unter Spannung.**
- Remove the cable ties and transport protection.
- **Attention: When unfolding, the base frame is under tension because of the spring.**
- Retirer le serre-câble et la protection de transport.
- **Attention: le socle est tendu par un ressort au moment d'être rabattu.**



- Sitzfläche drehen.
- Turn the seat.
- Tourner l'assise.

mitgeliefertes Material / Material included / Matériel fourni



Senkschraube

Größe / Size / Taille

M8 x 70

Nr. / No / N°

20251 00

Montagezubehör,  
mounting accessories  
Matériel de montages

85028 55



- Transportschutz entfernen.
- Remove transport protection.
- Supprimer la protection de transport.



- Führungsdübel am Seitenteil in die Bohrung am Bettgestell einführen.
- Insert the plugs on the side part into the drilled hole in the bed frame.
- Introduire la cheville de guidage sur la partie latérale dans le perçage sur le cadre du lit.

Montagezeit ca. 25 Min.  
Assembly time / Temps de montage

LM  
29000 33



Datum  
18.04.24

Version  
4.3

Kürzel  
HR

Seite  
20/37





- Seitenteil mit den Senkschrauben M8x70 montieren.
- Fuß-Kufen Montage siehe beiliegende Anleitung
- Mount the side part with the M8x70 countersunk screws.
- Please refer to the enclosed instructions when mounting the feet-runners
- Monter la partie latérale avec les vis à tête fraisée M8x70.
- Montage du pied/patin. Voir les instructions ci-jointes



- Pappe Transportschutz beim Lattenrost unterlegen.
- **Senkschraube M8x70 unten oben in das Seitenteil montieren.**
- Place the cardboard transport protection beneath the slatted frame.
- **Fit a M8x70 countersunk screw into the top and bottom of the side part.**
- Placer une protection de transport en carton sous le caillebotis.
- **Placer une vis à tête fraisée M8x70 en bas et en haut dans la partie latérale.**



Montagezeit ca. 25 Min.  
Assembly time / Temps de montage

LM  
29000 33



Datum	Version	Kürzel	Seite
18.04.24	4.3	HR	21/37

mitgeliefertes Material / Material included / Matériel fourni



Senkschraube

Größe / Size / Taille

Nr. / No / N°

Montagezubehör,  
mounting accessories  
Matériel de montages

M6 x 55

17568 00

85029 55

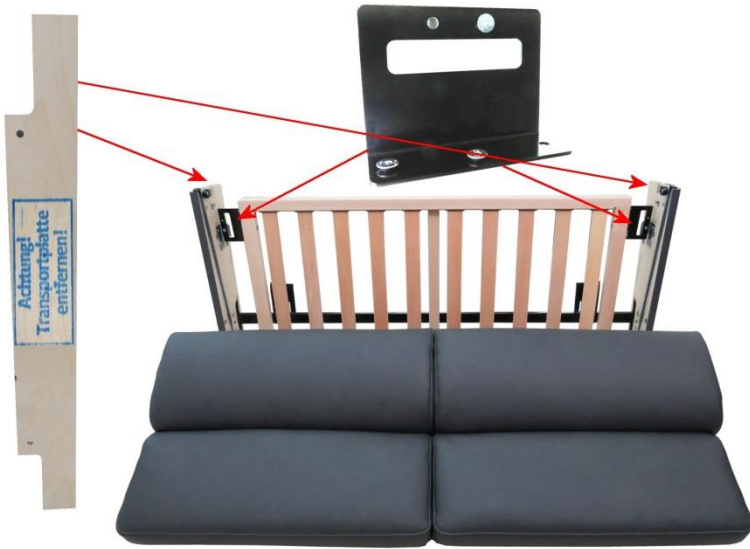

- Transportschutz entfernen.
- Remove transport protection.
- Supprimer la protection de transport.



- Lattenrost mit Kopfteil ganz rausziehen.
- Pull slatted frame with headrest completely out.
- Sortir complètement le caillebotis avec l'appuie-tête.

Montagezeit ca. 25 Min.  
Assembly time / Temps de montage

LM  
29000 33



Datum

Version

Kürzel

Seite

18.04.24

4.3

HR

22/37

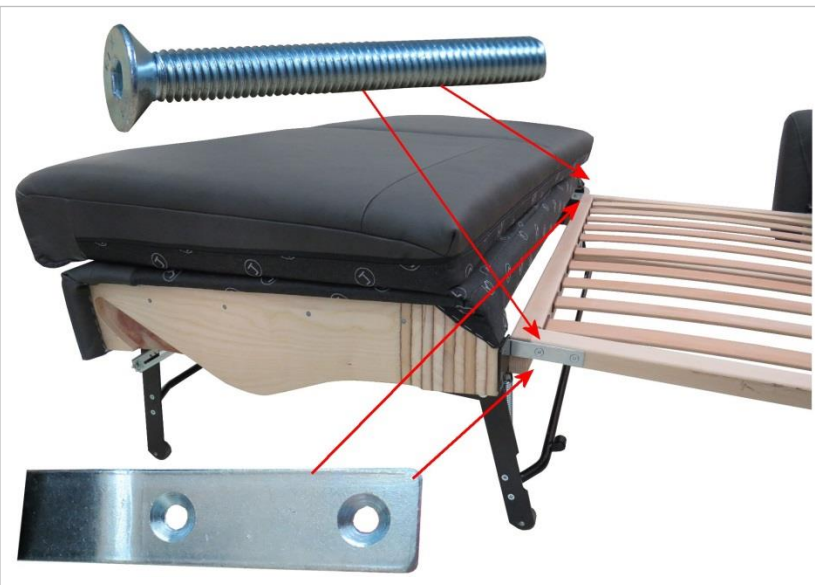

- Metalllasche in der Führungsschiene ganz nach hinten ziehen und mit dem Lattenrost verschrauben.
- Pull the metal lug in the guide rail as far back as it will go and screw to the slatted frame.
- Tirer la languette métallique du rail de guidage à fond vers l'arrière et la visser au caillebotis.



- Rücken anheben und Sitzfläche einschieben.
- Lift up the back and slide in the seat.
- Relever le dossier et pousser l'assise.



- Rücken entriegeln und in Grundposition bringen.
- Unlock the back and move to its initial position.
- Déverrouiller le dossier et le placer en position initiale.

## Montage, Assembly, Montage

mitgeliefertes Material / Material included / Matériel fourni

Größe / Size / Taille

Nr. / No / N°

Stück / Piece / Pièce



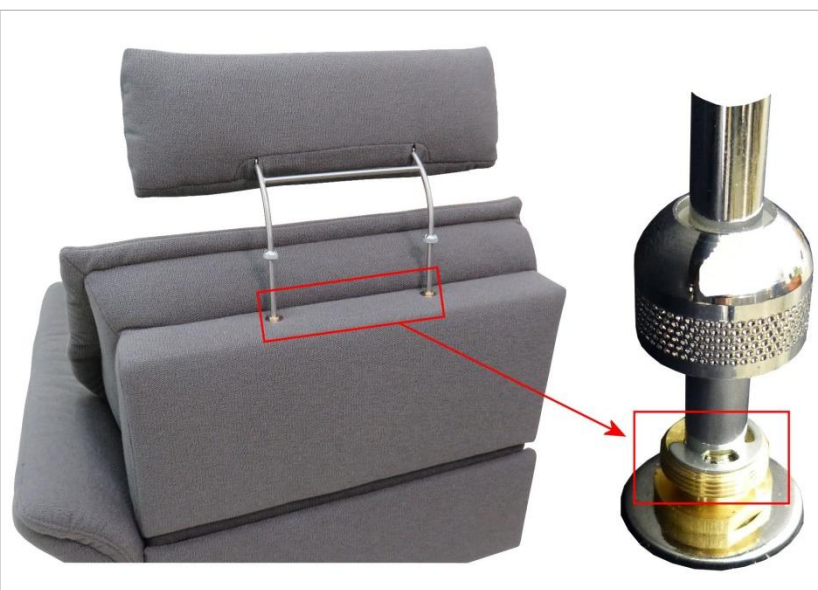

- Kopfstütze in den Rücken stecken bis der Sicherheitsclip am Spannkopf anliegt.
- Push the headrest into the back until the safety clip rests against the clamping head.
- Enficher l'appuie-tête dans le dossier jusqu'à ce que l'attache de sécurité repose sur la tête de serrage.



- Mutter ganz nach unten schieben und am Spannkopf mit dem Gewinde festdrehen.
- Push the nut right down and tighten with the thread on the clamping head.
- Insérer l'écrou jusqu'en bas et tourner la tête de serrage avec le filetage.

Montagezeit ca. 5 Min.

Assembly time / Temps de montage

LM  
29000 33



Datum

18.04.24

Version

4.3

Kürzel

HR

Seite

24/37



## Montage, Assembly, Montage,

mitgeliefertes Material / Material included / Matériel fourni		Größe / Size / Taille	Nr. / No / N°	Montagezubehör, mounting accessories Matériel de montages
	Sechskantmutter	M8	17623 00	85020 55
	Unterlegscheibe	8,4 x 2	29342 00	
	Gewindestift	M8 x 70	29724 00	

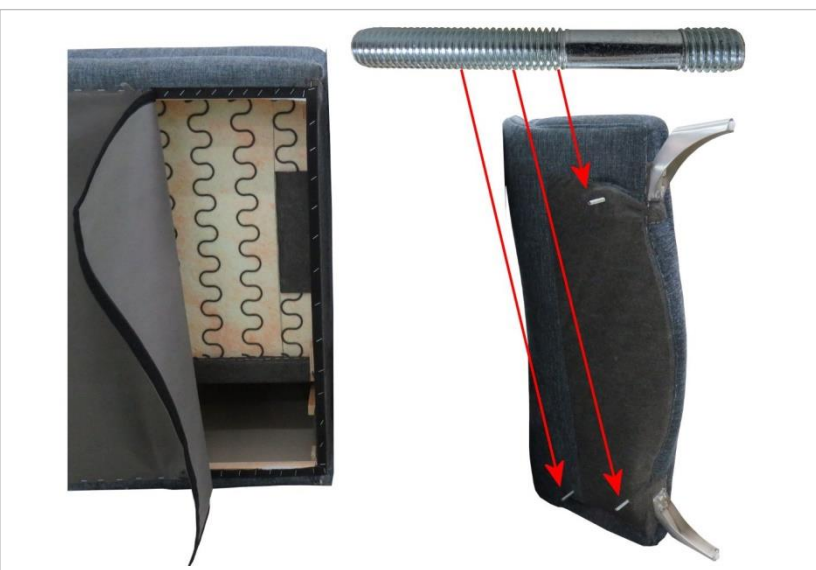

- Nessel am Korpus öffnen.
- Gewindestifte mit dem kurzen Gewinde in das Seitenteil eindrehen.
- Gewindestifte bei den vorgesehenen Bohrungen am Korpus einschieben.
- Open the calico flap on the body.
- Screw the short thread of the grub screw into the side part.
- Insert grub screws into the designated drilled holes in the body.
- Ouvrir la toile au niveau du corps.
- Visser les tiges filetées avec le filetage court dans la partie latérale.
- Insérer les tiges filetées dans les perçages prévus sur le corps

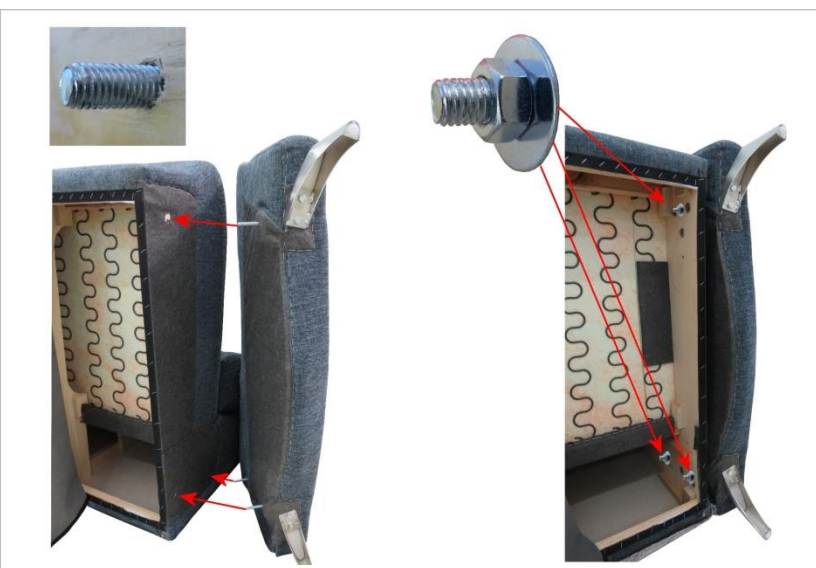

- Seitenteil mit Unterlegscheibe und Muttern verschrauben.
- Bolt the side part together with washers and nuts.
- Visser la partie latérale avec des rondelles et des écrous.





Montagezeit ca. 15 Min.  
Assembly time / Temps de montage

LM  
29000 33



Datum	Version	Kürzel	Seite
18.04.24	4.3	HR	25/37

## Montage, Assembly, Montage

mitgeliefertes Material / Material included / Matériel fourni		Größe / Size / Taille	Nr. / No / N°	Montagezubehör, mounting accessories Matériel de montages
	Sechskantschraube	M8 x 80	13656 00	85023 55
	Unterlegscheibe	8,4 x 25	29342 00	
	Sechskantmutter	M8	17623 00	
mitgeliefertes Material / Material included / Matériel fourni		Größe / Size / Taille	Nr. / No / N°	Montagezubehör, mounting accessories Matériel de montages
	Gewindestift	M8 x 80	29725 00	85023 55



- Korpus auf die Seite drehen und Nessel beim Klettverschluss öffnen.
- Turn the Recliner onto its side and open the Velcro fastener on the calico fla.
- Faire tourner la méridienne sur le côté et ouvrir la toile au niveau de la fermeture auto-agrippante.

Montagezeit ca. 15 Min.  
Assembly time / Temps de montage

LM  
29000 33



Datum	Version	Kürzel	Seite
18.04.24	4.3	HR	26/37



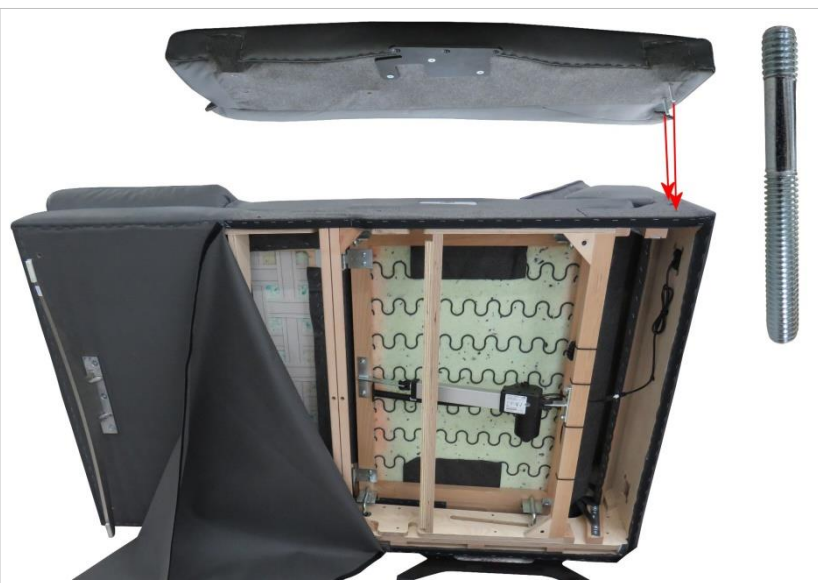

- Gewindestifte mit dem kurzen Gewinde bei den hinteren Einschlagmuttern am Seitenteil eindrehen.
- Seitenteil mit Korpus verbinden.
- Screw in the threaded pins with the short thread at the rear drive-in nuts on the side panel.
- Connect the side part to the body.
- Vissez les tiges filetées avec le filetage court sur les écrous d'entraînement arrière sur le panneau latéral.
- Raccorder la partie latérale au corps.

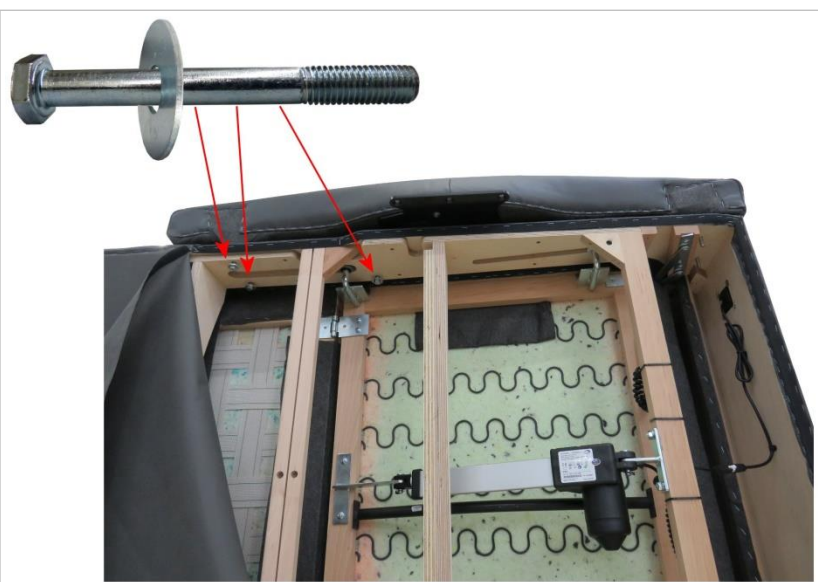

- Sechskantschraube mit Unterlegscheibe montieren.
- Fit the hex head bolts with washers.
- Monter la vis à six pans avec la rondelle.

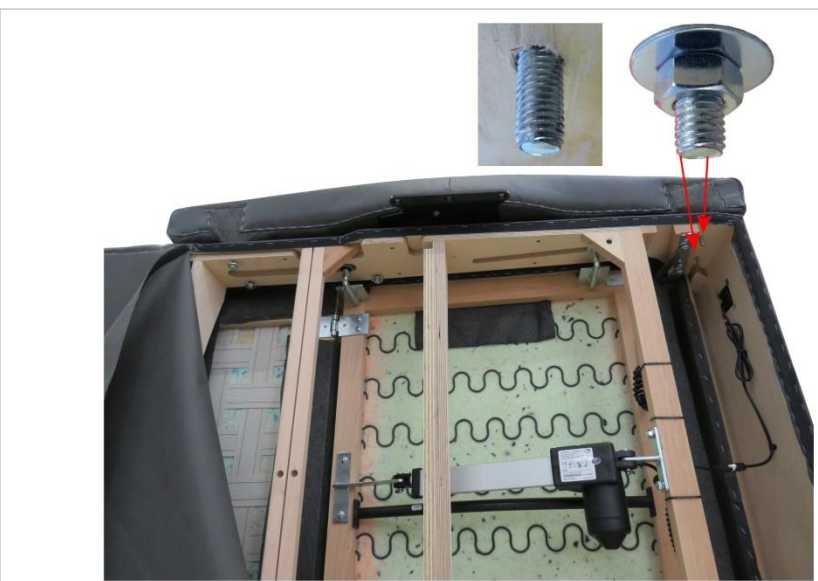

- Gewindestifte mit Unterlegscheibe und Mutter montieren.
- Nessel schließen und Recamiere auf die Füße stellen
- Fit the grub screws with washers and nuts.
- Close the calico flap and place the Recamier on its feet
- Monter la tige filetée avec la rondelle et l'écrou.
- Fermer la toile et placer la méridienne sur ses pieds

## Montage, Assembly, Montage,

mitgeliefertes Material / Material included / Matériel fourni		Größe / Size / Taille	Nr. / No / N°	Montagezubehör, mounting accessories Matériel de montages
	Gewindestift	M8 x 70	29724 00	85020 55
	Sechskantmutter	M8	17623 00	
	Unterlegscheibe	8,4 x 25	29342 00	



- Nessel am Korpus öffnen.
- Gewindestifte mit dem kurzen Gewinde in das Seitenteil eindrehen.
- Gewindestifte bei den vorgesehenen Bohrungen am Korpus einschieben.
- Open the calico flap on the body.
- Screw the short thread of the grub screw into the side part.
- Insert grub screws into the designated drilled holes in the body.
- Ouvrir la toile au niveau du corps.
- Visser les tiges filetées avec le filetage court dans la partie latérale.
- Insérer les tiges filetées dans les perçages prévus sur le corps

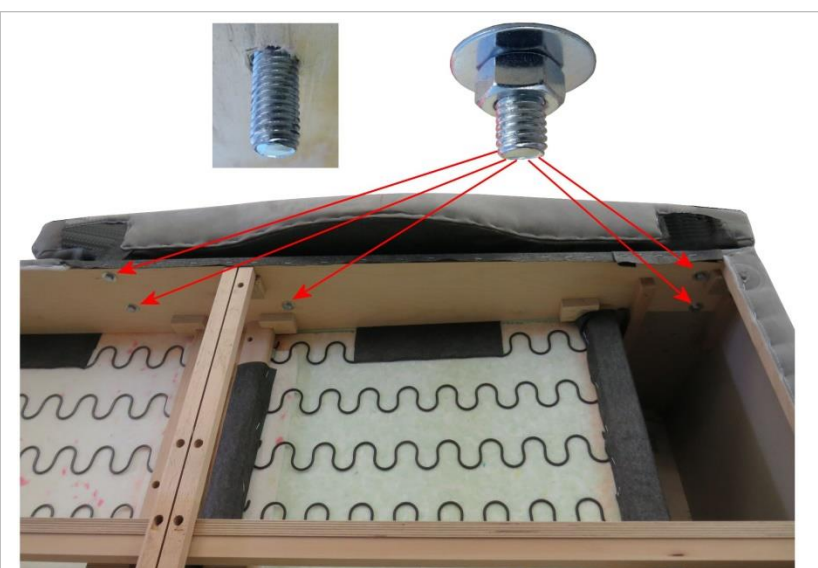

- Seitenteil mit Unterlegscheibe und Muttern verschrauben.
- Nessel schließen und Recamiere auf die Füße stellen
- Bolt the side part together with washers and nuts.
- Close the calico flap and place the Recamier on its feet
- Visser la partie latérale avec des rondelles et des écrous.
- Fermer la toile et placer la méridienne sur ses pieds



Montagezeit ca. 10 Min.  
Assembly time / Temps de montage

LM  
29000 33



Datum	Version	Kürzel	Seite
18.04.24	4.3	HR	28/37

**Montage, Assembly, Montage**

mitgeliefertes Material / Material included / Matériel fourni		Größe / Size / Taille	Nr. / No / N°	Montagezubehör, mounting accessories Matériel de montages
	Senkschraube	M8 x 70	20251 00	85031 55
	Unterlegscheibe	8,4 x 25	29342 00	
	Sechskantmutter	M8	17623 00	

mitgeliefertes Material / Material included / Matériel fourni		Größe / Size / Taille	Nr. / No / N°	Montagezubehör, mounting accessories Matériel de montages
	Gewindesttiff	M8 x 70	29724 00	85031 55
	Senkschraube	M8 x 70	20251 00	



- Netzverbindung herstellen und Vorziehfunktion ausfahren.
- Netzverbindung wieder entfernen.
- Connect to the mains power supply and extend the pull-out function.
- Disconnect from the mains power supply.
- Brancher le raccordement secteur et sortir la fonction d'avancement.
- Débrancher de nouveau le raccordement secteur.

**Montagezeit ca. 25 Min.**  
Assembly time / Temps de montage

**LM**  
**29000 33**

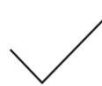

Datum	Version	Kürzel	Seite
18.04.24	4.3	HR	29/37



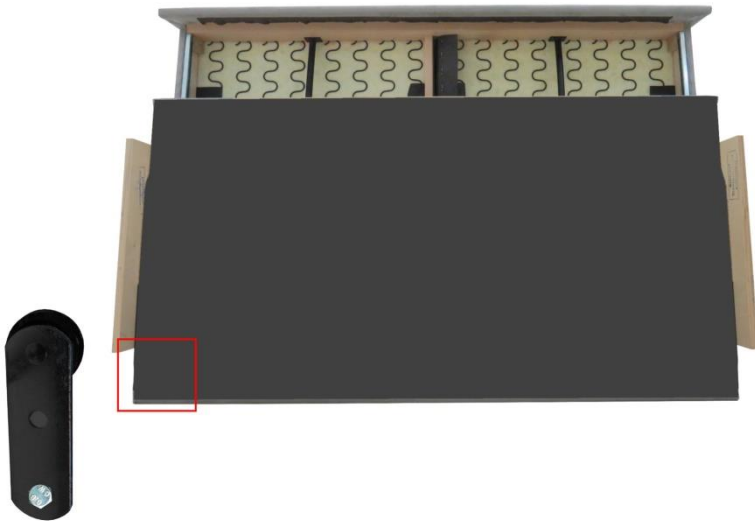

- Korpus auf den Rücken drehen und Nessel beim Klettverschluss öffnen.
- Kippschutz entfernen und nach der Montage wieder befestigen.
- Place the body onto its back and open the Velcro fastener on the calico flap.
- Remove the anti-tipper and reattach it after assembly.
- Faire tourner le corps sur le dossier et ouvrir la toile au niveau de la fermeture auto-agrippante.
- Ôter le protège-renversement et le remettre après montage

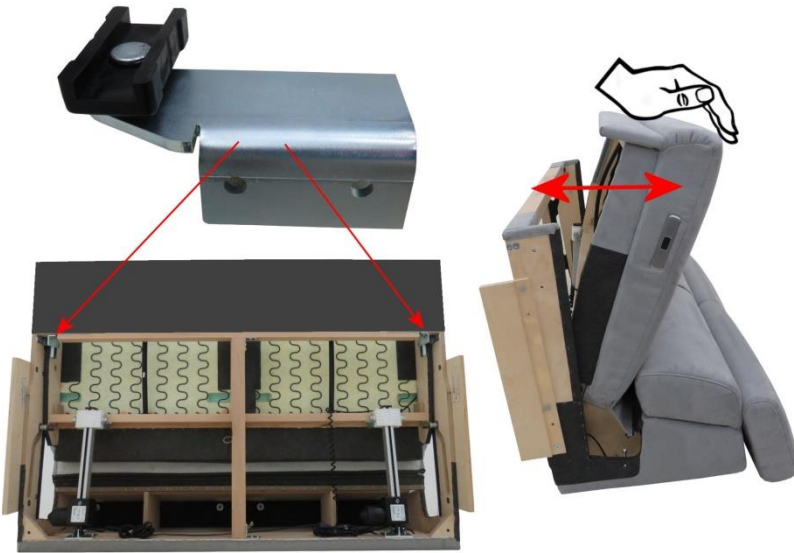

- Führungswinkel auf beiden Seiten entfernen.
- **Achtung: Sitzfläche gegen schnelles abfallen stützen.**
- Remove the guide bracket on both sides.
- **Attention: support the seat to stop it falling down too quickly.**
- Retirer l'angle de guidage des deux côtés.
- **Attention : Soutenir l'assise pour éviter qu'elle ne tombe rapidement.**

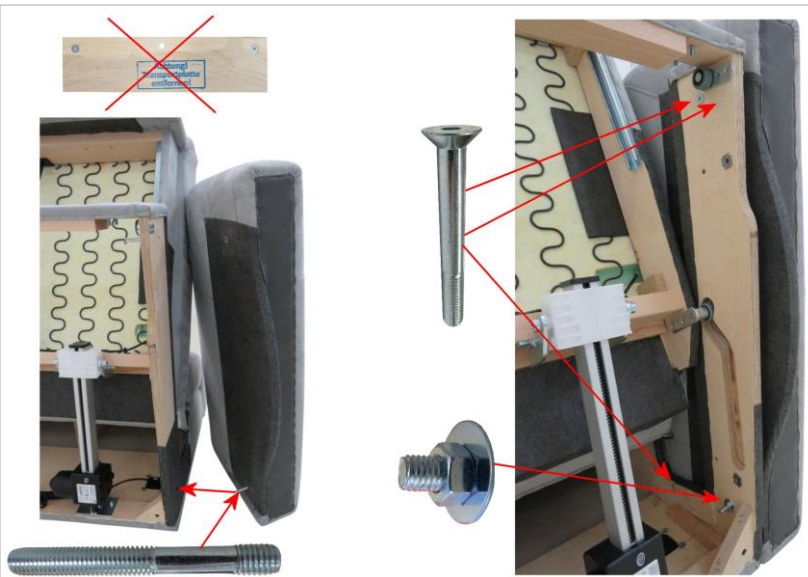

- Transportschutz entfernen.
- Gewindestift beim Seitenteil mit dem kurzen Gewinde hinten unten eindrehen.
- Seitenteil mit den Schrauben, Mutter und Unterlegscheibe montieren.
- Remove the transport protection.
- Screw the short thread of the grub screw into the rear of the side part at the bottom.
- Mount the side part with the screws, nuts and washers.
- Retirer la protection de transport.
- Visser la tige filetée avec le filetage court en bas à l'arrière sur la partie latérale.
- Monter la partie latérale avec les vis, les écrous et la rondelle.



- Sitzfläche an das Holzgestell drücken.
- Beide Winkel wieder so montieren wie sie demontiert worden sind.
- Press the seat onto the wooden frame.
- Mount the two brackets in their original positions.
- Appuyer l'assise contre le support en bois.
- Remonter les deux équerres dans l'ordre du démontage.

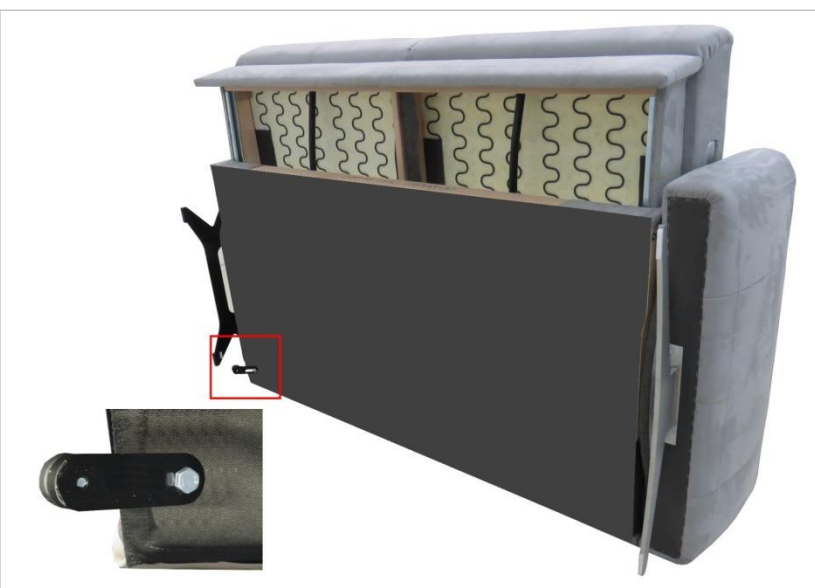

- Je nach Bestellung: FüÙe, Kufe, Stützkufe und Kippschutz montieren. (Siehe weitere Anleitungen)
- Nessel am Klettverschluss schließen.
- Depending on the order: mount feet, runners, supporting runners and anti-tipper. (Please refer to further instructions)
- Close the Velcro fastener on the calico flap.
- Selon la commande: Monter les pieds, le patin, le patin d'appui et le protège-renversement (Voir les autres instructions)
- Fermer la toile au niveau de la fermeture auto-agrippante.



## Funktionskontrolle, Functional check, Contrôle du fonctionnement



- Transportplatte und Transportsicherungen bei allen Elementen entfernen.
- Remove transport plates and transport protectors from all elements.
- Retirer la plaque et les sécurités de transport de tous les éléments.

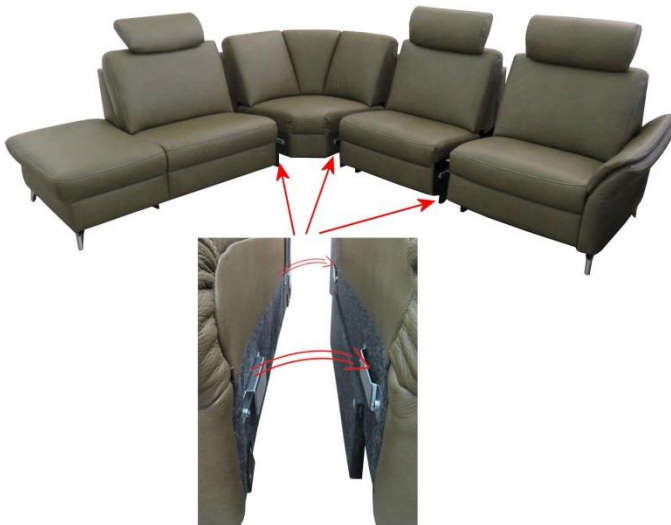

- Bei allen Elementen Haken in Laschen von Rechts nach Links einhängen.
- Hang the hook in the lugs on all elements from right to left.
- Pour tous les éléments, accrocher les crochets (gauche) dans les languettes de droite.



- Alle Stützfüße nachstellen bis Bodenkontakt vorhanden ist, bzw. Spaltmaße anpassen.
- Adjust all support feet until they make contact with the floor and/or adjust the clearances.
- Régler tous les pieds de support jusqu'à ce qu'ils soient en contact avec le sol ou ajuster l'écartement.





- Netzverbindung herstellen
- Alle vorhandenen, Stecker verbinden.
- Connect to the mains
- Connect all of the plugs, where present.
- Brancher le raccordement secteur
- Connecter toutes les fiches fournies.

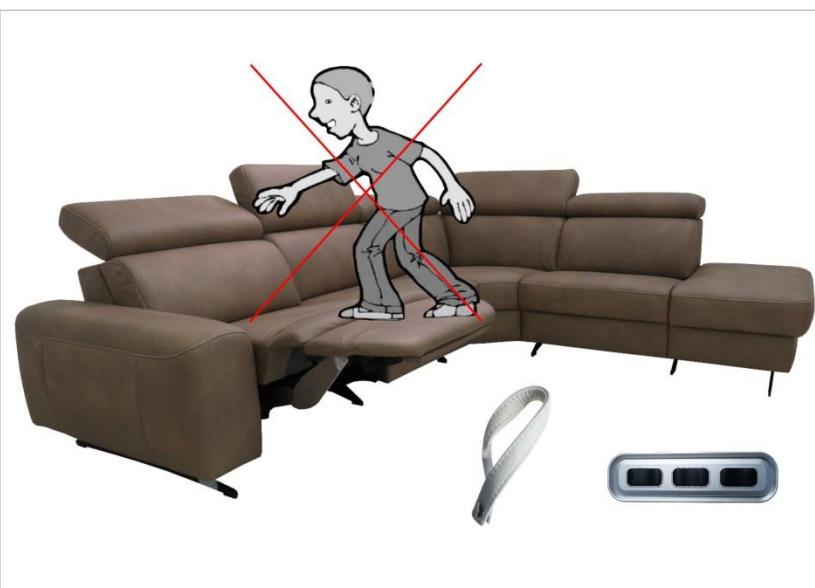

- Funktionskontrolle bei allen Elementen ohne Belastung durchführen
- Überlastungen auf der Beinauflage führen zu Beschädigungen
- Please conduct the function control for all elements without load
- Overloading on the footrest will result in damages
- Tester tous les éléments sans pression
- Une surcharge sur le repose-pieds peut entraîner des dommages

## Demontage, Disassembly, Demontage



- Element aufstellen
- Set up the unit
- Placer l'élément



- Eckteil auf den Rücken drehen
- Place corner unit on its back
- Tourner la partie d'angle sur le dos

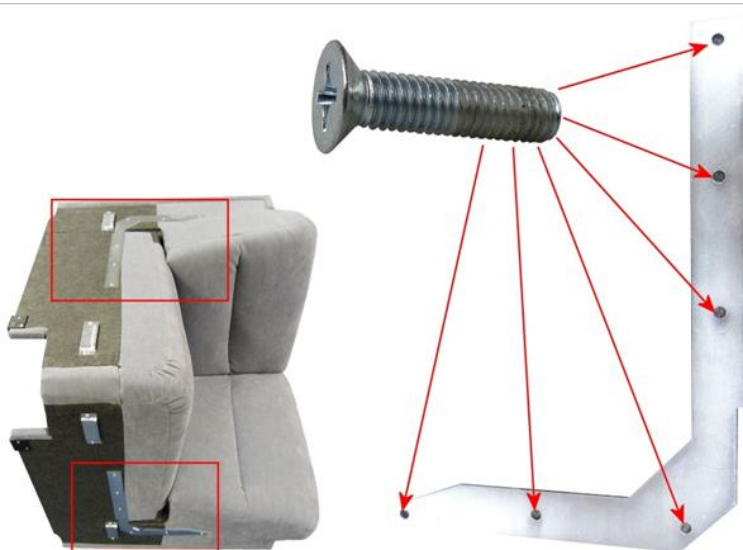

- Auf beiden Seiten die 6 Stück M8x25mm Senkkopfschrauben lösen.
- Release the six M8x25mm countersunk screws on both sides.
- Desserrer les 6 unités de vis à tête fraisée M8x25 mm des deux côtés.

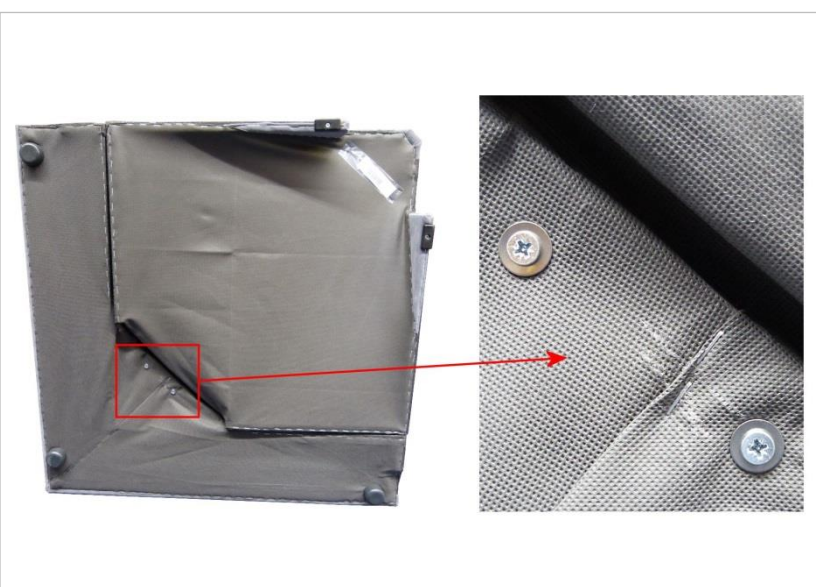

- Auf der Unterseite die 5x45mm Spax mit Unterlegscheiben lösen.
- Release the 5x45mm Spax screws and washers on the underside.
- Desserrer les vis Spax 5x45 mm avec les rondelles sur la partie inférieure.



- Die Montage erfolgt in umgekehrter Reihenfolge.
- Assemble in reverse order.
- Le montage est effectué dans l'ordre inverse.

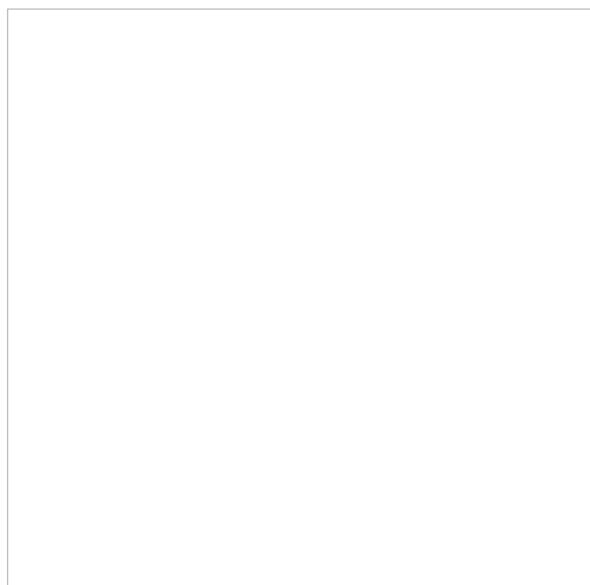
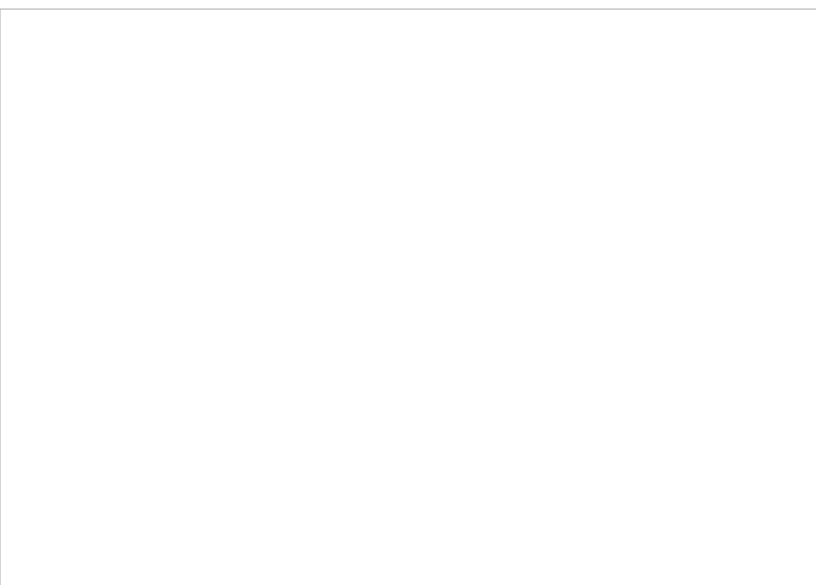

## Demontage, Disassembly, Demontage



- Demontage Rücken
- Netzverbindung herstellen
- Dismantling the back
- Connect to the mains
- Démontage de l'arrière
- Brancher le raccordement secteur



- Reißverschluss öffnen
- Element auf den Rücken legen.
- Nessel mit Klettband öffnen.
- Reißverschluss öffnen
- Turn the element onto its back. Positionner
- Open the Velcro fastener of the calico flap.
- Reißverschluss öffnen
- Positionner l'élément sur le dossier.
- Ouvrir la toile avec la bande Velcro.

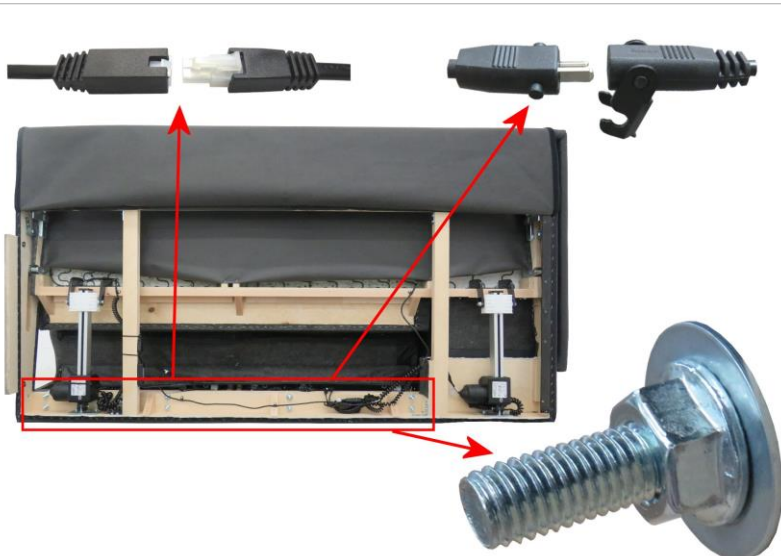

- Stecker lösen
- Alle Muttern lösen.
- Disconnect plug
- Loosen all nuts.
- Débrancher la fiche
- Desserrer tous les écrous.





- Nessel mit Klettband schießen.
- Close the Velcro fastener of the calico flap.
- Fermer la toile avec la bande Velcro.

- Die Montage erfolgt in umgekehrter Reihenfolge.
- Assemble in reverse order.
- Le montage est effectué dans l'ordre inverse.

